

IACS

INTERNATIONAL ASSOCIATION OF CLASSIFICATION SOCIETIES LTD.
PERMANENT SECRETARIAT: 4 MATTHEW PARKER STREET
WESTMINSTER, LONDON, SW1H 9NP, UNITED KINGDOM
TEL: +44(0)207 976 0660
INTERNET: permsec@iacs.org.uk Web Site: www.iacs.org.uk

Jan 2025

History Files (HF) and Technical Background (TB) documents for Recommendations

Res. No.	Title	Current Rev.	HF/TB?
Rec 1	Portable electrical equipment	Deleted (Dec 1996)	No
Rec 2	Type of hatch cover required if a lower deck is designated as the freeboard deck	Deleted (Nov 2010)	No
Rec 3		Deleted	No
Rec 4		Deleted (1996) <i>Superseded by UR W24</i>	No
Rec 5	Method of corrosion fatigue testing	Deleted (1997)	No
Rec 6	Selection of electrical equipment based on location condition	Deleted (May 2004)	No
Rec 7	Guide for the use of hull structural steels for prolonged exposure to low service temperatures	Deleted (Jul 2003)	No
Rec 8	Provisions for the carriage of heated oils and oils with a flash point above 60°C up to 100°C on dry cargo ships	Deleted (Nov 2011)	No
Rec 9	Guidelines for installation of cargo oil discharge monitoring and control system on board oil tankers	Deleted (Sept 2005)	No
Rec 10	Anchoring, Mooring and Towing Equipment	Rev.5 June 2023	HF
Rec 11	Materials Selection Guideline for Mobile Offshore Drilling Units	Rev.3 Oct 2019	HF
Rec 12	Guidelines for Surface Finish of Hot Rolled Steel Plates and Wide Flats	Deleted (July 2018)	No
Rec 13	Standards for Ship Equipment for Mooring at Single Point Moorings	Rev.3 July 2020	HF
Rec 14	Hatch cover securing and tightness	Corr.1 Oct 2005	No
Rec 15	Care and survey of hatch covers of dry cargo ships – Guidance to owners	Rev.3 Aug 2013	HF

Res. No.	Title	Current Rev.	HF/TB?
Rec 16	Heading information for emergency steering position	Rev.1 Dec 2003	No
Rec 17	Guidelines for the Acceptance of Manufacturer's Quality Assurance Systems for Welding Consumables	Rev.1 Mar 2020	HF
Rec 18	Fire Prevention in Machinery Spaces of Ships in Service – Guidance to Owners	Rev.2 Feb 2021	HF
Rec 19		Deleted (1996)	No
Rec 20	Non-destructive testing of ship hull steel welds	Deleted (Dec 2019)	No
Rec 21	Guidelines on approval procedure for onboard loading computers	Deleted (Mar 2021)	HF
Rec 22	Recommendations for the classification of areas where flammable gas or vapour risks may arise to permit the proper selection of electrical equipment	Deleted (May 2001)	No
Rec 23	Earthed distribution systems on tankers	Deleted (Dec 1996)	No
Rec 24	Intact Stability	Rev.7 Nov 2023	HF
Rec 25	Capacity of cargo tank's venting system	Deleted (Nov 2010)	No
Rec 26	Spare parts for main internal combustion engines of ships for unrestricted service	Rev.2 Nov 2023	HF
Rec 27	List of minimum recommended spare parts for each type of auxiliary internal combustion engine driving electric generators for essential services on board ships for unrestricted service	Rev.2 Feb 2024	HF
Rec 28	List of minimum recommended spare parts for auxiliary steam turbines driving electric generators for essential services of ships for unrestricted service	Rev.2 Feb 2024	HF
Rec 29	List of minimum recommended spare parts for main steam turbines of ships for unrestricted service	Rev.2 Feb 2024	HF
Rec 30	List of minimum recommended spare parts for essential auxiliary machinery of ships for unrestricted service	Rev.2 Feb 2024	HF
Rec 31	Recommended procedure for inclining test	Rev.3 Apr 2023	HF
Rec 32	Guidelines on Welding Procedure Qualification tests for hull construction	Deleted (Jun 2005)	No
Rec 33	Guidelines for the Construction of Pressure Vessel Type Tanks Intended for the Transportation of Anhydrous Ammonia at Ambient Temperatures	Deleted (Mar 2021)	HF
Rec 34	Standard Wave Data	Rev.2 Dec 2022	HF

Res. No.	Title	Current Rev.	HF/TB?
Rec 35	Inspection and Maintenance of Electrical Equipment Installed in Hazardous Areas for Ships Other Than Tankers	Rev.2 Feb 2021	HF
Rec 36	Recommended procedure for the determination of contents of metals and other contaminants in stern tube lubricating oil	Rev.3 Nov 2020	HF
Rec 37	Guidelines for Cast Steel Container Corner Fittings	Deleted (Jul 2003)	No
Rec 38	Guidelines for the Survey of Offshore Mooring Chain Cable in Use	Rev.2 July 2020	HF
Rec 39	Safe Use Of Rafts Or Boats For Survey	Rev.3 Mar 2009	TB
Rec 40	Survey Guidelines – Emergency Towing Arrangements	1995	No
Rec 41	Guidance for Auditors to the ISM Code	Rev.5 Oct 2019	HF
Rec 42	Guidelines for use of remote inspection techniques for surveys	Rev.2 June 2016	HF
Rec 43	Care and Survey of Equipment required by MARPOL 73/78, Annex I – Guidance to owners	Deleted (Oct 2010)	No
Rec 44	Survey Guidelines for tanks in which soft coatings have been applied	Corr.1 Dec 2007	No
Rec 45	Guidelines for Container Corner Fittings	Deleted (Dec 2019)	No
Rec 46	Bulk Carriers – Guidance and Information on Dry Cargo Loading and Discharging to Reduce the Likelihood of Over-stressing the Hull Structure	Rev.2 Jan 2020	HF
Rec 47	Shipbuilding and Repair Quality Standard	Rev.9 June 2021	HF
Rec 48	Recommendations on Loading instruments	Rev.1 June 2020	HF
Rec 49	Testing of Protection Devices for Generators and Large Consumers on Board	Rev.1, Corr. 1999	No
Rec 50	Recommendation on Minimum Content of Casualty Data Check Lists	1997	No
Rec 51	Testing of Protection Devices for Generators and Large Consumers on Board	Deleted (Mar 1999) <i>Re-categorised as Rec.49</i>	No
Rec 52	Power Supply to Radio Equipment required by SOLAS Chapter IV, and Electrical/Electronic Navigation Equipment required by SOLAS regulation V/19	Rev.2 Feb 2021	HF
Rec 53	Periodic Survey and Testing of Foam Concentrates, CO2 and Halon Containers	Rev.1 Oct 2023	HF

Res. No.	Title	Current Rev.	HF/TB?
Rec 54	Guidelines for Acceptance, Application and Survey of Semihard Coatings in Ballast Tanks	Rev.1 Oct 2006	No
Rec 55	General Dry Cargo Ships – Guidelines For Surveys, Assessment and Repair of Hull Structure	Rev.1 June 2016	HF
Rec 56	Fatigue Assessment of Ship Structures	Jul 1999	No
Rec 57	Maintenance and Inspection of Electrical Equipment on the Ship	Rev.1 Mar 2016	HF
Rec 58	Fire Protection of Machinery Spaces	Rev.2 Feb 2021	HF
Rec 59	In-service testing of large permanently installed breathing gas containers onboard diving vessels	May 1999	No
Rec 60	Intact stability of tankers during liquid transfer operations	Corr.1 Nov 2022	HF
Rec 61	Recommended Maximum Allowable Rudder Pintle Clearance	Deleted (Apr 2020)	HF
Rec 62	Container Prototype and production certificates	Deleted (Jan 2015)	No
Rec 63	General cargo containers: prototype test procedures and test measurements	Deleted (Jan 2015)	No
Rec 64	Quality Control arrangements at works engaged in series production of containers	Deleted (Jan 2015)	No
Rec 65	Tank containers: prototype test procedures and test measurements	Deleted (Jan 2015)	No
Rec 66	Thermal containers: prototype test procedures and test measurements	Deleted (Jan 2015)	No
Rec 67	Test and Installation of busbar trunking systems	Rev.1 June 2018	HF
Rec 68	Guidelines for non-destructive testing of hull and machinery steel forgings	Rev.1 Apr 2021	HF
Rec 69	Guidelines for non-destructive testing of marine steel casting	Rev.2 Oct 2020	HF
Rec 70	Guidelines on welding procedure qualification tests of aluminium alloys for hull construction and marine structures	Rev.1 Nov 2006	TB
Rec 71	Guide for the development of shipboard technical manuals	Corr.1 Mar 2014	HF
Rec 72	IACS Confined Space Safe Practice	Rev.4 Jan 2025	HF
Rec 73	Type approval procedure for cable trays/protective casings made of plastics materials	Rev.3 Dec 2023	HF
Rec 74	Guide to Managing Maintenance in accordance with the requirements of the ISM Code	Rev.2 Aug 2018	HF
Rec 75	Format for Electronic Exchange of Class and Statutory Data	Corr.1 Oct 2020	HF

Res. No.	Title	Current Rev.	HF/TB?
Rec 76	IACS Guidelines for Surveys, Assessment and Repair of Hull Structure – Bulk Carriers	Corr.1 Sept 2007	No
Rec 77	Guidelines for the Surveyor on how to Control the Thickness Measurement Process	Rev.4 Oct 2017	HF
Rec 78	Safe use of Portable Ladders for Close-up Surveys	Sept 2002	No
Rec 79	Guidance for anchoring equipment in service	Rev.1 July 2014	HF
Rec 80	Containers “in One Door Off” Operation	Deleted (Jan 2013)	HF
Rec 81	Guidance on the ISPS Code for Maritime Security Auditors	May 2003	No
Rec 82	Surveyor’s Glossary, Hull Terms and Hull Survey Terms	Rev.1 Oct 2018	HF
Rec 83	Notes to Annexes to IACS Unified Requirement S1A on Guidance for Loading/Unloading Sequences for Bulk Carriers	Aug 2003	No
Rec 84	Container Ships – Guidelines for Surveys, Assessment and Repair of Hull Structure	Rev.1 Nov 2017	HF
Rec 85	Recommendations on Voyage Data Recorder	Rev.1 Dec 2018	HF
Rec 86	Applicable Standards for UR P4.7 “Requirements for Type Approval of Plastic Pipes”	Rev.2 Mar 2019	HF
Rec 87	Guidelines for Coating Maintenance & Repairs for Ballast Tanks and Combined Cargo/Ballast Tanks on Oil Tankers	Rev.2 May 2015	HF
Rec 88	Periodical hydrostatic tests of air cylinders of safety equipment	Rev.1 Apr 2020	HF
Rec 89	Firms engaged in testing of navigational equipment and systems	Rev.2 June 2020	HF
Rec 90	Ship structure access manual	Rev.2 Nov 2024	HF
Rec 91	Guidelines for Approval / Acceptance of Alternative Means of Access	Rev.3 Apr 2019	HF
Rec 92	IACS Guidelines for ISM Code and ISM Code aligned audits and SMC and ISSC expiration dates alignment	Deleted (Oct 2019)	No
Rec 93	Performance Standards for Universal Automatic Identification Systems (AIS) (SOLAS Reg.V/18.2)	Dec 2006	No
Rec 94	Guideline for application of UR S31 Rev.4	Apr 2007	No
Rec 95	Recommendation for the Application of SOLAS Regulation V/15 – Bridge Design, Equipment Arrangement and Procedures (BDEAP)	Rev.1 Mar 2022	HF

Res. No.	Title	Current Rev.	HF/TB?
Rec 96	Double Hull Oil Tankers – Guidelines for Surveys, Assessment and Repair of Hull Structure	Rev.2 May 2023	HF
Rec 97	Recommendation for UR S11.2.1.3, Rev.5	Jun 2007	No
Rec 98	Duties of Surveyors under Statutory Conventions and Codes	Rev.3 June 2019	HF
Rec 99	Recommendations for the Safety of Cargo Vessels of less than Convention Size	Rev.1 Apr 2013	HF
Rec 100	IACS recommended practice on the time requirement for thoroughly closing sea inlets and discharges below the waterline in case of influx of water	Feb 2008	TB
Rec 101	IACS Model Report for IMO Resolution MSC.215(82) Annex 1 “Test Procedures for Coating Qualification”	Jun 2008	No
Rec 102	IACS Model Report for IMO Resolution MSC.215(82) Annex 1 “Test Procedures for Coating Qualification”, Section 1.7 – Crossover Test	Jun 2008	No
Rec 103	Guidance for the compilation of the IOPP Supplement	Rev.1 July 2020	HF
Rec 104	Qualification scheme for welders of steels	Mar 2009	TB
Rec 105	Qualification scheme for welders of aluminium alloys	Corr.1 Jan 2022	HF
Rec 106	IACS Guideline for Rule Development – Ship Structure	Jul 2009	TB
Rec 107	Guidance for Application of Vertical Contract Audits	Deleted (Sep 2011)	No
Rec 108	Not assigned		
Rec 109	Acceptance criteria for cargo tank filling limits higher than 98% (on ships constructed before 1 July 2016)	Rev.1 May 2017	HF
Rec 110	Guideline for Scope of Damage Stability Verification on new oil tankers, chemical tankers and gas carriers	Rev.2 Mar 2021	HF
Rec 111	Passenger Ships – Guidelines for preparation of Hull Structural Surveys	Rev.1 June 2018	HF
Rec 112	Not assigned		
Rec 113	Expert Parties Engaged in Visual and/or Sampling Checks for Preparation of Inventory of Hazardous Materials	Rev.1 Oct 2012	HF
Rec 114	Recommendation for operational testing, inspection and documentation of emergency shutdown valves for liquefied gas carriers	Rev.1 Dec 2018	HF

Res. No.	Title	Current Rev.	HF/TB?
Rec 115	Not assigned		
Rec 116	Performance Standard for Protective Coatings for Cargo Oil Tanks of Crude Oil Tankers – 5 years field exposure test in accordance with MSC.288 (87)	Deleted (Sep 2023)	HF
Rec 117	Exchange of Statutory Documentation upon Transfer of Class	Rev.2 May 2020	HF
Rec 118	Maritime Labour Convention, 2006: Handling of Seafarer Complaints by Recognized Organizations	Deleted (June 2019)	HF
Rec 119	Uniform application of SOLAS Reg. II-1/3-9 in association with MSC.1/Circ.1331	Rev.1 Apr 2013	HF
Rec 120	Survey of electrical equipment installed in hazardous areas on tankers	June 2015	HF
Rec 121	Uniform application of MARPOL Annex I, Revised Regulation 12	Corr.1 June 2021	HF
Rec 122	Integral Buoyancy Casings in Lifeboats and Rescue Boats	Jan 2012	HF
Rec 123	“Recommendation based on IMO instruments – MSC.1/Circ.1370 “Guidelines for the design, construction and testing of fixed hydrocarbon gas detection systems” and Resolution MSC.292 (87) “Amendments to the FSS Code Chapter 16 Fixed Hydrocarbon Gas Detection Systems””	May 2012	HF
Rec 124	Guidance on the role of the Recognised Security Organisation in relation to the employment of armed guards and the installation of citadels on board ships threatened by piracy in the Indian Ocean	May 2012	HF
Rec 125	Not assigned		
Rec 126	Record of approved GMDSS radio installation	Nov 2015	HF
Rec 127	A guide to risk assessment in ship operations	Rev.1 Nov 2021	HF
Rec 128	Record of approved Ship Safety Equipment	Nov 2015	HF
Rec 129	Guidance on DMLC Part II review, inspection and certification under the Maritime Labour Convention, 2006	Rev.1 June 2019	HF
Rec 130	Procedures for verifying that materials are asbestos free	Rev.1 Sept 2016	HF
Rec 131	Guidelines for application of SOLAS Ch.II-2 Reg. 4.5.7.3.2 for accepting a constant operative inerting systems (COIS) as an alternative to fixed hydrocarbon gas detection equipment in double hull and double-bottom spaces on oil tankers	Rev.1 Nov 2023	HF

Res. No.	Title	Current Rev.	HF/TB?
Rec 132	Human element recommendations for structural design of lighting, ventilation, vibration, noise, access and egress arrangements	Dec 2013	HF
Rec 133	Guidelines for pilot schemes of extended interval between surveys in dry-dock – extended dry-docking (EDD) scheme	Nov 2013	HF
Rec 134	Boat transfers safe practice	Rev.1 Oct 2022	HF
Rec 135	Rooms for emergency fire pumps in cargo ships	June 2014	HF
Rec 136	Guidelines for working at height	June 2014	HF
Rec 137	Recommendation for protection of socket outlets for road freight units	Oct 2014	HF
Rec 138	Recommendation for the FMEA process for diesel engine control systems	Dec 2014	HF
Rec 139	Guidelines on Approval of Hull Steels with Improved Fatigue Properties	Feb 2015	HF
Rec 140	Recommendation for safe precautions during Survey and Testing of Pressurized Systems	Rev.1 Mar 2019	HF
Rec 141	Guidelines for the Assessment of Safety Aspects at Workplace	July 2015	HF
Rec 142	LNG Bunkering Guidelines	June 2016	HF
Rec 143	Recommended procedure for the determination of contents of metals and other contaminants in a closed fresh water system lubricated stern tube	Oct 2015	HF
Rec 144	Inspection of ship's side valves	Feb 2016	HF
Rec 145	Recommendation for the Operation of Shore-Based Emergency Response Services	May 2016	HF
Rec 146	Risk assessment as required by the IGF Code	Aug 2016	HF
Rec 147	Type Approval Certificate of Internal Combustion Engine	Oct 2016	HF
Rec 148	Survey of liquefied gas fuel containment systems	Rev.1 Mar 2020	HF
Rec 149	Guidance for applying the requirements of 15.4.1.2 and 15.4.1.3 of the IGC Code (on ships constructed on or after 1 July 2016)	May 2017	HF
Rec 150	Vapour pockets not in communication with cargo tank vapour / liquid domes on liquefied gas carriers	May 2017	HF
Rec 151	Recommendation for fuel oil treatment systems	Rev.2 Nov 2023	HF

Res. No.	Title	Current Rev.	HF/TB?
Rec 152	Survival crafts launching stations. Guidance for applying the requirements of 11.3.1 of the IGC Code (on ships constructed on or after 1 July 2016)	Apr 2018	HF
Rec 153	Recommended procedures for software maintenance of shipboard equipment and systems	Deleted (Apr 2019)	HF
Rec 154	Recommendation concerning manual / local control capabilities for software dependent machinery systems	Deleted (Apr 2019)	HF
Rec 155	Contingency plan for onboard computer based systems	Deleted (Apr 2019)	HF
Rec 156	Network Architecture	Deleted (Apr 2019)	HF
Rec 157	Data Assurance	Deleted (Apr 2019)	HF
Rec 158	Physical Security of onboard computer based systems	Deleted (Apr 2019)	HF
Rec 159	Network Security of onboard computer based systems	Deleted (Apr 2019)	HF
Rec 160	Vessel System Design	Deleted (Apr 2019)	HF
Rec 161	Inventory List of computer based systems	Deleted (Apr 2019)	HF
Rec 162	Integration	Deleted (Apr 2019)	HF
Rec 163	Remote Update / Access	Deleted (Apr 2019)	HF
Rec 164	Communication and Interfaces	Deleted (Apr 2019)	HF
Rec 165	Recommendation for assessing design instances based on application of alternative methods in the hull structural design of CSR ships	Rev.1 Jan 2022	HF
Rec 166	Recommendation on Cyber Resilience	Corr.2 Apr 2022	HF
Rec 167	Guidelines for the Identification of Vibration Issues and Recommended Remedial Measures on Ships	Corr.2 Apr 2022	HF
Rec 168	Recommendation on transverse extent of timber deck cargoes	New June 2021	HF
Rec 169	Guidelines on Approval of High Manganese Austenitic Steel for Cryogenic Service	New Sep 2021	HF
Rec 170	The term of "heavy load carrier" for the application of EEDI/EEXI and CII	New May 2022	HF
Rec 171	Recommendation on incorporating cyber risk management into Safety Management Systems	New May 2022	HF
Rec 172	EEXI Implementation Guidelines	Rev.1 Apr 2024	HF

Res. No.	Title	Current Rev.	HF/TB?
Rec 173	Guidelines on Numerical Calculations for the purpose of deriving the Vref in the framework of the EEXI Regulation	New Nov 2022	HF
Rec 174	Recommended procedure for the finite element analysis to assess yielding, buckling and fatigue of ICG Code type C tanks	New July 2023	HF
Rec 175	SEEMP/CII Implementation Guidelines	New Apr 2023	HF
Rec 176	Measurement of Underwater Radiated Noise	New Sep 2023	HF
Rec 177	Shipbuilding and Remedial Quality Standard for Machinery Piping Systems	New Dec 2023	HF
Rec 178	Earthing Guidelines for Maritime Industry	New Dec 2023	HF
Rec 179	Recommendation for Valve Regulated Lead Acid (VRLA) Starting Batteries of Emergency Generators	New Dec 2023	HF
Rec 180	Recommendation for conducting commissioning testing of Ballast Water Management Systems	Rev.1 Nov 2024	HF
Rec 181	Measurement of Underwater Radiated Noise from ships	New Nov 2024	HF
Rec 182	Onshore Power Supply	New Dec 2024	HF
Rec 183	Ship Data Quality	New Dec 2024	HF
Rec 184	Guidelines on safety standards for work	New Jan 2025	HF

Recommendation No.10

“Chain Anchoring, Mooring and Towing Equipment”

Summary

In this revision, a new appendix for alternative direct calculation of anchoring equipment is introduced to allow this new methodology of determination of anchoring equipment.

Part A. Revision History

Version no.	Approval date	Implementation date when applicable
Rev.5 (June 2023)	15 June 2023	-
Rev.4 (Sep 2020)	25 September 2020	-
Corr.1 (Dec 2016)	-	-
Rev.3 (Oct 2016)	31 October 2016	-
Rev.2 (June 2005)	June 2005	-
Corr.1 (Dec 2004)	December 2004	-
Rev.1 (Aug 1999)	August 1999	-
New (1982)	1982	-

- **Rev. 5 (June 2023)**

1 Origin of Change:

- Suggestion by IACS member

2 Main Reason for Change:

IACS Member uses different methodology than required by UR A1 for the selection of anchoring equipment for small vessels (cargo ships less than 65 m and non-cargo ships less than 90 m). A new appendix for alternative direct calculation of anchoring equipment is introduced to allow this new methodology of determination of anchoring equipment.

Line Design break force definition is updated to be in line with IMO MSC.1/Circ. 1619 and OCIMF MEG-4

3 List of non-IACS Member classification societies contributing or participating in IACS Working Group:

None

4 History of Decisions Made:

During evaluation of anchoring equipment for small vessels it has been identified that IACS member has different way to select anchoring equipment than required by UR A1.

To avoid any major modification, it has been decided to implement this new selection method as an alternative to the methodology given in UR A1.

Since it is an alternative, it is more appropriate to implement the methodology in an IACS recommendation, recommendation 10 being the more appropriate one.

This alternative is based on force calculation on anchoring lines based on drag forces due to wind and current.

Concerning LDBF definition, alignment with MSC.1/Circ.1619 is needed. Particular case of increase of strength for polyamide (nylon) ropes due to strength loss in wet condition covered by the definition of LDBF. The increase of strength for general synthetic lines partly covered by the WLL factor for direct calculated forces.

In case of selection of lines based on equipment number the safety margin is slightly reduced, as the MBLSD listed for the Equipment numbers is based on the safety margin for steel wire.

5 Other Resolutions Changes:

UR A1 and UR A2

6 Any hinderance to MASS, including any other new technologies:

None

7 Dates:

Original Proposal:	31 March 2021	(Made by IACS Member)
Panel Approval:	25 May 2023	(Ref: PH20005_IHak)
GPG Approval:	15 June 2023	(Ref: 21027_IGi)

• Rev.4 (Sep 2020)

1 Origin for Change:

- Request by non-IACS entity
- Suggestion by IACS member

2 Main Reason for Change:

IACS Member identified typo in the table 4 related to anchoring equipment for ships in unsheltered water with depth up to 120m.

IACS Member identified that in paragraph 1.2.5, where Zcont is larger than the duty pull required by 3.1.2 of UR A3, this Zcont should be applied for the design torque-transmitting components and the calculation of overload capacity in addition to the

application of UR A3.

IACS Member and Industry identified the necessity to clarify the determination of deck cargoes side projected area in paragraphs 2.1 and 2.1.2.

A new appendix for direct mooring analysis is introduced to allow more accurate determination of mooring lines.

Feedback from the industry initiated a new discussion about what draft is to be used for determination of the side projected area A1. This area is used to determine mooring loads for large ships. Revisiting this issue, it became evident that the procedure for calculation of A1 in some cases can result in a significant underestimation of the mooring loads in ballast condition. This is corrected in Rev.4.

IACS Member and Industry identified that Rec.10 requires somewhat excessive number of spring lines which is not proportional to the number of head/stern/breast lines, in some cases smaller size ships are to be fitted with more spring lines than bigger size ships which is unreasonably.

IACS Member identified the necessity to introduce some clarification regarding "MBL*" definition to distinguish its two different purposes. In addition, changes were made to align the text and the term Ship design minimum breaking load (MBL_{SD}) of the recommendation and the related UR's with draft MSC.1/Circ.1175/Rev.1 (refer Annex 2 of SDC 6/13) approved by MSC 101 (refer para 12.9 of MSC 101/24)

3 List of non-IACS Member Classification Societies contributing or participating in IACS Working Group:

None

4 History of Decisions Made:

As a result of Hull Panel evaluation and discussions, the following decisions have been taken:

The identified typo in table 4 related to anchoring equipment for ships in unsheltered water with depth up to 120m has been corrected based on ABS Guide on Deep Water Anchoring For Oil Tankers And Bulk Carriers (DWA) July 2015 Edition.

The UR A3 "Anchor Windlass Design and Testing" has been published. In Rec. No. 10 Rev. 3 (Oct 2016) and HF/TB documents, A3 was referenced but these references were removed in the meantime (Rev. 3 Corrigenda 1 Dec 2016) because of delayed finalization of A3. Now, where A3 is published, these references were added again and the requirements come in addition to the formula in 1.2.5. The determination of the deck cargoes side projected area in paragraphs 2.1 and 2.1.2 have been clarified through the definition of the condition to be considered. The side projected area of deck cargoes should be taken as given by the ship nominal capacity condition.

IACS Member and Industry requested clarification on the reasons for accepting the limitation on the MBL value (130t) of the mooring lines in paragraph 2.1.2.1. The Hull Panel decided to include additional information on the Technical Background

without changing the UR text which has been considered clear for its purpose.

The Hull Panel clarified that the calculation of the side projected area A1 shall be performed considering the ballast draft removing the possibility of underestimation for the calculation of mooring loads. In addition, the updated text gives some flexibility for designer/owner to adopt the summer load water line in the calculation of the area A1 for ships having small variation in the draft, like e.g. passenger or RO/RO vessels. This has been decided to avoid undesired impact since UR A2 Rev.4 already introduced a significant increase in the design mooring loads.

The requirement 2.1.2.2 resulting in unreasonably excessive number of spring lines has been amended accordingly.

The designation of "MBL*" have been kept to its original purpose, ship design minimum breaking load of the mooring lines intended to be supplied for adjustment of the "environmental condition", in 2.1.2.1 also corresponding to the modified acceptable wind speed, v_w^* , and v_w^* referenced in UR A2. The definitions utilized in paragraph 2.1.2.2, ship design minimum breaking load required as a result of adjustment of "number of lines" have been modified from "MBL*" to "MBL**" and "n*" to "n**".

For detailed information regarding the different modifications introduced in this revision please refer to the TB section (Annex 2).

5 Other Resolutions Changes:

UR A1 & UR A2

6 Any hinderance to MASS, including any other new technologies:

None

7 Dates:

Original Proposal: 28 September 2017
Panel Approval: 27 August 2020 (Ref: 12106_PHI)
GPG Approval: 25 September 2020 (Ref: 12106_IGzd)

• Corr.1 (Dec 2016)

.1 Origin for Change:

Other (Editorial correction identified by Hull Panel)

.2 Main Reason for Change:

Editorial correction identified by Hull Panel.

.3 List of non-IACS Member Classification Societies contributing through the TC Forum and/or participating in IACS Working Group:

None

.4 History of Decisions Made

References to UR A3 are removed in the recommendation as the same is not yet published. The reference to A3 was also removed in the TB document (Attachment 1 to Annex 1) Clause 1.25.

.5 Other Resolutions Changes

None

.6 Dates:

Original Proposal: 07 November 2016 by Hull Panel
Panel Approval: 09 December 2016 (Ref: PH7011_IHcg).
GPG Approval: N.A.

- **Rev.3 (Oct 2016)**

.1 Origin for Change:

- Request by non-IACS entity
- Suggestion by IACS member

.2 Main Reason for Change:

Due to concerns raised by the industry in view of an increasing number of incidents like anchor losses, IACS decided to review and update Recommendation No. 10 and Unified Requirement A1 "Anchoring Equipment". Operational practices being adopted by many owners, in particular, anchoring in unsheltered waters have been considered for the review of the existing criteria for anchoring to reflect current practice.

Furthermore, due to recurrent incidents during mooring and towing, IACS also decided to review and update Recommendation No. 10 and Unified Requirement A2 "Shipboard fittings and supporting hull structures associated with towing and mooring on conventional ships". Extensive investigations indicated that the minimum recommended number and strength of mooring lines, in particular, for larger ships is insufficient.

.3 List of non-IACS Member Classification Societies contributing through the TC Forum and/or participating in IACS Working Group:

None

.4 History of Decisions Made:

GPG approved the initial Form A for the review of UR A1, UR A2, and Rec. No. 10 on 6 November 2009 (9633_IGc) and a revised Form A on 8 November 2010 (10035_IGg). The task was extended to allow for more extensive investigations and the associated Form A was approved by GPG on 23 August 2012 (12106_IGd).

The final draft revision of Recommendation No. 10 and the associated technical background document were approved by Hull Panel on 6 January 2016.

.5 Other Resolutions Changes:

UR A1 "Anchoring Equipment" was revised in parallel to and aligned with Recommendation No. 10. A new Unified Requirement A3 "Anchor Windlass Design and Testing" has been set up. Parts of Recommendation No. 10 on anchor windlass design and testing have been deleted as they will be replaced by the new UR A3.

.6 Dates:

Original Proposal: 18 September 2007 made by GPG (6111cIGb)

Panel Approval: 03 October 2016 (Ref: PH7011)

GPG Approval: 31 October 2016 (12106_IGs)

- **Rev.2 (June 2005)**

No history files or TB document available.

- **Corr.1 (December 2004)**

No history files or TB document available.

- **Rev.1 (August 1999)**

No history files or TB document available.

- **New (1982)**

No history files or TB document available.

Part B. Technical Background

List of Technical Background (TB) documents for Rec.10:

Annex 1. **TB for Revision No.3 (Oct 2016)**

See separate TB document in Annex 1.

Annex 2. **TB for Revision No.4 (Sep 2020)**

See separate TB document in Annex 2.

Annex 3. **TB for Revision No.5 (June 2023)**

See separate TB document in Annex 3.

Note: *There are no separate Technical Background (TB) documents for New (1982), Rev.1 (Aug 1999), Corr.1 (Dec 2004), Rev.2 (June 2005) and Corr.1 (Dec 2016).*

Technical Background (TB) document for Rec.10 (Rev.3 Oct 2016)

1. Scope and objectives

Due to concerns raised by the industry in view of an increasing number of incidents like anchor losses Recommendation No. 10 has been reviewed and updated. Operational practices being adopted by many owners, in particular, anchoring in deep and unsheltered waters have been considered to support the application of anchoring equipment fit for current practice. Extensive numerical calculations have been carried out to offer optional alternative anchoring equipment for anchoring in deep and unsheltered waters.

Also, due to recurrent incidents during mooring and towing, Recommendation No. 10 has been reviewed and updated. Extensive numerical calculations have been carried out to verify the minimum recommended number and strength of mooring lines given by Recommendation 10.

For further information see Attachment 1.

2. Engineering background for technical basis and rationale

See Attachment 1.

3. Source/derivation of the proposed IACS Resolution

See Attachment 1.

4. Summary of Changes intended for the revised Resolution

Recommendation No. 10 has been reviewed and updated with respect to operational practices being adopted by many owners, in particular, anchoring in deep and unsheltered waters. Based on an ABS guideline for deep water anchoring and additional numerical calculations, optional alternative anchoring equipment has been defined that can be applied for anchoring in deep and unsheltered waters.

The recommendations for wire ropes for anchors have been updated to align Recommendation No. 10 with corresponding revisions of Unified Requirement A1.

Recommendations for securing the stowed anchor have been introduced.

Recommendations for anchor windlass design and testing have been deleted as they will be replaced by the new Unified Requirement A3 "Anchor Windlass Design and Testing".

Furthermore, the recommended number and strength of mooring lines have been reviewed and updated. Based on extensive numerical calculations, new recommendations for mooring lines have been introduced for ships with an Equipment Number, EN, of more than 2000.

Recommendations on the construction of wire ropes have been deleted as considered too specific.

Recommendations on mooring and towing arrangement have been added.

With this revision also several editorial changes have been introduced.

See Attachment 1 for more detailed information.

5. Points of discussions or possible discussions

None.

6. Attachments if any

Attachment 1.

Technical background to Rec. 10 (Rev.3 Oct 2016) 'Anchoring, Mooring, and Towing Equipment'

1. Anchoring equipment

1.1. Anchoring equipment for ships having EN below 205 to 50

1.1.1. Equipment number EN

In Table 1 the minimum values for the given stream wire or chain breaking strength were adopted to ease the application. As the given values are recommended values, the minimum values given by Recommendation No. 10 Rev. 2 are considered applicable.

1.1.3. Chain cables and wire ropes for anchors

1.1.3.3. Wire ropes for anchors

The recommendations for wire ropes for anchors used instead of chain cable were simplified to align with UR A1 Revision 6. Chain cable may be replaced by wire ropes for both bower anchors for ships below 40 m in length instead of only for one of the two bower anchors for ships between 30 m and 40 m in length. An additional condition was added to UR A1 and Recommendation 10, requesting all surfaces being in contact with the wire to be rounded with a radius of not less than 10 times the wire rope diameter, including the stem, to reduce the risk of damage to the ropes. This change was performed to align IACS class requirements with respect to wire ropes for anchors and avoid reservations to this provision in UR A1.

1.2. Anchoring equipment for ships in deep and unsheltered water

Today anchoring may increasingly be performed under conditions not necessarily reflected by criteria on which the required (UR A1) or recommended (Rec. No. 10) anchoring equipment are based on. Due to high volume of trade, ships may be anchored outside the ports, where they are subjected to dynamic forces due to waves in addition to current and wind loads. The water depth at these anchorages are often much deeper, resulting in higher loads on the anchor equipment and reduced laid length of the anchor chain that may lead to anchor dragging. Thus, recommendations were introduced that may be used to design or assess the adequacy of anchoring equipment for ships intended to anchor in water with depth up to 120 m, current with up to 1.54 m/s, wind with up to 14 m/s and waves with significant height of 3 m.

These provisions are applicable to ships with an equipment length of not less than 135 m. Furthermore, the recommended anchoring equipment is subject to the following limitations:

- Wind, current, and waves from ahead and acting in the same direction.
- No strong yaw and sway motions of more than ± 10 degrees, even of low frequency.

Disregarding the above given limitations may increase the loads on the anchoring equipment and anchor dragging is to be expected.

The recommended equipment is based on 3-D time domain anchoring calculations performed for oil tankers and bulk carriers with a length of not less than 150 m. The application of the recommended anchoring equipment was extended to oil tankers, bulk carriers, and other ship types with a length of not less than 135 m by additional calculations. The calculations were performed in long-crested irregular waves using the Pierson–Moskowitz spectrum and for a range of mean zero-crossing periods between 4.5 s and 12.5 s. Calculations were performed

for loaded and ballast conditions for tankers and bulk carriers and for design draft for the other ships.

The results for the maximum calculated chain cable tensions are shown in the figure below, compared to the holding power and proof test load of the recommended high holding power (HHP) anchors and the breaking load of the recommended chain cable. The holding power is shown for efficiencies of HHP anchors in bad (2.4) and good (8.0) holding ground according to OCIMF 'Anchoring Systems and Procedures'. The anchor proof test load was determined according to UR A1 for the recommended HHP anchor weight. Also the chain cable breaking load was determined according to UR A1 for the recommended chain size and grade. It can be seen that the chain breaking loads are sufficient. The recommended HHP anchors comprise sufficient strength and holding power in good holding ground for all assessed ships.

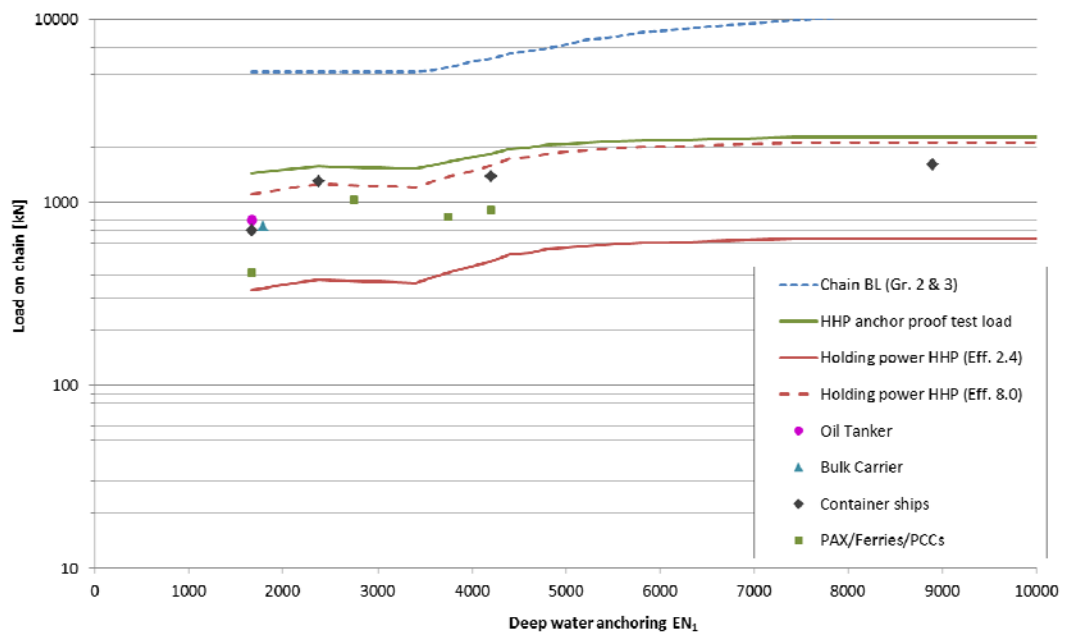

The results for the calculated minimum laid length of the chain cable are in the figure below and were found to be greater than zero in all cases. This is an important condition for the anchor to provide its maximum possible holding power.

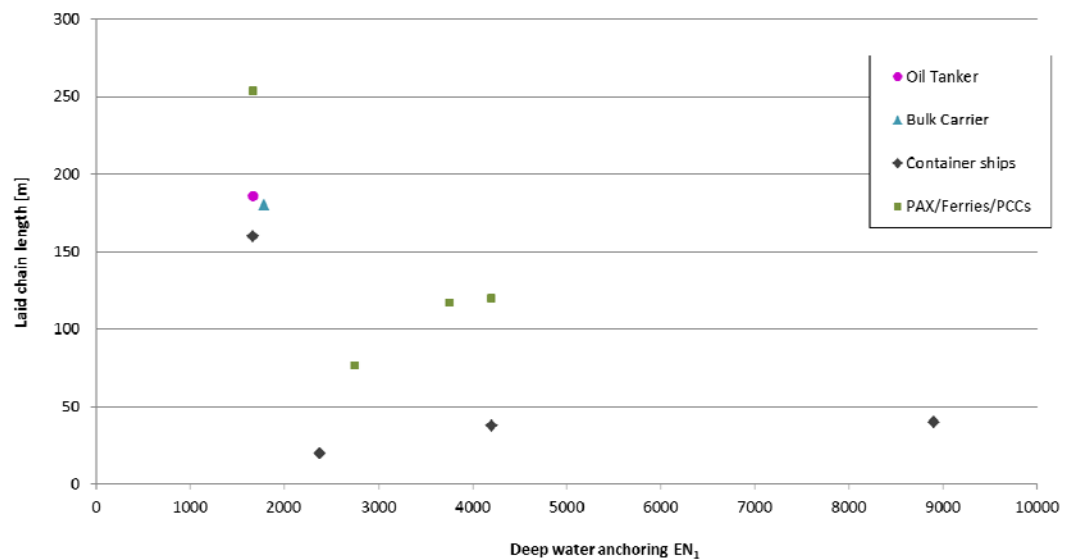

1.2.3 Anchor

Stockless High Holding Power (HHP) type anchors are recommended because of their lower weight and higher holding power compared to ordinary stockless anchors.

1.2.4 Chain cables for bower anchors

Stud link chain cables of special (Grade 2) or extra special (Grade 3) quality are recommended because of their lower volume and weight compared to normal (Grade 1) quality chain cables of the same strength.

1.2.5 Anchor windlass and chain stopper

The given recommendation for the windlass duty pull is based on the anchor and chain cable mass for a water depth of 120 m, accounting for the effects of buoyancy and hawse pipe efficiency (assumed to be 70%). The chain cable mass per length, in kg/m, is assumed to be represented by $0.0218 d^2$, where d is the chain link diameter, and resembles the mass of stud link chain cables as given by Table 3 in Recommendation No. 10.

1.3. Windlass design and testing (deleted)

This section was deleted because the contents will be covered by the new UR A3 'Anchor Windlass Design and Testing'.

1.3. Installation of the chain cables and anchors on board

1.3.3. Securing of stowed anchors

Recommendations for anchor lashings were introduced. Anchor lashings are considered to reduce anchor losses in heavy weather and to avoid possible damages to the ship hull from loose anchors. Recommendations for the strength of anchor lashings were aligned with ISO 6325 'Shipbuilding - Cable stoppers'

2. Mooring and towing equipment

2.1. Mooring lines

The recommendation for the minimum number and strength of mooring lines was separated for ships with Equipment Number $EN \leq 2000$ and $EN > 2000$. To address the increasing number of reports on problems with insufficient mooring equipment, in particular, on ships with large side-projected areas, for ships with $EN > 2000$ new recommendations were introduced for the number and strength of mooring lines.

2.1.1. Mooring lines for ships with $EN \leq 2000$

The recommended MBL was increased by a factor equal to 1.25/1.15 to account for the decrease of the safety factor in the design load for mooring in UR A2 Revision 4 from 1.25 to 1.15. The design load for substructures of mooring fittings was intended to be unchanged.

2.1.2. Mooring lines for ships with $EN > 2000$

For ships with $EN > 2000$ new recommendations for the number and strength of mooring lines were introduced based on mooring calculations performed for different ship types and sizes:

Ship type	Length b. p.	Cargo Capacity
Container ships	133 m	1,100 TEU
	197 m	2,500 TEU
	289 m	8,800 TEU
	350 m	14,100 TEU
Bulk carrier	172 m	28,000 DWT
	222 m	73700 DWT
	286 m	190,000 DWT
Tankers	245 m	115,000 DWT
	330 m	300,000 DWT
Gas carrier	130 m	10,000 m ³
	291 m	151,000 m ³
PAX/Ferries	97 m	-
	137 m	-
	222 m	-
PCC	200 m	-

For the calculation of external forces, the following environmental conditions were assumed:

- Wind with a speed of 25 m/s, representative of a 30 second mean speed (considered sufficient to overcome the inertia of the ship and to have an effect on the moorings), from any direction in 10° intervals
- Current with a speed of 1.5 m/s from ahead or astern and of 1.0 m/s from directions deviating 10° from ahead or astern (for solid piers only towards the pier).

The above criteria should account for most conditions that could be encountered in worldwide trade. They are not intended to cover extreme environmental conditions at specific terminals. Excessive winds, current, or wave loads as well as cross currents that can occur at non-solid quays (e.g., jetties) have not been considered as these depend much on the individual berth. It is recommended that designers account for this individually if a ship is expected to be moored at berths subject to such conditions. Also owners and ships' crews should consider this during a pre-mooring risk assessment.

Shipboard mooring arrangements were, as far as possible, chosen similar to those of the selected reference ships. Different mooring line types were assessed as considered common for the analyzed ship type and size, i.e. lines made of Polyamide, Polypropylene/Polyethylene, wire and High Modulus Polyethylene (HMPE). Shore side mooring facilities, e.g. bollard or hook locations, were chosen depending on the assessed ship type and size and similar to those from selected reference terminals. Non-solid piers, e.g. jetty type piers, were only considered for oil tankers. For all other ship types the pier (but no onshore structures) was considered to provide shielding with respect to offshore wind and current. For ship types that in normal operation comprise significantly different draught in loaded and ballast condition, i.e. for bulk carriers and tankers, both conditions were assessed; for other ship types the design draft was used. In calculations for container ships the side-projected area of deck cargo was accounted for.

For the calculation of current and wind forces on the ships, drag coefficients were obtained from OCIMF publications for oil tankers, bulk carriers, and gas carriers and for the other ship types from computational fluid dynamics simulations.

Quasi-static calculations were performed for the moored ships under consideration of geometric and material nonlinearities of the mooring lines, i.e. the mooring line forces were iteratively determined for the equilibrium condition.

For each assessed ship, calculations were performed for a range of mooring layouts with increasing number of lines, starting with the number of lines given by Rec. No. 10 Rev. 2. Each layout was varied to find a realistic configuration giving the maximum expectable line load. The figure below illustrates the variation of the mooring line layout for the 2500 TEU container ship employing 10 mooring lines. The same line type and size were chosen for all mooring lines. As result, for each assessed ship, maximum line loads for a range of mooring layouts with different number of lines were found.

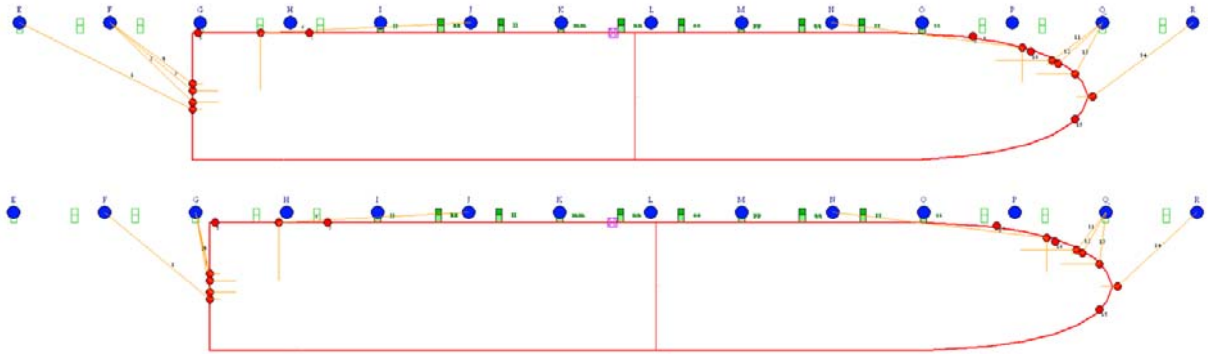

The recommended strength of mooring lines was determined based on the side-projected area instead of the Equipment Number. The Equipment Number was developed for anchoring, assuming loads coming mainly from ahead. However, this is not the critical wind load direction for breast, head, and stern lines. These lines are typically the most loaded lines and, thus, determine the necessary strength. Current loads were found to be not the main contributor to the loads acting on breast, head and stern lines. The required strength of breast, head and stern lines that resulted from the mooring calculations also showed lower standard deviation for a linear regression over side-projected area than over EN. Thus, the side projected wind area was taken as the parameter for determination of the recommended strength of mooring lines that most appropriately represents the physics.

As the wind forces acting on the ship and the resulting forces in the mooring lines are proportional to the wind area, linear relations of the strength (MBL) of lines as well as of the number of head, stern, and breast lines and side-projected area were established. While the minimum recommended number of head, stern, and breast lines is based on the side-projected area, the number of spring lines is still determined based on the EN because the latter can be considered to represent loads acting from ahead or astern.

The minimum recommended MBL includes a margin of 1.82 for wear and tear and uncertainties in loading, i.e. the maximum expected mooring line force should not exceed 55% of the mooring line MBL, following OCIMF 'Mooring Equipment Guidelines'. The following diagram shows the resulting maximum loads in head, stern, and breast lines, including the margin of 1.82, for the associated number of lines on which the recommended number of head, stern, and breast lines was based. The recommended MBL is shown as blue line:

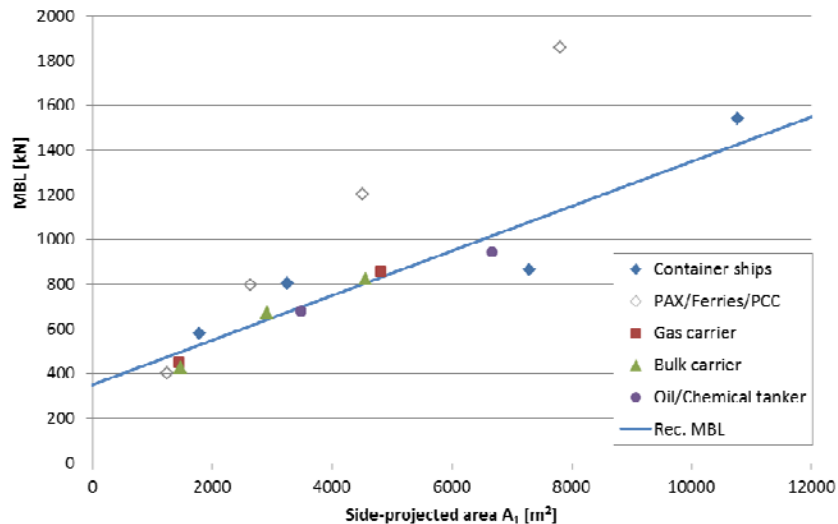

The recommended MBL may be limited to 1275 kN (130 t) to allow for the use of common mooring line sizes. However, in this case the moorings are to be considered as not sufficient for the given environmental conditions and the acceptable wind speed needs to be reduced.

For passenger ships, ferries, and car carriers with side-projected area larger than 2000 m² the acceptable wind speed was reduced down to 21 m/s due to excessive mooring line loads calculated for these ships with 25 m/s and usual mooring arrangements.

Additional means may need to be taken in case of worse environmental conditions, i.e. using storm bollards, requesting tug assistance, leaving or not entering port, etc., in order to prevent the ship to come loose from its moorings. It should be noted that, when using storm bollards, the mooring arrangement should be adjusted such that the lines paid out to the storm bollards are enabled to carry the main abeam mooring loads.

For the case that lines are intended to be supplied for an acceptable wind speed, higher than the wind speed on which the minimum recommendations are based, provisions are given for the determination of corresponding MBL.

The strength of spring lines was taken as for breast, head and stern lines. For the minimum recommended number of spring lines the required strength was found to be similar or less than that required for breast, head, and stern lines. It was presumed that all mooring lines onboard a ship should have the same strength in order to prevent confusion.

The information on the acceptable wind and current speed is considered important for the ship's crew, in particular, of large ships to be aware of the limitations of the mooring equipment. This enables the early preparation of countermeasures in the case of deteriorating weather conditions in order to prevent the ship to come loose from its moorings. Thus, UR A2 Rev. 4 requests to mention the acceptable wind and current speed on the 'Towing and mooring arrangements plan' and the pilot information.

For the number of head, stern, and breast lines, different relations were established for tankers, bulk carriers, and ore carriers on the one hand and other ships on the other hand. This is owed to the relatively low line loads observed for the former ship types that are considered to be caused by relatively beneficial wind drag coefficients and mooring line leads. The diagram below shows the number of head, stern, and breast lines for the associated maximum loads in the lines on which the recommended MBL was based. The recommended numbers of head, stern and breast lines are shown as blue and green lines:

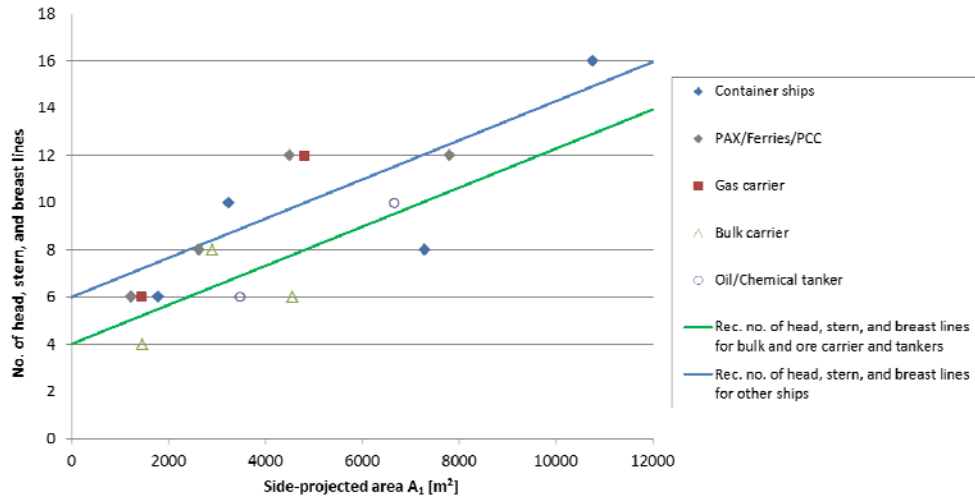

The number of spring lines according to the calculation results corresponding to the recommended MBL and number of head, stern and breast lines are compared to the recommended number of spring lines (blue curve) in the diagram below:

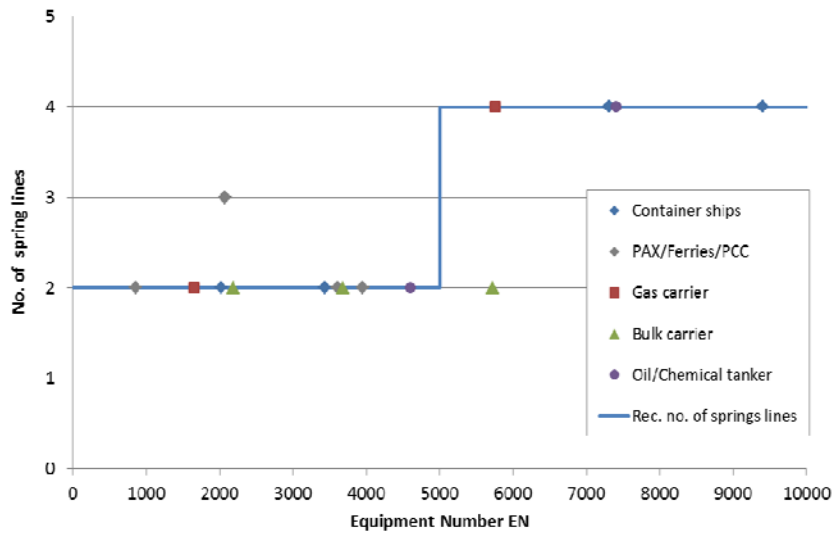

The recommended MBL and total number of lines were compared for several ships of different sizes and types to the recommended lines in Recommendation No. 10 Rev. 2 and the actually supplied lines onboard these ships. The diagrams below show the ratio of MBL according to Rec. No. 10 Rev. 3 and Rev. 2 (left) and the ratio of the MBL according to Rec. No. 10 Rev. 3 and that of the actually supplied lines (right):

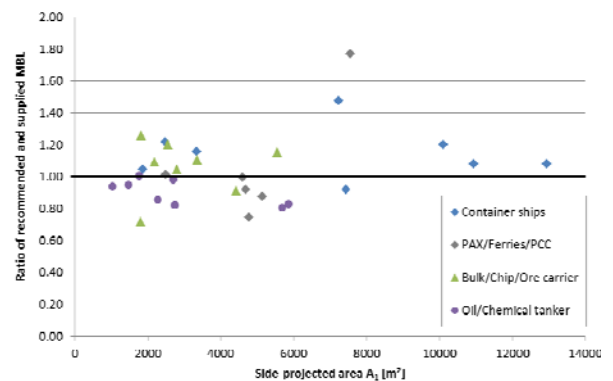
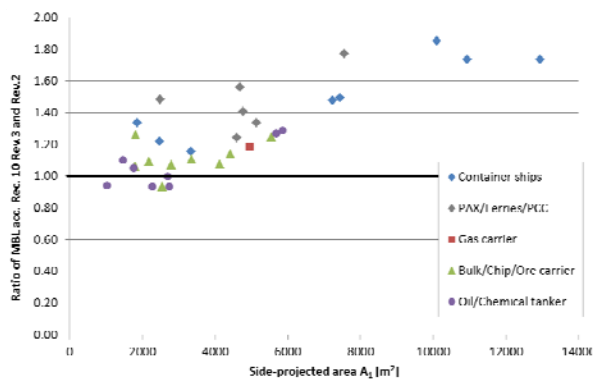

The diagrams below show the ratio of total number of lines according to Rec. No. 10 Rev. 3 and Rev. 2 (left) and the ratio of total number of lines according to Rec. No. 10 Rev. 3 and that of the actually supplied lines (right):

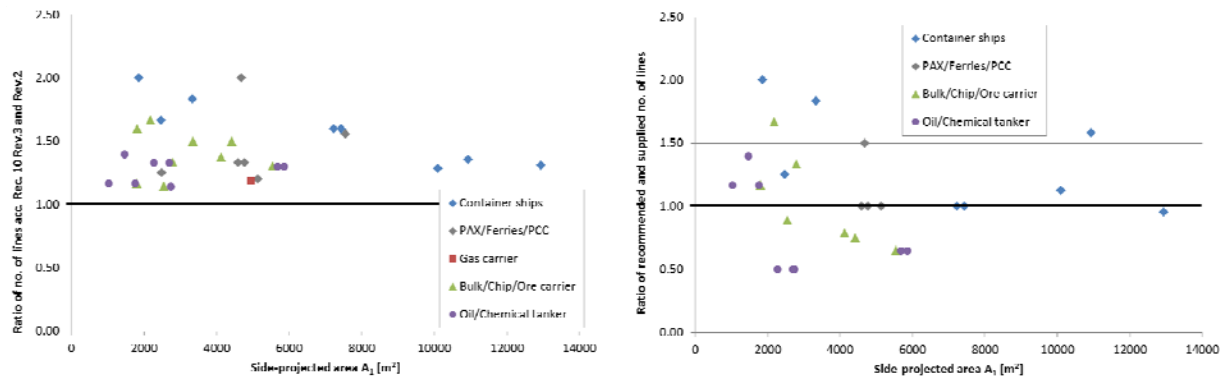

The number of lines may be increased or decreased in conjunction with an adjustment to the strength of the lines or, vice versa, strength of the lines may be increased or decreased in conjunction with an adjustment to the number of lines. However, for an increase of the number of lines, a disproportional decrease of the strength is considered. Often, the additional lines need to be attached to unfavourably located shore bollards or hooks resulting in less effective line leads than for the other lines. In these cases, the increase of number of lines is less effective in terms of reducing the maximum mooring line load than could be expected from the nominal increase of number of lines. This is illustrated by the lower two diagrams. The left diagram shows the maximum mooring line loads found for four container ships calculated with varied number of head and stern lines. In the diagram on the right hand side the relative increase or decrease of the mooring line load times the relative increase of the number of head and stern lines is shown over the relative increase of the number of head and stern lines. Values above 1.0 indicate that the effect of an increased number of lines on the maximum mooring line load is disproportionally small. Similar to other assessed ship types, a disproportionality factor of 1.2 was found to represent this effect.

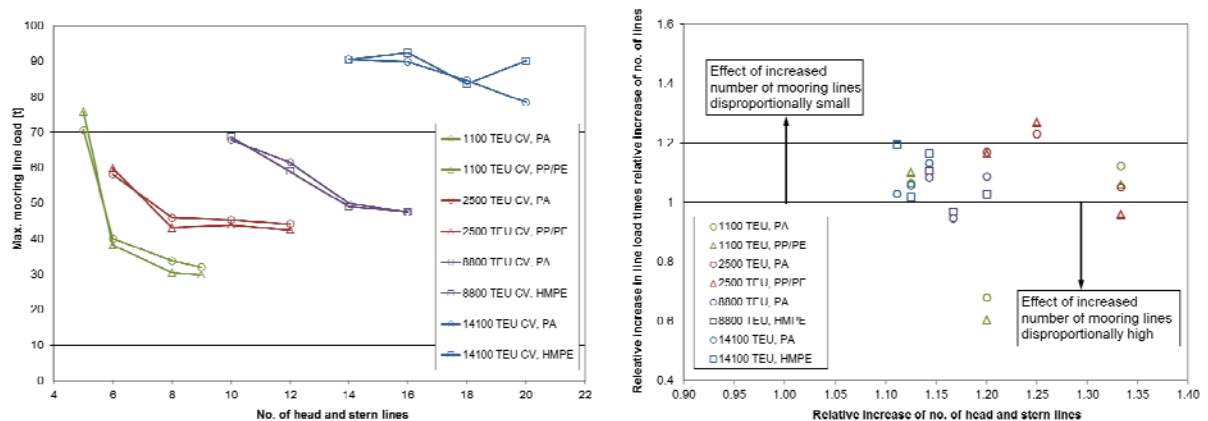

2.3. Mooring and towing ropes construction

For synthetic fibre ropes it is recommended to use lines with reduced risk of recoil (snap-back) to mitigate the risk of injuries or fatalities in the case of breaking mooring lines. Recoil is the tendency of the broken ends of a tensioned rope to draw back rapidly after break. The performance of ropes designed to have reduced-recoil-risk properties may be demonstrated, e.g., based on Cordage Institute Standard CI 1502.

For polyamide ropes it is recommended to increase the minimum breaking strength by 20% and for other synthetic ropes by 10% to account for strength loss due to aging and wear and, in case of polyamide, also for strength loss of the rope when wet. These recommendations

follow OCIMF 'Mooring Equipment Guidelines'. The increase of the minimum breaking strength needs not to be taken into account for the loads applied to shipboard fittings and supporting hull structure in UR A2 because this increase is related exclusively to the expected strength loss of the rope and not to uncertainties in the load.

2.4. Mooring winches

Mooring winches are recommended to be fitted with brakes that will allow for the reliable setting of the brake rendering load, following OCIMF 'Mooring Equipment Guidelines'. Reliably set winch brakes enable rendering of a highly loaded line and, thus, allows it to shed load before it brakes. This also improves the efficient distribution of the loads to all lines in the same service.

2.5 Mooring and towing arrangement

This section was added to provide basic guidance for the arrangement of mooring and towing equipment. The recommendations are based on input from an IACS joint working group with different representatives of the maritime industry as well as on the joint 'Guidelines on Design and Layout of Harbour Towing Equipment' of the European Tugowners Association and the European Maritime Pilots' Association.

3. Anchoring and mooring equipment for special purpose ships - fishing vessels

3.1. Anchoring equipment

3.1.3. Particular recommendations

The recommendations for wire ropes for anchors used instead of chain cable were aligned with the changes to 1.1.3.3.

3.2. Mooring equipment

In Table 8 the minimum values for the given mooring line breaking strength were adopted to ease the application. As the given values are recommended values, the minimum values given by Recommendation No. 10 Rev. 2 are considered applicable.

Technical Background for Rec. 10 (Rev.4 Sep 2020)

1. Scope and objectives

The scope of this revision is to correct typo in table 4 related to anchoring equipment for ships in unsheltered water with depth up to 120m, add back the UR A3 references in paragraph 1.2.5, and to clarify the determination of deck cargoes side projected area in paragraphs 2.1 and 2.1.2.

In addition, to introduce a new appendix for direct mooring analysis in 2.1, to clarify the ship draft to be considered for the determination of the side projected area A1, and to amend paragraph 2.1.2.2 to correct the unreasonably excessive number of spring lines obtained as resulting from the calculation using Rev.3.

Finally, to clarify the "MBL*" different designations utilized in paragraphs 2.1.2.1 and 2.1.2.2 and to align, where found necessary with MSC.1/Circ.1175/Rev.1. The term Minimum Breaking Strength (MBL) is replaced by the term Ship Design Minimum Breaking Load (MBL_{SD}) throughout the document.

2. Engineering background for technical basis and rationale

The identified typo in table 4 related to anchoring equipment for ships in unsheltered water with depth up to 120m has been corrected based on ABS Guide on Deep Water Anchoring For Oil Tankers And Bulk Carriers (DWA) July 2015 Edition, table 1.

In paragraph 1.2.5, where Z_{cont} is larger than the duty pull required by 3.1.2 of UR A3, this Z_{cont} should be applied for the design torque-transmitting components and the calculation of overload capacity.

For testing purpose the requirements in 1.2.5 should be applied in addition to the requirements stated in UR A3 paragraph 3.1.4.

The determination of the deck cargoes side projected area in paragraphs 2.1 and 2.1.2 have been clarified introducing the definition of the condition to be considered. The side projected area of deck cargoes should be determined for the ship nominal capacity condition. The nominal capacity condition is defined in UR A2.0 Application and definitions.

The side projected area of the deck cargoes at nominal capacity condition should be presented in the ship arrangement (i.e. GA, Capacity Plan, Container Stowage Plan, etc.) being or not being part of a ship's manual (trim and stability booklet, loading manual, cargo securing manual, etc.).

The calculation of the EN referred to in UR A2 and Rec.10 for towing and mooring is to be performed considering the side projected area of deck cargoes at nominal capacity condition combined with summer load line with even keel.

It has been agreed in the Hull Panel that it's reasonable to allow mooring loads to be determined based on direct analysis and a new Appendix A is introduced to

define the conditions for such analysis. The direct calculation of mooring forces may be considered as a fully effective alternative to the requirements given in 2.1.1 and 2.1.2 of Rec.10, provided that the assessments are made considering the environmental conditions, mooring layout and berthing situation etc. as mentioned in Appendix A.

Users of UR A2 and Rec.10 have questioned which draft shall be used for the calculation of side projected area A_1 for gas carriers.

In general the side projected area for mooring equipment shall be calculated as for equipment number, but some exceptions are given in Rec.10 and the question is related to this paragraph in Rev.3 of Rec.10:

"For oil tankers, chemical tankers, bulk carriers, and ore carriers the lightest ballast draft should be considered for the calculation of the side-projected area A_1 . For other ships the lightest draft of usual loading conditions should be considered if the ratio of the freeboard in the lightest draft and the full load condition is equal to or above two. Usual loading conditions mean loading conditions as given by the trim and stability booklet that are to be expected to regularly occur during operation and, in particular, excluding light weight conditions, propeller inspection conditions, etc."

For gas carriers and several other cargo ships the ratio between freeboard in the lightest draft and full load condition is less than two and consequently it would be sufficient to calculate the mooring loads based on the reduced area in full load condition. This simplification was introduced to allow the same draft to be used for equipment number calculations and mooring load determination.

Looking into this again it was found that for some ship types the mooring loads in ballast conditions may be significantly underestimated with the procedure given in Rec.10 Rev.3 and for this reason it was decided to update the recommendation.

In Rev.4 it is clarified that side projected area, A_1 , in general shall be calculated on lightest ballast draft unless cargo is considered in the calculation of the area. In addition, for ship with small variation in draft, e.g. passenger or RO/RO vessels, the side projected area can be calculated at full load draft as considered for the equipment number. The consideration related to ships with small variation in draft is introduced to avoid a new change of calculation procedure and mooring requirement for ships where side projected area does not vary much between different loading conditions.

IACS Member and Industry identified that Rec.10 requires somewhat excessive number of spring lines which shall not be considered proportional to the number of head/stern/breast lines. In some cases smaller size ships are to be fitted with more spring lines than bigger size ships which is unreasonably. Case studies have been performed in order to support IACS decision and are enclosed in item 6 of this TB.

It has been identified through paragraph 2.1.2.2 that once the number of head/stern/breast lines is increased for adjustment of the strength of these lines the number of spring lines also needs to be likewise increased. IACS concluded

that the spring lines should not be adjusted by the same formula as head/stern/breast lines based on the following:

- While the number of head/stern/breast lines is based on the side-projected area the number of spring lines is based on EN once this represent the load acting from ahead or astern; the acting characteristics of head/stern/breast lines and spring lines are so different..
- The factor "1.2" for increasing number of lines is provided due to the consideration of disproportionality in order to equally share the acting force on each mooring line as explained in the TB of Rev. 3. This can only be considered valid for head/stern/breast lines.

It is not considered to be theoretical that the increase/decrease of the number of spring lines is based upon the same formula as head/stern/breast lines using the disproportionality factor of 1.2; rather it should be determined using the footnote of Table 5 of Rec.10 Rev.2, i.e., the number of spring lines may be increased corresponding to the reduction of the strength of these lines, provided that the total breaking load considering all spring lines is not less than the Rules value ($MBL^* \cdot n^* = MBL \cdot n$).

Clarification of "MBL*" in paragraphs 2.1.2.1 and 2.1.2.2 is necessary to distinguish its different purposes accordingly:

- the breaking strength of the mooring lines intended to be supplied for adjustment of the "environmental condition" in accordance with paragraph 2.1.2.1; and
- the minimum breaking strength required as a result of adjustment of "number of lines" in accordance with paragraph 2.1.2.2, which is not necessarily the same as the breaking strength of the mooring lines intended to be supplied.

The clarification of "MBL*" has been solved through the introduction of a new symbol "MBL**" in 2.1.2. while the designation of "MBL*" have been kept to its original purpose, breaking strength of the mooring lines intended to be supplied for adjustment of the "environmental condition", in 2.1.2.1 also corresponding to the modified acceptable wind speed, v_w^* , and v_w^* referenced in UR A2..

The paragraph 2.1.2.1 of Rec.10 says: "The minimum breaking strength may be limited to 1275 kN (130 t). However, in this case the moorings are to be considered as not sufficient for environmental conditions given by 2.1.2"

In addition to the TB Attachment 1 to Annex 1 - Technical background to Rec. 10 (Rev.3 Oct 2016) 'Anchoring, Mooring, and Towing Equipment' item 2.1.2 the following clarification is applicable for the above statement:

The recommended MBL may be limited to 1275 kN (130 t) to allow for the use of common mooring line sizes. However, in this case the moorings are to be considered as not sufficient for the given environmental conditions and the acceptable wind speed needs to be reduced.

The 120 t - 130 t breaking load is a usual strength of lines applied, e.g., on larger container ships. The mooring lines available with strength well above 130 t are often high modulus lines that have low elasticity. High modulus lines can have very high strength with moderate diameters. To increase elasticity, high modulus lines are usually used together with more elastic tails.

In order to limit the impact on the mooring equipment and to enable the use of standard (no high modulus) mooring lines for larger ships, it was deemed worthwhile to offer the possibility to reduce the recommended acceptable wind speed down to 21 m/s, but not less.

Mooring lines with MBL bigger than 1275 kN are considered to be of uncommon supply and for this reason an alternative procedure with a limiting MBL value of 1275 kN has been proposed for cases when calculated MBL values are greater than 1275 kN. This alternative procedure is not applicable to mooring lines with calculated MBL values smaller than 1275 kN.

3. Source/derivation of the proposed IACS Resolution

IACS Rec.10 Rev.2 and Rev3

ABS Guide on Deep Water Anchoring for Oil Tankers and Bulk Carriers (DWA)
July 2015 Edition, table 1.

4. Summary of Changes intended for the revised Resolution:

Table 4: Mass per anchor and Min. diameter

Table 4 Anchoring equipment for ships in unsheltered water with depth up to 120 m

Equipment Number EN ₁		High holding power stockless bower anchors	Stud link chain cable for bower anchors			
EN ₁	EN ₂	Number	Mass per anchor (m _A) (kg)	Length (m)	Min. diameter (d)	
					Special quality (Grade 2) (mm)	Extra special quality (Grade 3) (mm)
1790	1790	2	14150	1017.5	105	84
1930	1930	2	14400	990	105	84
2080	2080	2	14800	990	105	84
2230	2230	2	15200	990	105	84
2230	2380	2	15600	990	105	84
2380	2530	2	16000	990	105	84
2530	2700	2	16300	990	105	84
2700	2870	2	16700	990	105	84
2870	3040	2	17000	990	105	84
3040	3210	2	17600	990	105	84
3210	3400	2	18000	990	105	84
3400	3600	2	18300	990	106.5	84
3600	3800	2	19000	990	107	85.7
3800	4000	2	19700	962.5	108.7	87
4000	4200	2	20300	962.5	111	90
4200	4400	2	21100	962.5	114	92
4400	4600	2	22000	962.5	117	95
4600	4800	2	22900	962.5	119.20	97
4800	5000	2	23500	962.5	122.4	99
5000	5200	2	24000	935	125.7	102
5200	5500	2	24500	907.5	130.2	105.7
5500	5800	2	25000	907.5	133.2	107
5800	6100	2	25500	880	137	111
6100	6500	2	25700	880	140.2	113.4
6500	6900	2	26000	852.5	143.2	115.7
6900	7400	2	26500	852.5	147	118.7
7400	7900	2	27000	825	152	121.2
7900	8400	2	27500	825	154	123.27
8400	8900	2	28000	797.5	158	127
8900	9400	2	28900	770	162	132
9400	10000	2	29400	770	-	135.7
10000	10700	2	29900	770	-	139.42
10700	11500	2	30600	770	-	143.2
11500	12400	2	31500	770	-	147
12400	13400	2	33200	770	-	152
13400	14600	2	35000	770	-	157
14600		2	38000	770	-	162

Paragraph 1.2.5:

The application of UR A3 is recommended for the anchor windlass design and testing and the chain stopper design reference is made to UR A3.

Notwithstanding the requirements according to UR A3, the windlass unit prime mover should be able to supply for at least 30 minutes a continuous duty pull Z_{cont} , in N, given by:

$$Z_{cont} = 35 d^2 + 13.4 m_A$$

where

d = chain diameter, in mm, as per Table 4

m_A = HHP anchor mass, in kg, as per Table 4

In addition to the requirements of UR A3, as far as practicable, for testing purpose the speed of the chain cable during hoisting of the anchor and cable should be measured over 37.5 m of chain cable and initially with at least 120 m of chain and the anchor submerged and hanging free. The mean speed of the chain cable during hoisting of the anchor from the depth of 120 m to the depth of 82.5 m should be at least 4.5 m/min.

For the hull supporting structure of anchor windlass and chain stopper reference is made to A1.7.

Paragraph 2.1:

The Equipment Number EN should be calculated in compliance with A1.2. Deck **cargoes at the ship nominal capacity condition as given by the loading manual** should be included for the determination of side-projected area A. **The nominal capacity condition is defined in UR A2.0.**

Sections 2.1.1 and 2.1.2 specify the minimum recommended number and minimum strength of mooring lines. As an alternative to [2.1.1] and 2.1.2, the minimum recommendation for mooring lines may be determined by direct mooring analysis in line with the procedure given in Appendix A.

The ship owner should consider verifying the adequacy of mooring lines based on assessments carried out for the individual mooring arrangement, expected shore-side mooring facilities and design environmental conditions for the berth.

Paragraph 2.1.2:

- ~~For oil tankers, chemical tankers, bulk carriers, and ore carriers~~ **The lightest ballast draft should be considered for the calculation of the side-projected area A₁. For other ships types having small variation in the draft, like e.g. passenger and RO/RO vessels, the side projected area A₁ may be calculated using the summer load waterline. having the lightest draft of usual loading conditions should be considered if the ratio of the freeboard in the lightest draft and the full load condition is equal to or above two. Usual loading conditions mean loading conditions as given by the trim and stability booklet that are to be expected to regularly occur during operation and, in particular, excluding light weight conditions, propeller inspection conditions, etc.**
- Deck **cargoes at the ship nominal capacity condition as given by the loading manual** should be included for the determination of side-projected area A₁. **For the condition with cargo on deck, the summer load waterline may be considered.** Deck **cargoes** may not need to be considered if ~~a usual light ballast draft condition without cargo on deck~~ generates a larger side-projected area A₁ than the full load condition with cargoes on deck. The larger of both side-projected areas should be chosen as side-projected area A₁. **The nominal capacity condition is defined in UR A2.0.**

Paragraph 2.1.2.2:

The number of head, stern and breast lines may be increased or decreased in conjunction with an adjustment to the ship design minimum breaking load of the lines. The adjusted ship design minimum breaking load, MBL_{SD}^{**}, should be taken as:

$$MBL_{SD}^{**} = 1.2 \cdot MBL_{SD} \cdot n/n^{**} \leq MBL \text{ for increased number of lines,}$$

$MBL_{SD}^{**} = MBL_{SD} \cdot n/n^{**}$ for reduced number of lines.

where **MBL_{SD} is MBL_{SD} or MBL_{SD}*** specified in 2.1.2.1, as appropriate, n^{**} is the increased or decreased total number of head, stern and breast lines and n the number of lines for the considered ship type as calculated by the above formulas without rounding.

The ship design minimum breaking load of spring lines should be the same as that of the head, stern and breast lines. If the number of head, stern and breast lines is increased in conjunction with an adjustment to the ship design minimum breaking load of the lines, the number of spring lines should be **taken as follows likewise increased**, but rounded up to the nearest even number.

$$n_s^* = MBL_{SD}/MBL_{SD}^{**} \cdot n_s$$

where **MBL_{SD} is MBL_{SD} or MBL_{SD}*** specified in 2.1.2.1, as appropriate, n_s is the number of spring lines as given above and n_s^* the increased number of spring lines.

5. Points of discussions or possible discussions

None

6. Attachments, if any

None

Technical Background (TB) document for Rec 10 (Rev. 5, June 2023)

1. Scope and objectives

The scope of this revision is to introduce a new appendix for direct calculation for the selection of anchoring equipment (Anchor and chain cable). This appendix will be introduced in UR A1 as alternative to anchoring equipment selection using Equipment Number calculation for ships less than 90m.

2. Engineering background for technical basis and rationale

See Attachment 1.

2a. Specification of the data utilised in the development/revision of the proposed IACS Resolution, if any

None

3. Source/derivation of the proposed IACS Resolution

IACS Member.

4. Summary of Changes intended for the revised Resolution:

New appendix for selection of anchoring equipment based on direct calculation.

5. Points of discussions or possible discussions

Discrepancies between results according to methodology chosen. Clarification of some definitions

6. Attachments if any

See Attachment 1.

Attachment 1: New formula of equipment calculation

1. REGULATORY CALCULATION OF THE EQUIPMENT NUMBER

1.1. Introduction

The regulatory calculation of the equipment number is based on a simplified formula that is supposed to represent the effects of wind and current.

1.2. Regulatory formula for equipment number calculation

The formula in IACS URA1 for cargo ship is:

$$EN = \Delta^{2/3} + 2.0(hB + S_{fun}) + \frac{A}{10}$$

And the formula in IACS URA1 for tug is:

$$EN = \Delta^{2/3} + 2.0 \left(aB + \sum h_i b_i \right) + \frac{A}{10}$$

with

Δ	moulded displacement, in t, to the Summer Load waterline,
B	moulded breadth, in m,
h	effective height, in m, from the Summer Load waterline to the top of the uppermost house,
h_i	height, in m, on the centerline of each tier of houses having a breadth greater than B/4,
b_i	breadth, in m, of the widest superstructure or deckhouse of each tier having a breadth greater than B/4,
S_{fun}	effective front projected area of the funnel, in m ² ,
A	Side surface of the ship, in m ² .

In these formulae the term $\Delta^{2/3}$ represents the influence of the current on the hull, the term $2.0(hB + S_{fun}) + 0.1 \cdot A$ represents the influence of lateral windage.

This Equipment Number takes into account the following assumptions:

- mooring is done in calm waters (no swells),
- the wind is considered to be at a speed of 50 knots,
- It is considered that the current has a speed of 5 knots,

Once the Equipment number is known, one should refer to Table 1 of UR A1 in order to know the values governing the Equipment Number. These values give the average Equipment Number to be taken into account for the continuation of the determination of the Equipment, called EN_{moy} .

The anchor weight, in kg, for an ordinary anchor is then taken equal to $3 \cdot EN_{moy}$, and this weight is reduced by 25% for a HHP anchor (High Holding Power) and 50% for a VHHP anchor (Very High Holding Power).

It then comes $P_{ordi} = 3 \cdot EN_{moy}$
 $P_{HHP} = 2.25 \cdot EN_{moy}$
 $P_{VHHP} = 1.5 \cdot EN_{moy}$

The chain cable diameter, in mm, is calculated according to the steel grade as follows:

$$D_{Q1} = 1.75 \cdot \sqrt{EN_{moy}}$$

$$D_{Q2} = 1.55 \cdot \sqrt{EN_{moy}}$$

$$D_{Q3} = 1.375 \cdot \sqrt{EN_{moy}}$$

The resistance to chain cable breakage, in kN, (Breaking Load) is calculated with the following formulas:

$$BL_{Q1} = 9.80665 \cdot 10^{-3} [D^2 \cdot (44 - 0.08 \cdot D)]$$

$$BL_{Q2} = 1.4 \cdot BL_{Q1}$$

$$BL_{Q3} = 2 \cdot BL_{Q1}$$

These formulas are given in Table 4 of URA1 and equivalent to the values given in Table 5 of URA1.

2. DIRECT CALCULATION OF EQUIPMENT

2.1. Introduction

The direct calculation of the ship's Equipment is based on the static forces of the ship under the same conditions as the regulatory calculation. These conditions include:

- anchoring is done in calm waters (no swells),
- the wind is considered to be at a speed of 50 knots,
- the current is considered to have a speed of 5 knots.

Once the static force, in kN, exerted on the ship have been determined, dynamic effects such as pitching of the bow are considered by multiplying this force by 2.

It then comes $F_{tot} = 2 \times F_{stat}$

Then, according to literature, the weight of the anchor in kg is determined knowing that:

- an ordinary anchor can withstand a traction load equal to 7 times its weight,
- a high-holding anchor can withstand a traction load equal to 10 times its weight,
- and a very high-holding anchor can withstand a traction load equal to 15 times its weight.

It then comes $P_{ordi} = \frac{F_{tot}}{7} \times 100 = \frac{2}{7} \times F_{stat} \times 100$,

$$P_{HHP} = \frac{2}{10} \times F_{stat} \times 100,$$

$$P_{VHHP} = \frac{2}{15} \times F_{stat} \times 100.$$

Direct calculation does not directly give the diameter of the chain cables that should be installed. On the other hand, it is possible to determine the minimum breaking load of the chain cable in kg by assuming that this breaking load should be about 6 times the total force, or 12 times the static force. It then comes $BL_{chaîne} = 12 \cdot F_{stat}$.

It is then possible to determine the chain cable diameter to be installed based on table 4 and table 5 of UR A1 for different steel grades.

The first step will be to determine the efforts of the wind and current on the vessel.

2.2. Forces on the ship's front faces due to wind

The forces acting on the ship due to wind are of two types: the forces due to the dynamic pressure of the wind and the forces due to friction. These two forces do not occur in the same places: pressure efforts act on the front faces of the ship (emerged hull, superstructures) while friction forces act on the side of the ship.

Efforts due to wind pressure on a given flat surface are expressed as follows, in N:

$$F = P \cdot S$$

with

P	Pressure on the surface,
S	Total area of the surface under consideration,
F	Force on the surface.

At this stage it should be noted that the component of the force that is being sought is the horizontal component, so it is useless to consider the total surface of the plane and it is necessary to take the vertical projected surface of the plane.

The pressure on the plane is proportional to the dynamic pressure and is expressed as follows:

$$P = C_p \cdot P_{dyn}$$

with

C_p	Pressure coefficient,
P_{dyn}	Dynamic pressure generated by the flow and equal to $\frac{1}{2} \cdot \rho \cdot V^2$

with

ρ	Air density, taken equal to $1.22 \text{ kg}\cdot\text{m}^{-3}$,
V	Wind speed, in $\text{m}\cdot\text{s}^{-1}$.

The force generated by the wind pressure on the front faces of the ship is expressed, in N, by the formula:

$$F = \frac{1}{2} \cdot \rho \cdot V^2 \cdot \sum_i C_{p,i} S_{projected,i}$$

The next step is to determine for the different front surfaces of the ship what will be the value of C_p to choose. To this end, we will consider all the faces of the ship: both the front faces and the rear faces will participate in the global drag effort that is exerted on the ship.

The different surfaces to consider in the formula are:

- front surface of the emerged part of the hull,
- front surfaces of vertical superstructures,
- front surfaces of slopped superstructures,
-

For the front emerged part of the hull, the angle α between the direction of the flow and the middle plane of the bow, as in the figure below, is to be considered. And C_p it is equal to $0.8 \cdot \sin \alpha$.

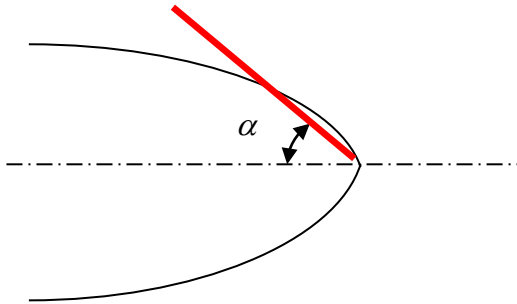

For vertical superstructures, C_p is simply equal to 0.8.



For slopped superstructures, the angle α between the direction of the flow and the average plane of the superstructure is to be considered, as in the figure below. And C_p is equal to $0.8 \cdot \sin \alpha$.



The rear sides of the superstructures and hull must also be taken into account because of the suction effects due to the flow around them. In this case, the value of the structure C_p will depend both on the angle with the flow plane but also on the lengthening of the structure under consideration.

2.3. Forces on the side faces of the ship due to wind

After the calculation of forces due to wind on front faces, the problem is now to evaluate the forces due to wind on the lateral parts of the ship. According to construction industry, these efforts are expressed as follows, in N:

$$F = \frac{1}{2} \cdot \rho \cdot V^2 \cdot \sum_i C_{f,i} \cdot S_{latérales,i}$$

with

- ρ air density, taken equal to 1.22 kg.m^{-3} ,
- $C_{f,i}$ Coefficient of friction, taken equal to 0.02 for the hull (smooth) and 0.08 (rough) for the superstructures,
- V Wind speed, in m.s^{-1} ,
- $S_{lat,i}$ Lateral partial surface of the emerged shell or superstructures, in m^2 .

For determining the lateral surface to be taken into account, it is considered that the friction occurs beyond a certain distance from the leading edge of the structure, which is equal to the smallest of the following values:

- Twice the width of the structure,
- 4 times the height of the structure.

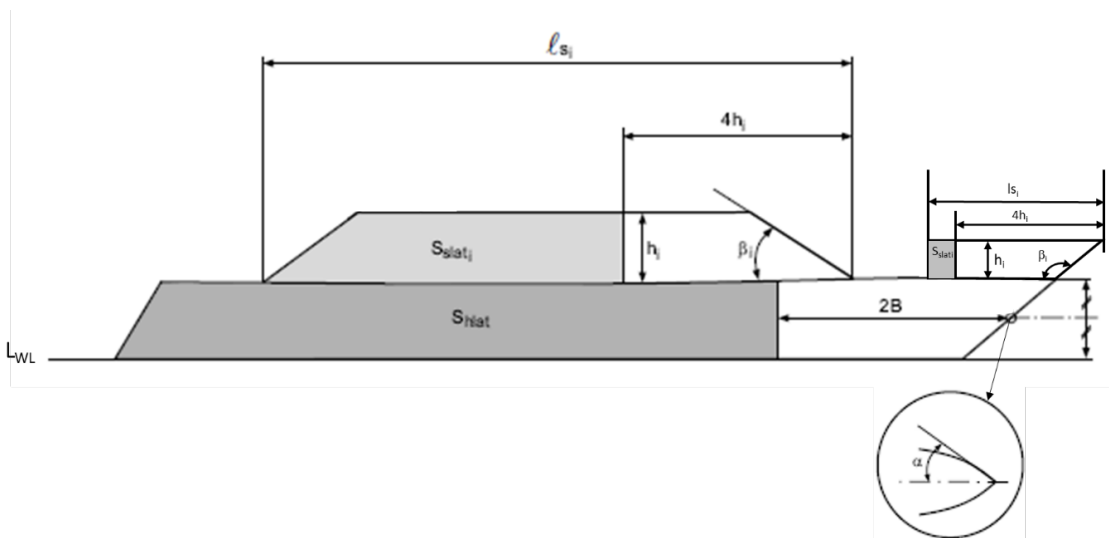

Typically for a ship, this distance is equal to 2 times the width of the hull for it, and 4 times the height of the superstructures on them, as shown in the figure above. It is therefore important to ensure that these surfaces that do not participate in friction efforts are removed from the surface of the hull and superstructures.

2.4. Forces on ship's hull due to current

Concerning the forces due to current on the wetted part of the hull, only forces due to friction are considered and expressed as follows, in N:

$$F = \frac{1}{2} \cdot \rho \cdot C_f \cdot S_m \cdot V^2$$

With following coefficients available in the literature:

- ρ water density, taken equal to 1025 kg.m⁻³,
- V Current speed, in m.s⁻¹,
- S_m Wet surface of the hull, in m², can be taken equal to $6 \cdot \Delta^{2/3}$ in the absence of more accurate data,
- C_f Friction coefficient, given by the following formula:

$$C_f = (1 + k) \cdot \frac{0.075}{(\log(\text{Re}) - 2)^2}$$

With

- Re Reynolds number, equal to $\frac{V \cdot L'}{\nu}$,
- k Shape coefficient, equal to $0.017 + 20 \cdot \frac{C_b}{\left(\frac{L}{B}\right)^2 \cdot \sqrt{\frac{B}{T}}}$,

With

- V Flow speed, in m.s⁻¹,
- L' Length of the ship at flotation, in m,
- ν Kinematic water viscosity, equal to $1,054 \times 10^{-6}$ m².s⁻¹,
- C_b Ship's block coefficient,
- L Regulatory length of the ship, in m,
- B Width of the ship, in m,
- T Moulded draught of the ship, in m.

2.5. Equipment calculation

As stated in the introduction, once all the static efforts on the ship are known, the first elements of the Equipment (anchor weight and chain cable breaking load) can be expressed in the following way, after expressing static effort in kilograms:

$$\begin{aligned}
P_{ordi} &= \frac{F_{tot}}{7} \times 100 = \frac{2}{7} \times F_{stat} \times 100, \\
P_{HHP} &= \frac{2}{10} \times F_{stat} \times 100, \\
P_{VHHP} &= \frac{2}{15} \times F_{stat} \times 100, \\
BL_{chaîne} &= 12 \cdot F_{stat}
\end{aligned}$$

And from the chain cable breaking load we can deduce the diameter of chain cables from Table 4 and table 5 of UR A1 for different steel grades.

3. COMPARISONS BETWEEN THE TWO METHODS

3.1. Introduction

The purpose of this comparison is to validate the new formulation of the Equipment calculation, by comparing what can be achieved using regulatory calculation on one hand and direct calculation on the other.

3.2. Assumptions of the regulatory calculation

In addition to comparing the two methods, comparing regulatory and direct calculations can be a way to identify some assumptions of the regulatory calculation.

First, the relationship between the Equipment Number EN and the total force F_{tot} , in F kN, that is exerted on the ship is expressed by the following formula:

$$EN \approx 4.5 \cdot F_{tot}$$

This formula can be found in two different ways, one of which is the comparison between the anchor weight that one obtains using the regulatory formula on the one hand and the formula of direct calculation on the other:

$$P_{ordi} = 3 \cdot EN_{moy}; P_{HHP} = 2.25 \cdot EN_{moy} ; P_{VHHP} = 1.5 \cdot EN_{moy} \text{ and}$$

$$P_{ordi} = \frac{2}{7} \cdot F_{stat} \cdot 100; P_{HHP} = \frac{2}{10} \cdot F_{stat} \cdot 100 ; P_{VHHP} = \frac{2}{15} \cdot F_{stat} \cdot 100 \text{ give:}$$

$$EN_{moy} = \frac{2}{21} F_{stat} \times 100; EN_{moy} = \frac{2}{22.5} F_{stat} \times 100 ; EN_{moy} = \frac{2}{21} F_{stat} \times 100$$

which gives an average of:

$$EN_{moy} \approx 4.55 \cdot F_{tot}$$

Another method to regain this relationship is to go through the breaking load of the chain cable, with both regulatory formulas and direct calculation. This method also reveals another hypothesis of the regulatory calculation. The formula linking the static force F_{stat} and the breaking load BL of the chain cable is only valid for an ordinary steel chain cable (Q_1 steel grade) $BL = 12 \cdot F_{stat}$. For grades Q_2 and Q_3 steel, the calculation assumptions are:

$$BL = 13.5 \cdot F_{stat} \text{ for chain cable made of Q}_2 \text{ steel grades,}$$
$$BL = 15 \cdot F_{stat} \text{ for chain cable made of Q}_3 \text{ steel grades.}$$

4. CONSEQUENCE ASSESSEMENT

To assess the validity of this alternative methodology to select anchoring equipment consequence assessment has been performed on different ships of different types. Anchoring equipment has been selected on each ship with both EN number methodology and direct force calculation methodology. Results are summarized in the following graphs.

4.1. Tested ships

23 ships have been tested and selected as follow:

Estimated L _{BP}	EN		ship type							
			general cargo	tanker	passenger ship	tugboat	special ship	OSV	fishing ship	other
28	205	240				Ship 22	Ship 8			
31	240	280				Ship 23	Ship 4			
34	280	320				Ship 24				
36	320	360				Ship 25				
39	360	400								
42	400	450			Ship 5					
44	450	500								
47	500	550	Ship 19							
50	550	600			Ship 9					
52	600	660								
55	660	720			Ship 10					
57	720	780		Ship 18	Ship 17			Ship 1		
60	780	840	Ship 20							
63	840	910						Ship 26		Ship 6
65	910	980						Ship 2		
68	980	1060		Ship 21					Ship 11	Ship 3
71	1060	1140						Ship 15	Ship 14	Ship 7
74	1140	1220								
76	1220	1300					Ship 16			
79	1300	1390								
82	1390	1480						Ship 27		
84	1480	1570						Ship 12		
87	1570	1670						Ship 13		
90	1670	1790								

4.2. Anchor weight

Difference between both methodologies in terms of anchor weight is presented as follow:

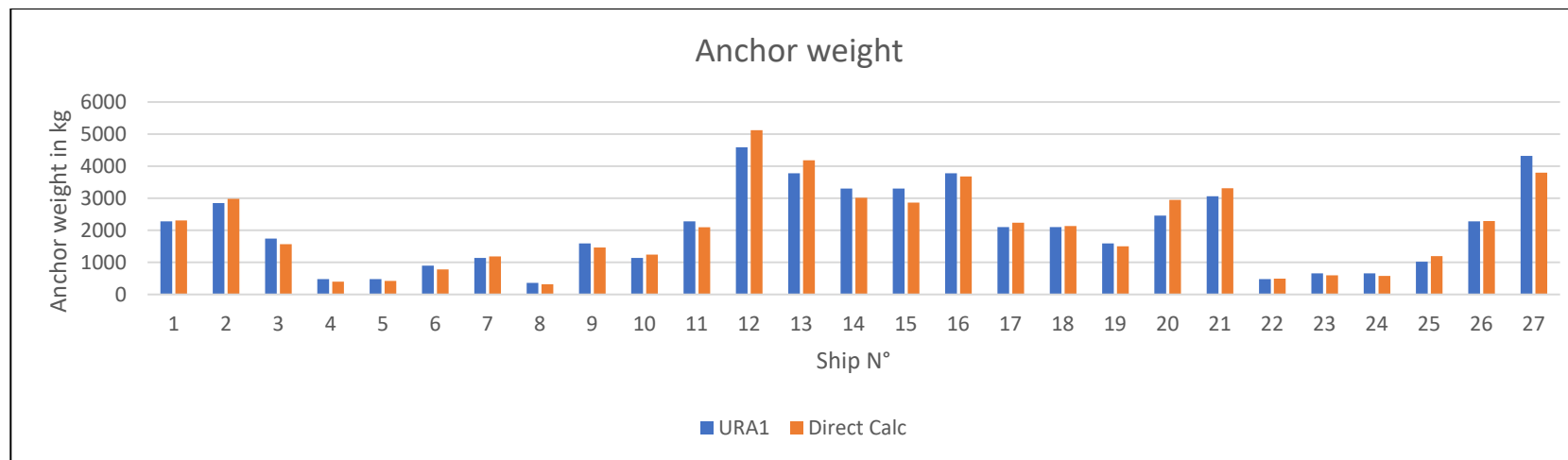

4.3. Chain length

Difference between both methodologies in terms of chain length per anchoring line is presented as follow:

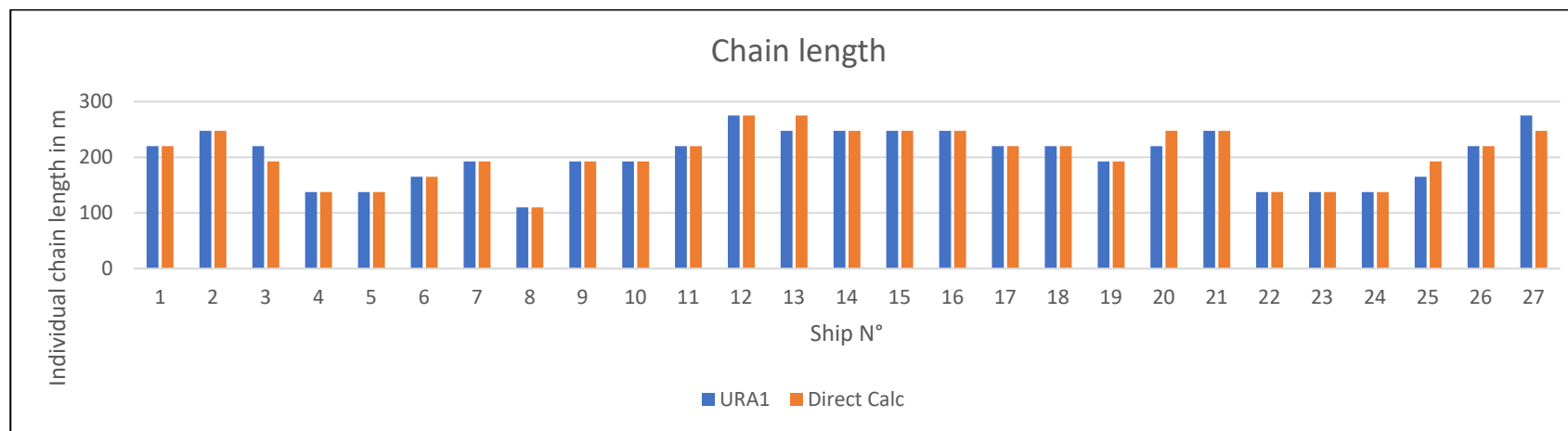

4.4. Chain diameters

Difference between both methodologies in terms of chain diameter is presented as follow:

- Chain grade Q1

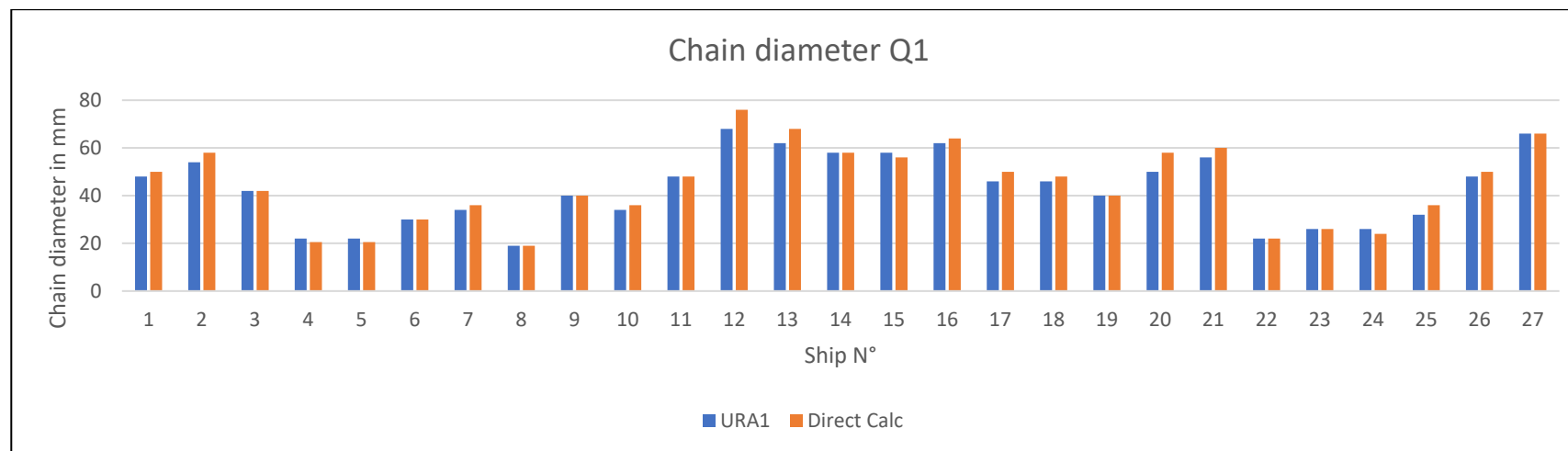

- Chain grade Q2

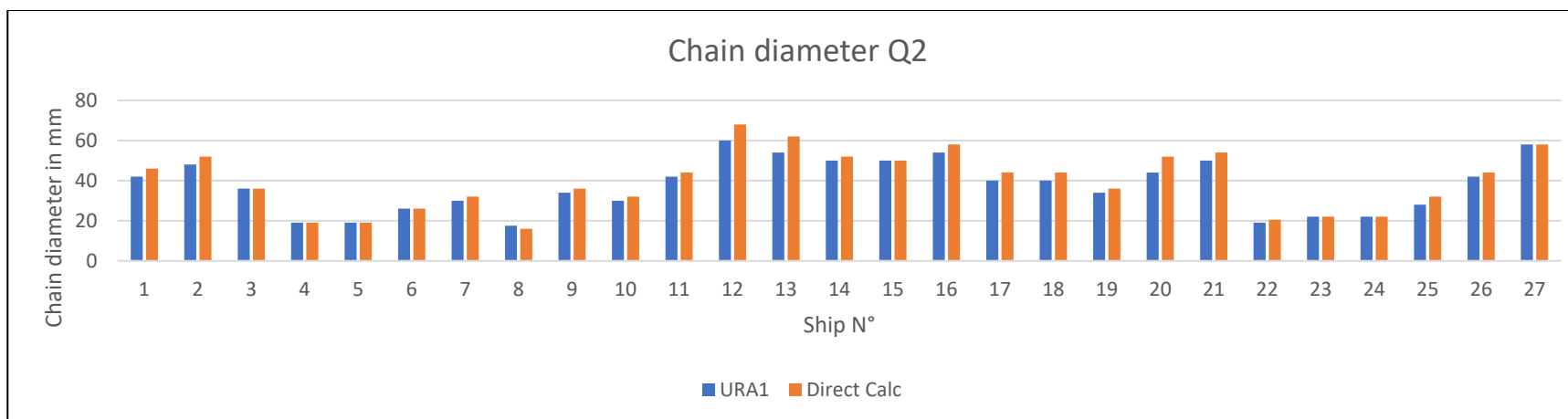

- Chain grade Q3

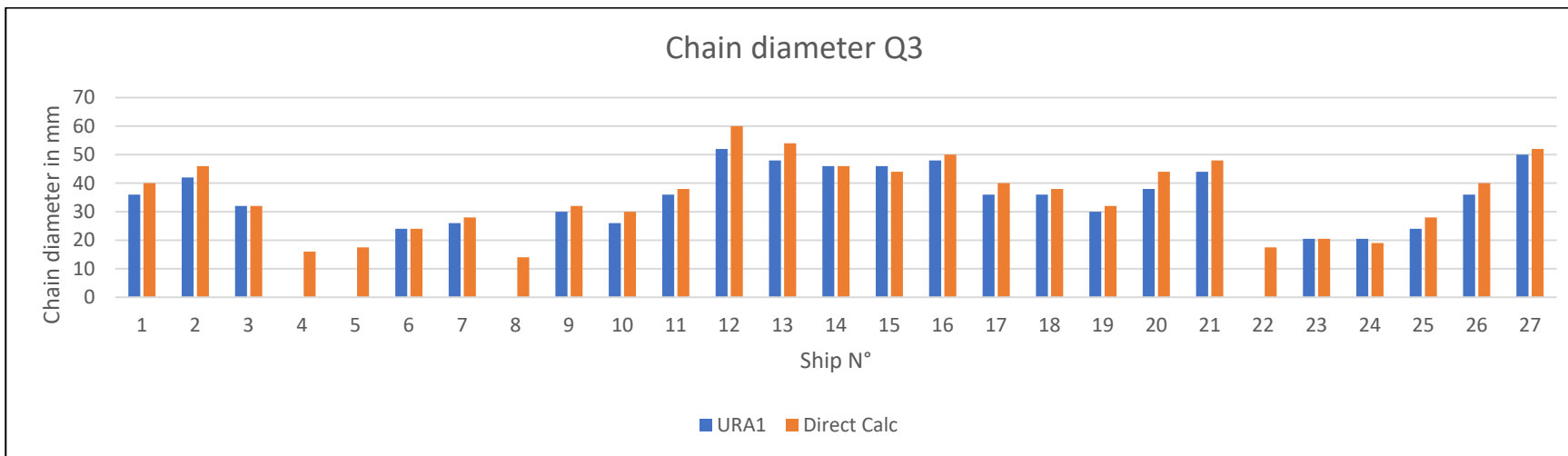

REC 11 “Materials Selection Guideline for Mobile Offshore Drilling Units”

Summary

Rev.3 of Recommendation 11 updates the materials designation for Mobile Offshore Drilling Units in accordance with the UR W11 and W16.

Part A. Revision History

Version no.	Approval date	Implementation date when applicable
Rev.3 (Oct 2019)	27 October 2019	-
Rev.2 (June 2019)	28 June 2019	-
Rev.1 (1996)	<i>No record</i>	-
NEW (1983)	<i>No record</i>	-

• Rev.3 (Oct 2019)

1 Origin of change:

- Suggestion by IACS member (GPG, Ref: 13202_IGy)

2 Main reasons for change:

GPG tasked the Hull panel to amend IACS Rec.11 and its associated HF/TB for addressing the inconsistencies in the material designation with UR W11 and W16.

3 List of non-IACS Member classification societies contributing through the TC Forum and/or participating in IACS Working Group:

None

4 History of decisions made:

The Table 1 has been updated for the designation of steel in agreement with the EG/M&W Chair.

The higher tensile steels (yield strength between 315 and 390 MPa) have been noted A32 to F40 as per W11; the high tensile steels (yield strength between 420 and 690 MPa) have been noted AH420 to FH690 as per W16.

In addition, as the Table 1 was not mentioned in the text of the Rec.11, a new paragraph 3.4 has been input for calling the Table 1. The Note in bold characters mentioned above Table 1 in the Rev.1 and Rev.2 has been moved to paragraph 3.4 for better highlighting.

5 Other Resolutions changes

None

6 Any hinderance to MASS, including any other new technologies:

None

7 Dates:

Original proposal: 12 Mar 2019 (Ref: PH16022)
Panel submission to GPG: 30 September 2019 (Ref: 13202_PHc)
GPG Approval: 27 October 2019 (Ref: 13202_IGzd)

• Rev.2 (June 2019)

1 Origin of change:

- Suggestion by IACS member (GPG)
- Based on IACS Requirement (UR W16 Rev. 3 (Mar 2016))

2 Main reasons for change:

2.1 The thickness limitations of hull structural steel in Rec 11 table 1 are provided in accordance with the requirements of UR W11 and UR W16 for various application categories and design temperatures.

2.2 The EG/M&W updated the UR W16 requirements in March 2016 to align IACS requirements with international standards for high strength steels, to unify the procedures for the approval of the manufacturer of high strength steels and considering that the manufacturing technology of steelmaking of high strength steels has advanced.

3 List of non-IACS Member classification societies contributing through the TC Forum and/or participating in IACS Working Group:

None

4 History of decisions made:

4.1 The GPG tasked the Hull Panel (13202_IGk) under the standing task for maintenance of IACS Resolutions to consider the structural design requirements of Recommendation 11 for consistency with the revised UR W16 rev.3.

4.2 The Hull Panel decided to update the Rec 11 table 1 to clarify the application of high tensile and extra high tensile steels according to the updated UR W16. Additionally the delivery conditions as per UR W16.1.3 have been referenced including the Normalized (N), Normalized rolled (NR), Thermo-mechanical controlled rolled (TM) or Quenched and Tempered (QT) conditions. These clarifications have been introduced via notes 5 to 7 in table 1.

5 Other Resolutions changes

None

6 Any hinderance to MASS, including any other new technologies:

None

7 Dates:

Original proposal: 12 March 2019 (Ref: PH16022)

Panel submission to GPG: 28 May 2019 (Ref: 13202_PHa)

GPG Approval: 28 June 2019 (Ref: 13202_IGw)

- **Rev.1 (1996)**

No TB document available.

- **NEW (1983)**

No TB document available.

Part B. Technical Background

List of Technical Background (TB) documents for Rec 11:

Note: *There are no separate Technical Background (TB) documents for the original resolution (1983), Rev.1 (1996), Rev.2 (June 2019) and Rev.3 (Oct 2019).*

Rec.13 “Standards for Ship Equipment for Mooring at Single Point Moorings”

Summary

Rec.13 is updated to point at the standard for single point mooring given in OCIMF MEG4 Section 4.3.

Part A. Revision History

<i>Version no.</i>	Approval date	Implementation date when applicable
Rev.3 (July 2020)	13 July 2020	-
Rev.2 (Dec 2019)	17 December 2019	-
Rev.1 (July 2004)	July 2004	-
New (1984)	1984	-

- **Rev.3 (July 2020)**

1 Origin of Change:

- Suggestion by IACS member

2 Main Reason for Change:

IACS Member identified that the Rec.13 does not reflect OCIMF MEG4 Section 4.3.1. The content of Rec.13 is now aligned with MEG4 Section 4.3.

3 List of non-IACS Member classification societies contributing or participating in IACS Working Group:

N/A

4 History of Decisions Made:

The Hull Panel discussed the subject via correspondence and the unanimously agreed to update the Rec.13 making reference to the “Mooring Equipment Guidelines (MEG 4)”.

5 Other Resolutions Changes:

None

6 Any hinderance to MASS, including any other new technologies:

None

7 Dates:

Original Proposal: 01 April 2020 Made by: Hull Panel
Panel Approval: 23 April 2020 (Ref: 19237_PHb)
GPG Approval: 13 July 2020 (Ref: 19237_IGg)

• Rev.2 (Dec 2019)

1 Origin of Change:

- Suggestion by IACS member

2 Main Reason for Change:

The GPG tasked the Hull Panel under the standing task for maintenance of IACS Resolutions to identify the ones needing update among the resolutions and recommendations which have not been updated for the last ten years.

IACS Member identified that the Rec.13 refers to a previous version of the OCIMF "Standard for Equipment Employed in the Mooring of Ships at Single Point Moorings". This OCIMF document has been withdrawn and the content related to equipment for single point mooring is now included in MEG4 Section 4.3.

3 List of non-IACS Member classification societies contributing through the TC Forum and/or participating in IACS Working Group:

N/A

4 History of Decisions Made:

The Hull Panel discussed the subject via correspondence and the qualified majority agreed to update the Rec.13 making reference to the "Mooring Equipment Guidelines (MEG 4)".

5 Other Resolutions Changes:

None

6 Any hinderance to MASS, including any other new technologies:

None

7 Dates:

Original Proposal: 09 May 2019 Made by: Hull Panel
Panel Approval: 29 November 2019 (Ref: 19237_PHa)
GPG Approval: 17 December 2019 (Ref: 19237_IGb)

- **Rev.1 (July 2004)**

No TB document available.

- **New (1984)**

No TB document available.

Part B. Technical Background

List of Technical Background (TB) documents for Rec. 13:

Note: *There are no separate Technical Background (TB) documents for the original version (1984), Rev.1 (July 2004), Rev.2 (Dec 2019) and Rev.3 (July 2020).*



Recommendation No. 15

"Care and Survey of hatch covers of dry cargo ships- Guidance to owners-"

Part A. Revision History

Version no.	Approval date	Implementation date when applicable
Rev.3 (Aug 2013)	21 August 2013	-
Rev.2 (1997)	11 September 1997	-
Rev.1 (1989)	<i>No records</i>	-
Rev.0 (1986)	<i>No records</i>	-

• Rev.3 (Aug 2013)

.1 Origin of Change:

- Suggestion by IACS Members

.2 Main Reason for Change:

- UR Z4 was deleted in May 2013 as the requirements in UR Z4 were already incorporated in UR Z7.
- During reviewing the deletion of UR Z4, GPG Member proposed to consider the revision of Recommendation 15 since the entire text of UR Z4 was reproduced and contained in Annex of Recommendation 15.
- Tasked by GPG, Survey Panel further reviewed and deleted the reference of UR Z4 from the Recommendation 15.

.3 List of non-IACS Member classification societies contributing through the TC Forum and/or participating in IACS Working Group:

None

.4 History of Decisions Made:

Completed through mail correspondence.

.5 Other Resolutions Changes

None

.6 Dates:

Original Proposal: 22 May 2013 (9640_IGn) Made by: GPG
Panel Approval: 9 July 2013 by Survey Panel (ref. PSU13018)
GPG Approval: 21 August 2013 (Ref: 9640_IGp)

- **Rev.2 (1997)**

The existing "Annex to Care and Survey of hatch covers of dry cargo ships- Guidance to owners- IACS Requirement Z4" is replaced with current revision i.e. UR Z4 (Rev.2 1996, V2.1).

- **Rev.1 (1989)**

No records available.

- **Rev.0 (1985)**

No records available.

Part B. Technical Background

No Technical Background (TB) documents have been prepared for Rev.0 (1985), Rev.1 (1989), Rev.2 (1996) and Rev.3 (Aug 2013).



Recommendation No.17 - "Guidelines for the Acceptance of Manufacturer's Quality Assurance Systems for Welding Consumables"

Summary

A review of the current revision, last completed 1987, found that it was still relevant however it required updating to reflect the latest revisions of UR W17 & W23, align with the philosophy of UR Z26 and to update terminology in line with current standards.

Part A. Revision History

Version no.	Approval date	Implementation date when applicable
Rev.1 (Mar 2020)	17 March 2020	-
New (1987)	1987	-

• Rev. 1 (Mar 2020)

1 Origin of Change:

- Suggestion by IACS member

2 Main Reason for Change:

To update the recommendation to align with current IAC's UR's, International Standards and philosophies, and modern language style.

3 List of non-IACS Member classification societies contributing through the TC Forum and/or participating in IACS Working Group:

None

4 History of Decisions Made:

1. A working group review was completed, and IACS Rec 17 was considered to be relevant to the Marine industry, but required updating.

The first draft produced incorporating the results of the review.

2. Comments received from members and 2nd draft produced:
 - a. agreed to exclude welding consumable approval grades Y89 and Y96
 - b. keep maximum approval length to 5 years
 - c. further grammar changes to reflect more appropriate language and to reflect terminology with respect to ISO 9000 standards

3. upon consideration by GPG, the procedure for adoption of the document is provided in the relevant text

5 Other Resolutions Changes:

None

6 Any hinderance to MASS, including any other new technologies:

none

7 Dates:

Original Proposal: Q4 2018 Made by: EG M&W
WG Approval: 11 February 2020 (Ref: 18220_EMWc)
GPG Approval: 17 March 2020 (Ref: 18220_IGf)

- **New (1987)**

No history files or TB document available.

Part B. Technical Background

List of Technical Background (TB) documents:

Annex 1. **TB for Rev.1 (Mar 2020)**

See separate TB document in Annex 1.

1) There is no separate Technical Background (TB) document for New (1987).

Technical Background (TB) document for Rec 17 (Rev.1 Mar 2020)

1. Scope and objectives

This recommendation describes an alternative scheme for the maintenance of approval of welding consumables for use in shipbuilding where the witnessing of welding and testing of assemblies (direct survey) is delegated to the manufacture on the basis of the acceptance of their quality assurance system.

By acceptance of their quality assurance system, the manufacturer is obligated to comply with the requirements of the Classification Society Rules, and the general principles as laid down in IACS Recommendation 17.

2. Engineering background for technical basis and rationale

This recommendation was originally published in 1987, however, since then until now (2019), no review or further revisions have been completed. Therefore members agreed that a review was required to assess if it was still relevant, and to ascertain if a suitable equivalent level of assurance is provided with respect to UR W17 and W23. Furthermore, to determine the alignment with the philosophy of UR Z26, which allows manufacturers to perform the required inspection and testing without the presence of a Surveyor.

It was determined from the review that:

- Standards referenced were obsolete and needed replacing with current revisions (and their relevant version number and year)
- Definitions needed to align with ISO 9000:2015
- The recommendation should align with ISO 9001:2015 for quality assurance and management approach.
- The recommendation should align with UR Z26 where applicable.

As a result of the review, the working group was tasked with revising the current recommendation.

3. Source/derivation of the proposed IACS Resolution

- UR W17 Approval of consumables for welding normal and higher strength hull structural steels - Rev.5
- UR W23 Approval of Welding Consumables for High Strength Steels for Welded Structures – Corr.1
- UR Z26 Alternative Certification Scheme (ACS) - Feb 2015
- ISO 9000:2015 Quality management systems — Fundamentals and vocabulary
- ISO 9001:2015 Quality management systems — Requirements

4. Summary of Changes intended for the revised Resolution:

- Alignment with UR Z26 where applicable
- Referenced to UR W23 included (which did not exist in the original version)
- Updated language style
- Update references to quality management systems

Update status of document

5. Points of discussions or possible discussions

a) Paragraph 1.1.1, grades Y89 and Y96 excluded from approval using this alternative scheme (whilst these grades are new and consumables are under development by industry, considered that direct survey approach only was more suitable)

b) Paragraph 1.6.1, maximum approval length kept at 5 years

6. Attachments if any

n/a

Recommendation No.18 “Fire Prevention in Machinery Spaces of Ships in Service – Guidance to Owners”

Summary

This Original Recommendation provides a Guidance to Owners fire prevention in Machinery Spaces of Ships in Service.

Part of this recommendation reflected in SOLAS so partially deleted some outdated narration.

Part A. Revision History

Version no.	Approval date	Implementation date when applicable
Rev.2 (Feb 2021)	04 February 2021	-
Rev.1 (June 1999)	June 1999	-
New (1987)	1987	-

• Rev.2 (Feb 2021)

1 Origin of Change:

Select a relevant option and delete the rest.

- Based on IACS Requirement (Periodic review of IACS Resolution by Safety Panel)

2 Main Reason for Change:

Minor editorial amendments relating to the reference to kind of surveys was made and references to Rec. No.58 and MSC.1/Circ.1321 were added.

3 List of non-IACS Member classification societies contributing or participating in IACS Working Group:

None

4 History of Decisions Made:

Based on periodic review of IACS Resolution by Safety Panel, this document rather outdated. The Safety Panel agreed to update this recommendation.

5 Other Resolutions Changes:

None

6 Any hinderance to MASS, including any other new technologies:

Not applicable.

7 Dates:

Original Proposal:	December 2020 (Made by Safety Panel)
Panel Approval:	18 January 2021 (Ref: PS19002mISb)
GPG Approval:	04 February 2021 (Ref: 19001gIGb)

- **Rev.1 (June 1999)**

No records available.

- **New (1987)**

No records available.

Part B. Technical Background

List of Technical Background (TB) documents:

Annex 1 **TB for Rev.2 (Feb 2021)**

See separate TB document in Annex 1.



Note: There are no separate Technical Background (TB) documents for New (1987) and Rev.1 (1999).

Technical Background (TB) document for Rec 18 (Rev.2 Feb 2021)

1. Scope and objectives

Review of the IACS Recommendation No.18 Rev.1 (June 1999)

2. Engineering background for technical basis and rationale

Chapter II-2/Reg.4 of the current SOLAS covers reducing the probability of fire ignition caused by oil leaks in engine rooms. The following safety measures became mandatory SOLAS requirement for all ships from July 2003;

- 1) Jacketed piping system in high pressure fuel oil lines (SOLAS II-2/Reg.4 2.2.5.2) ;
- 2) Protection of high temperature surfaces exceeding 220°C (SOLAS II-2/Reg.4 2.2.6);
- 3) Locational limitation for oil fuel lines. These pipes shall not be located immediately above or near units of high temperature including boilers, steam pipelines, exhaust manifolds, silencers or other equipment required to be insulated by SOLAS regulation Reg.4 2.2.6 (SOLAS II-2/Reg.4 2.2.5.3).
- 4) Restriction of using flexible pipes. Upon the satisfaction of Flag Administration, flexible pipes shall be permissible. Reference shown on footnote of ISO standards 15540 and 15541 'Test methods for fire resistance of hose assemblies' and 'Fire resistance of hose assemblies' each.(SOLAS II-2/Reg.4 2.2.5.1)

The major concerned potential fire hazards dealing this recommendation are reflected into the current SOLAS.

3. Source/derivation of the proposed IACS Resolution

Not applicable

4. Summary of Changes intended for the revised Resolution:

Updated cross references of code.

5. Points of discussions or possible discussions

Safety panel unanimously agreed to update this outdated document.

6. Attachments if any

None

Recommendation No.21 “Guidelines on approval procedure for onboard loading computers”

Summary

Recommendation No.21 was deleted, taking into account the presence of a relative IACS document (Recommendation No.48).

Part A. Revision History

Version no.	Approval date	Implementation date when applicable
Del (Mar 2021)	18 March 2021	-
Rev.1 (Sept 2005)	Sept 2005	-
New (1988)	1988	-

- **Del (Mar 2021)**

1 Origin of Change:

- Other (Periodical review carried out by Machinery Panel)

2 Main Reason for Change:

Recommendation No.21 was deleted, taking into account the presence of a relative IACS document (Recommendation No.48).

3 List of non-IACS Member classification societies contributing or participating in IACS Working Group:

None

4 History of Decisions Made:

None

5 Other Resolutions Changes:

None

6 Any hinderance to MASS, including any other new technologies:

None

7 Dates:

Original Proposal: 28 October 2019 (Ref: PM18939_IMd)
Panel Approval: 9 November 2020 (Ref: PM20906_IMf)
GPG Approval: 18 March 2021 (Ref: 20206clGd)

- **Rev. 1 (Sep 2005)**

No history files or TB document available.

- **New (1988)**

No history files or TB document available.

Part B. Technical Background

List of Technical Background (TB) documents for Recommendation No. 21:



Note: *There are no Technical Background (TB) documents available for the New (1988), Rev.1 (Sept 2005) and Del (Mar 2021).*

Recommendation No. 24 “Intact Stability”

Summary

Recommendation 24 provides recommendations on values to be used in context of UR L2 intact stability assessment of ships with a length of 24 m and above. This revision considers changes with respect to the amendments to MSC.267(85) Intact Stability Code.

Part A. Revision History

Version no.	Approval date	Implementation date when applicable
Rev.7 (Nov 2023)	24 November 2023	-
Rev.6 (July 2013)	23 July 2013	-
Rev.5 (May 2004)	<i>No records</i>	-
Rev.4 (June 2002)	5 June 2002	-
Rev.3 (June 2000)	15 June 2000	-
Rev.2 (1994)	<i>No records</i>	-
Rev.1 (1989)	<i>No records</i>	-
New (1988)	<i>No records</i>	-

• Rev.7 (Nov 2023)

1 Origin:

- Based on IACS Requirement (Periodic review of IACS Resolutions)

2 Main Reason for Change:

Since 2013 IMO approved several amendments to the 2008 Intact Stability Code (MSC 267(85)).

3 List of non-IACS Member classification societies contributing through the TC Forum and/or participating in IACS Working Group:

None

4 History of Decisions Made:

The Recommendation 24 of 2013 was updated with respect to the amendments made to 2008 INTACT Stability Code.

Discussed by correspondence in the Safety Panel.

5 Other Resolutions Changes:

None

6 Any hinderance to MASS, including any other new technologies:

None

7 Dates:

Panel Approval:	09 November 2023	(Ref: PS23036cISf)
GPG Approval:	24 November 2023	(Ref: 22183hIGb)

• Rev.6 (July 2013)

.1 Origin:

Suggestion by IACS Statutory Panel

.2 Main Reason for Change:

Recommendation was revised by the Statutory Panel in the light of the entering into force of the New Intact Stability Code (MSC 267(85)).

.3 List of non-IACS Member classification societies contributing through the TC Forum and/or participating in IACS Working Group:

None

.4 History of Decisions Made:

IACS Rec.24 (Rev.6) initially developed by PT 30 and then finalized by the Statutory Panel under Task 36 - Maintenance of IACS Resolutions - UR L5, UR L2 and Rec.24. The revised Recommendation has been unanimously agreed by the Panel.

.5 Other Resolutions Changes:

None

.6 Dates:

Panel Approval: 27 June 2013 by Statutory Panel (Ref: SP11016c)
GPG Approval: 23 July 2013 (Ref: 11160_IGh)

• Rev.5 (May 2004)

Revision submitted to GPG56. No other records available.

• Rev.4 (June 2002)

Outcome of WP/SSLL Task 6. Revision submitted to GPG52.
No other records available.

- **Rev.3 (June 2000)**

Amends references to IMO stability criteria. Revision submitted to GPG48.
No other records available

- **Rev.2 (1994)**

No records available

- **Rev.1 (1989)**

No records available

- **Original resolution (1988)**

No records available

Part B. Technical Background

Annex 1. TB for Rev.7 (Nov 2023)

See separate TB document in Annex 1.

Note: *No separate Technical Background (TB) documents are available for Rec.24 versions Original 1988, Rev.1 1989, Rev.2 1994, Rev.3 June 2000, Rev.4 June 2002, Rev.5 May 2004 and Rev.6 July 2013.*

Technical Background (TB) document for Recommendation No. 24 "Intact Stability" (Rev.7 Nov 2023)

1. Scope and objectives

N/A

2. Engineering background for technical basis and rationale

N/A

2a. Specification of the data utilised in the development/revision of the proposed IACS Resolution, if any

N/A

3. Source/derivation of the proposed IACS Resolution

N/A

4. Summary of Changes intended for the revised Resolution:

- Updating the reference to IS Code by "as amended"
- Amending in section "for towing vessels ..."
- Deleting all recommendations provided under "additional"

5. Points of discussions or possible discussions

Safety Panel reviewed Rec.24 with respect to the need considering the amendments to MSC.267(85) Intact Stability Code which are

- RESOLUTION MSC.319(89), adopted on 20 May 2011
- RESOLUTION MSC.398(95), adopted on 5 June 2015
- RESOLUTION MSC.414(97), adopted on 25 November 2016
- RESOLUTION MSC.415(97), adopted on 25 November 2016
- RESOLUTION MSC.444(99), adopted on 24 May 2018

Noticing the relation between this recommendation and UR L2, both documents were reviewed together and potential amendments discussed.

The Panel agreed to consider the IMO resolutions listed above by introducing "as amended" when referencing to MSC.267(85).

By IMO Res.415(97) IS Code was amended by section 2.8 Ships engaged in towing and escort operations, and the Panel agreed that the recommendations provided under "additional" and not required anymore and agreed to delete them.

6. Attachments if any

No attachments

Recommendation No.26 “Spare parts for main internal combustion engines of ships for unrestricted service”

Summary

Prior to this latest revision, Recommendation No. 26 Rev.1 detailed the minimum spare parts to be carried onboard for main engines for unrestricted service applications. Following feedback from industry suggesting that the detailed list was out of date, the Recommendation has been revised in Rev.2 to recommend a risk-based approach to determination of the minimum spare parts to be carried onboard. The detailed list is retained as an example only.

Part A. Revision History

Version no.	Approval date	Implementation date when applicable
Rev.2 (Nov 2023)	16 November 2023	-
Rev.1 (Nov 2006)	November 2006	-
New (1990)	1990	-

• Rev.2 (Nov 2023)

1 Origin of Change:

- Request by non-IACS entity (MARTECMA)

2 Main Reason for Change:

In a communication with IACS GPG concerning IACS Recommendation Nos. 26 to 30, according to MARTECMA “*The lists have been produced a long time ago under an obsolete technological environment*” i.e. they need updating to take account of current technology and the associated spares required.

3 List of non-IACS Member classification societies contributing or participating in IACS Working Group:

CIMAC – International Council on Combustion Engines
MARTECMA – Marine Technical Managers Association.

4 History of Decisions Made:

GPG requested that the Machinery Panel consider the communication received from MARTECMA suggesting that Recommendations 26-30 required updating. The majority of Machinery Panel members agreed on the need for a revision of the Recommendations. Four members preferred that the Recommendations be withdrawn.

Given the subject matter of the Recommendations, Machinery Panel members agreed to seek proposals for the revision from both CIMAC and MARTECMA. Form A was prepared which included cooperation with industry including CIMAC and MARTECMA. Information was received back from MAN ES via CIMAC and from MARTECMA as a consequence.

5 Other Resolutions Changes:

None.

6 Any hinderance to MASS, including any other new technologies:

None.

7 Dates:

Original Proposal:	18 September 2020	(Ref: PM20926_LRk)
Panel Approval:	23 October 2023	(Ref: PM20926IMz)
GPG Approval:	16 November 2023	(Ref: 20145_IGn)

• **Rev.1 (Nov 2006)**

No history file or TB document available.

• **New (1990)**

No history file or TB document available.

Part B. Technical Background

List of Technical Background (TB) documents for Recommendation No.26:

Annex 1. **TB for Rev.2 (Nov 2023)**

See separate TB document in Annex 1.

Note: *There are no separate Technical Background (TB) documents available for New (1990) and Rev.1 (Nov 2006).*

Technical Background (TB) document for Rec. 26 (Rev.2 Nov 2023)

1. Scope and objectives

IACS Recommendation No. 26 provides a detailed list of recommended spare parts to be carried onboard for ships trading internationally. While the availability of spare parts onboard is considered by IACS members to be a matter for individual IACS members, who may or may not incorporate details within their Rules and Regulations, in response to industry feedback suggesting Rec. 26, last revised in 2006, was out of date and no longer reflected the design of modern engines, IACS members agreed revision was appropriate resulting in the publication of Rev.2.

2. Engineering background for technical basis and rationale

While the feedback from industry indicated a preference for IACS to publish a detailed, prescriptive list of spare parts to be carried onboard, in recognition of the increasing rate at which new, highly complex technologies were being developed and deployed onboard ships, Machinery Panel members agreed that a prescriptive approach was no longer tenable, and a risk-based approach, realised through the application of risk assessment techniques, was appropriate. It was agreed to retain the detailed prescriptive list from Rev. 1 Rec. 26 as an example only.

2a. Specification of the data utilised in the development/revision of the proposed IACS Recommendation, if any

None.

3. Source/derivation of the proposed IACS Recommendation

Derivation of the revised Recommendation is based on practical knowledge of IACS members in the application of risk assessment techniques informed by comments from MARTECMA and CIMAC.

4. Summary of Changes intended for the revised IACS Recommendation:

The list of spare parts recommended to be carried onboard for main engines in Rev.1 is retained in Rev.2 but is changed to an example of spare parts recommended to be carried onboard with additional text indicating that the example is relevant to conventionally fuelled engines only i.e. oil fuelled. This example becomes Section 3. Two new earlier sections are introduced into the Recommendation, an introduction describing the objective and scope of the Recommendation in Section 1 and the risk-based approach recommended for the determination of spare parts to be carried onboard in Section 2. The marked-up version of Rev.2 is attached.

5. Points of discussions or possible discussions

Draft Rev.2 Recommendation was initiated by comments received from MARTECMA, extensively discussed by Machinery Panel members and reviewed by IACS GPG during development and finally reviewed by CIMAC members with particular points of discussion or comments received as indicated below.

Inclusion of engine automation within the scope of the Recommendation as a result of MARTECMA comments. Section 1, Para 4 added to clarify scope.

Clarification that the Recommendation applies to main internal combustion engines irrespective of the configuration of the propulsion system as a result of CIMAC feedback. Section 1, Para 4 updated accordingly.

The different approach to spare parts between IACS members as a result of GPG feedback. Section 1, Para 5 added to clarify that the implementation of the Recommendation is a matter for individual Societies.

The inclusion of recommended spare parts list in documentation submitted for Type Approval as a result of MARTECMA comments. Section 2.2, Para 4 added accordingly.

Clarification that at least one spare part or set of spare parts should be supplied unless the risk assessment concludes otherwise as a result of CIMAC feedback. Section 2.3, Para 1 and Para 2 updated accordingly.

The certification of spare parts. Section 2.3 Para 3 added to clarify.

Item 16 in Table 1 (Control, alarm and safety system) added as a result of CIMAC feedback.

6. Attachments if any

Marked-up version of Rev.2 is attached

Recommendation No.27 “List of minimum recommended spare parts for each type of auxiliary internal combustion engine driving electric generators for essential services on board ships for unrestricted service”

Summary

Prior to this latest revision, Recommendation No.27 Rev.1 detailed the minimum spare parts to be carried onboard for auxiliary internal combustion engines driving electric generators for essential services on board ships for unrestricted service applications. Following feedback from industry suggesting that the IACS Recommendations for spare parts are out of date, with particular mention of Rec.26 for main engine spares, all of the Recommendations related to spare parts have been revised in Rev.2 to recommend a risk-based approach to determination of the minimum spare parts to be carried onboard and the detailed lists of spare parts are retained as examples only.

Part A. Revision History

Version no.	Approval date	Implementation date when applicable
Rev.2 (Feb 2024)	29 February 2024	-
Rev.1	Nov 2006	-
New	1990	-

• Rev.2 (Feb 2024)

1 Origin of Change:

- Request by non-IACS entity (MARTECMA)

2 Main Reason for Change:

In a communication with IACS GPG concerning IACS Recommendation Nos. 26 to 30, according to MARTECMA “*The lists have been produced a long time ago under an obsolete technological environment*” i.e. they need updating to take account of current technology and the associated spares required.

3 List of non-IACS Member classification societies contributing or participating in IACS Working Group:

CIMAC – International Council on Combustion Engines
MARTECMA – Marine Technical Managers Association.

4 History of Decisions Made:

GPG requested that the Machinery Panel consider the communication received from MARTECMA suggesting that Recommendations 26 to 30 required updating. The majority of Machinery Panel members agreed on the need for a revision of the Recommendations. Four members preferred that the Recommendations be withdrawn.

Given the subject matter of the Recommendations, Machinery Panel members agreed to seek proposals for the revision from both CIMAC and MARTECMA. Form A was prepared which included cooperation with industry including CIMAC and MARTECMA. Information was received back from MAN ES via CIMAC and from MARTECMA as a consequence.

5 Other Resolutions Changes:

None.

6 Any hinderance to MASS, including any other new technologies:

None.

7 Dates:

Original Proposal:	18 September 2020	(Ref: PM20926_LRk)
Panel Approval:	23 October 2023	(Ref: PM20926IMz)
GPG Approval:	29 February 2024	(Ref: 20145_IGp)

- **Rev.1 (Nov 2006)**

No history file or TB document available.

- **New (1990)**

No history file or TB document available.

Part B. Technical Background

List of Technical Background (TB) documents for Recommendation No.27:

Annex 1. TB for Rev.2 (Feb 2024)

See separate TB document in Annex 1.

Note: There are no separate Technical Background (TB) documents available for New (1990) and Rev.1 (June 2006).

Technical Background (TB) document for Rec.27 (Rev.2 Feb 2024)

1. Scope and objectives

IACS Recommendation No.27 provides a detailed list of recommended spare parts to be carried onboard for ships trading internationally. While the availability of spare parts onboard is considered by IACS members to be a matter for individual IACS members, who may or may not incorporate details within their Rules and Regulations, in response to industry feedback suggesting the IACS Recommendations for spare parts, in particular Rec.26, were out of date and no longer reflected the design of modern engines and other essential machinery and equipment, IACS members agreed revision was appropriate resulting in the publication of Rev.2 for each of the Recommendations.

2. Engineering background for technical basis and rationale

While the feedback from industry indicated a preference for IACS to publish a detailed, prescriptive list of spare parts to be carried onboard, in recognition of the increasing rate at which new, highly complex technologies were being developed and deployed onboard ships, Machinery Panel members agreed that a prescriptive approach was no longer tenable, and a risk-based approach, realised through the application of risk assessment techniques, was appropriate. It was agreed to retain the detailed prescriptive lists from Rev. 1 of the Recommendations as examples only.

2a. Specification of the data utilised in the development/revision of the proposed IACS Recommendation, if any

None.

3. Source/derivation of the proposed IACS Recommendation

Derivation of the revised Recommendation is based on practical knowledge of IACS members in the application of risk assessment techniques informed by comments from MARTECMA and CIMAC.

4. Summary of Changes intended for the revised IACS Recommendation:

The list of spare parts recommended to be carried onboard in Rev.1 of Rec.27 is retained in Rev.2 but is changed to an example of spare parts recommended to be carried onboard. This example becomes Section 2. A new Section 1. is introduced into the Recommendation describing the need for a risk-based approach for the determination of spare parts to be carried onboard and makes cross-reference to Rec. 26. for the risk-based approach recommended to be followed, since it is the same for each of the recommendations, rather than repeating the text.

5. Points of discussions or possible discussions

Draft Rev.2 Recommendation was initiated by comments received from MARTECMA focused particularly on Rec.26. The comments were extensively discussed by Machinery Panel members and are detailed in the HF+TB for Rec.26.

The additional discussion in the Machinery Panel related specifically to Recommendations 27 to 30 was regarding the proposal to follow the same risk base approach as described in Rec.26 and if so, to make cross-reference to Rec.26 rather

than reproducing the same text in each of the Recommendations 27 to 30, both of which were agreed.

Further, the changes made to the detailed list in Rev.2 of Rec.26 were also agreed for incorporation into the detailed lists in Recommendations 27 to 30.

Draft of REC reviewed by **SuP** and **CIMAC** without comments.

6. Attachments if any

None

Recommendation No.28 “List of minimum recommended spare parts for auxiliary steam turbines driving electric generators for essential services of ships for unrestricted service”

Summary

Prior to this latest revision, Recommendation No.28 Rev.1 detailed the minimum spare parts to be carried onboard for auxiliary steam turbines driving electric generators for essential services of ships for unrestricted service unrestricted service applications. Following feedback from industry suggesting that the IACS Recommendations for spare parts are out of date, with particular mention of Rec.26 for main engine spares, all of the Recommendations related to spare parts have been revised in Rev.2 to recommend a risk-based approach to determination of the minimum spare parts to be carried onboard and the detailed lists of spare parts are retained as examples only.

Part A. Revision History

Version no.	Approval date	Implementation date when applicable
Rev.2 (Feb 2024)	29 February 2024	-
Rev.1	Nov 2006	-
New	1990	-

• Rev.2 (Feb 2024)

1 Origin of Change:

- Request by non-IACS entity (MARTECMA)

2 Main Reason for Change:

In a communication with IACS GPG concerning IACS Recommendation Nos. 26 to 30, according to MARTECMA “*The lists have been produced a long time ago under an obsolete technological environment*” i.e. they need updating to take account of current technology and the associated spares required.

3 List of non-IACS Member classification societies contributing or participating in IACS Working Group:

CIMAC – International Council on Combustion Engines
MARTECMA – Marine Technical Managers Association.

4 History of Decisions Made:

GPG requested that the Machinery Panel consider the communication received from MARTECMA suggesting that Recommendations 26 to 30 required updating. The majority of Machinery Panel members agreed on the need for a revision of the Recommendations. Four members preferred that the Recommendations be withdrawn.

Given the subject matter of the Recommendations, Machinery Panel members agreed to seek proposals for the revision from both CIMAC and MARTECMA. Form A was prepared which included cooperation with industry including CIMAC and MARTECMA. Information was received back from MAN ES via CIMAC and from MARTECMA as a consequence.

5 Other Resolutions Changes:

None.

6 Any hinderance to MASS, including any other new technologies:

None.

7 Dates:

Original Proposal:	18 September 2020	(Ref: PM20926_LRk)
Panel Approval:	23 October 2023	(Ref: PM20926IMz)
GPG Approval:	29 February 2024	(Ref: 20145_IGp)

- **Rev.1 (Nov 2006)**

No history file or TB document available.

- **New (1990)**

No history file or TB document available.

Part B. Technical Background

List of Technical Background (TB) documents for Recommendation No. 28:

Annex 1. **TB for Rev.2 (Feb 2024)**

See separate TB document in Annex 1.

Note: There are no separate Technical Background (TB) documents available for New (1990) and Rev.1 (June 2006).

Technical Background (TB) document for Rec.28 (Rev.2 Feb 2024)

1. Scope and objectives

IACS Recommendation No.28 provides a detailed list of recommended spare parts to be carried onboard for ships trading internationally. While the availability of spare parts onboard is considered by IACS members to be a matter for individual IACS members, who may or may not incorporate details within their Rules and Regulations, in response to industry feedback suggesting the IACS Recommendations for spare parts, in particular Rec.26, were out of date and no longer reflected the design of modern engines and other essential machinery and equipment, IACS members agreed revision was appropriate resulting in the publication of Rev.2 for each of the Recommendations.

2. Engineering background for technical basis and rationale

While the feedback from industry indicated a preference for IACS to publish a detailed, prescriptive list of spare parts to be carried onboard, in recognition of the increasing rate at which new, highly complex technologies were being developed and deployed onboard ships, Machinery Panel members agreed that a prescriptive approach was no longer tenable, and a risk-based approach, realised through the application of risk assessment techniques, was appropriate. It was agreed to retain the detailed prescriptive lists from Rev.1 of the Recommendations as examples only.

2a. Specification of the data utilised in the development/revision of the proposed IACS Recommendation, if any

None.

3. Source/derivation of the proposed IACS Recommendation

Derivation of the revised Recommendation is based on practical knowledge of IACS members in the application of risk assessment techniques informed by comments from MARTECMA and CIMAC.

4. Summary of Changes intended for the revised IACS Recommendation:

The list of spare parts recommended to be carried onboard in Rev.1 of Rec.28 is retained in Rev.2 but is changed to an example of spare parts recommended to be carried onboard. This example becomes Section 2. A new Section 1. is introduced into the Recommendation describing the need for a risk-based approach for the determination of spare parts to be carried onboard and makes cross-reference to Rec.26 for the risk-based approach recommended to be followed, since it is the same for each of the recommendations, rather than repeating the text.

5. Points of discussions or possible discussions

Draft Rev.2 Recommendation was initiated by comments received from MARTECMA focused particularly on Rec.26. The comments were extensively discussed by Machinery Panel members and are detailed in the HF+TB for Rec.26.

The additional discussion in the Machinery Panel related specifically to Recommendations 27 to 30 was regarding the proposal to follow the same risk base approach as described in Rec.26 and if so, to make cross-reference to Rec.26 rather

than reproducing the same text in each of the Recommendations 27 to 30, both of which were agreed.

Further, the changes made to the detailed list in Rev.2 of Rec.26 were also agreed for incorporation into the detailed lists in Recommendations 27 to 30.

Draft of REC reviewed by **SuP** and **CIMAC** without comments.

6. Attachments if any

None

Recommendation No.29 “List of minimum recommended spare parts for main steam turbines of ships for unrestricted service”

Summary

Prior to this latest revision, Recommendation No.29 Rev.1 detailed the minimum spare parts to be carried onboard for main steam turbines of ships for unrestricted service. Following feedback from industry suggesting that the IACS Recommendations for spare parts are out of date, with particular mention of Rec.26 for main engine spares, all of the Recommendations related to spare parts have been revised in Rev.2 to recommend a risk-based approach to determination of the minimum spare parts to be carried onboard and the detailed lists of spare parts are retained as examples only.

Part A. Revision History

Version no.	Approval date	Implementation date when applicable
Rev.2 (Feb 2024)	29 February 2024	-
Rev.1	Nov 2006	-
New	1990	-

• Rev.2 (Feb 2024)

1 Origin of Change:

- Request by non-IACS entity (MARTECMA)

2 Main Reason for Change:

In a communication with IACS GPG concerning IACS Recommendation Nos. 26 to 30, according to MARTECMA “*The lists have been produced a long time ago under an obsolete technological environment*” i.e. they need updating to take account of current technology and the associated spares required.

3 List of non-IACS Member classification societies contributing or participating in IACS Working Group:

CIMAC – International Council on Combustion Engines

MARTECMA – Marine Technical Managers Association.

4 History of Decisions Made:

GPG requested that the Machinery Panel consider the communication received from MARTECMA suggesting that Recommendations 26 to 30 required updating. The majority of Machinery Panel members agreed on the need for a revision of the Recommendations. Four members preferred that the Recommendations be withdrawn.

Given the subject matter of the Recommendations, Machinery Panel members agreed to seek proposals for the revision from both CIMAC and MARTECMA. Form A was prepared which included cooperation with industry including CIMAC and MARTECMA. Information was received back from MAN ES via CIMAC and from MARTECMA as a consequence.

5 Other Resolutions Changes:

None.

6 Any hinderance to MASS, including any other new technologies:

None.

7 Dates:

Original Proposal:	18 September 2020	(Ref: PM20926_LRk)
Panel Approval:	23 October 2023	(Ref: PM20926IMz)
GPG Approval:	29 February 2024	(Ref: 20145_IGp)

• **Rev.1 (Nov 2006)**

No history file or TB document available.

• **New (1990)**

No history file or TB document available.

Part B. Technical Background

List of Technical Background (TB) documents for Recommendation No. 29:

Annex 1. **TB for Rev.2 (Feb 2024)**

See separate TB document in Annex 1.

Note: There are no separate Technical Background (TB) documents available for New (1990) and Rev.1 (June 2006).

Technical Background (TB) document for Rec.29 (Rev.2 Feb 2024)

1. Scope and objectives

IACS Recommendation No.29 provides a detailed list of recommended spare parts to be carried onboard for ships trading internationally. While the availability of spare parts onboard is considered by IACS members to be a matter for individual IACS members, who may or may not incorporate details within their Rules and Regulations, in response to industry feedback suggesting the IACS Recommendations for spare parts, in particular Rec.26, were out of date and no longer reflected the design of modern engines and other essential machinery and equipment, IACS members agreed revision was appropriate resulting in the publication of Rev.2 for each of the Recommendations.

2. Engineering background for technical basis and rationale

While the feedback from industry indicated a preference for IACS to publish a detailed, prescriptive list of spare parts to be carried onboard, in recognition of the increasing rate at which new, highly complex technologies were being developed and deployed onboard ships, Machinery Panel members agreed that a prescriptive approach was no longer tenable, and a risk-based approach, realised through the application of risk assessment techniques, was appropriate. It was agreed to retain the detailed prescriptive lists from Rev.1 of the Recommendations as examples only.

2a. Specification of the data utilised in the development/revision of the proposed IACS Recommendation, if any

None.

3. Source/derivation of the proposed IACS Recommendation

Derivation of the revised Recommendation is based on practical knowledge of IACS members in the application of risk assessment techniques informed by comments from MARTECMA and CIMAC.

4. Summary of Changes intended for the revised IACS Recommendation:

The list of spare parts recommended to be carried onboard in Rev.1 of Rec.29 is retained in Rev.2 but is changed to an example of spare parts recommended to be carried onboard. This example becomes Section 2. A new Section 1. is introduced into the Recommendation describing the need for a risk-based approach for the determination of spare parts to be carried onboard and makes cross-reference to Rec. 26. for the risk-based approach recommended to be followed, since it is the same for each of the recommendations, rather than repeating the text.

5. Points of discussions or possible discussions

Draft Rev.2 Recommendation was initiated by comments received from MARTECMA focused particularly on Rec.26. The comments were extensively discussed by Machinery Panel members and are detailed in the HF+TB for Rec.26.

The additional discussion in the Machinery Panel related specifically to Recommendations 27 to 30 was regarding the proposal to follow the same risk base approach as described in Rec.26 and if so, to make cross-reference to Rec.26 rather

than reproducing the same text in each of the Recommendations 27 to 30, both of which were agreed.

Further, the changes made to the detailed list in Rev.2 of Rec.26 were also agreed for incorporation into the detailed lists in Recommendations 27 to 30.

Draft of REC reviewed by **SuP** and **CIMAC** without comments.

6. Attachments if any

None

Recommendation No.30 “List of minimum recommended spare parts for essential auxiliary machinery of ships for unrestricted service”

Summary

Prior to this latest revision, Recommendation No.30 Rev.1 detailed the minimum spare parts to be carried onboard for certain essential auxiliary machinery of ships for unrestricted service. Following feedback from industry suggesting that the IACS Recommendations for spare parts are out of date, with particular mention of Rec.26 for main engine spares, all of the Recommendations related to spare parts have been revised in Rev.2 to recommend a risk-based approach to determination of the minimum spare parts to be carried onboard and the detailed lists of spare parts are retained as examples only.

Part A. Revision History

Version no.	Approval date	Implementation date when applicable
Rev.2 (Feb 2024)	29 February 2024	-
Rev.1	Nov 2006	-
New	1990	-

• Rev.2 (Feb 2024)

1 Origin of Change:

- Request by non-IACS entity (MARTECMA)

2 Main Reason for Change:

In a communication with IACS GPG concerning IACS Recommendation Nos. 26 to 30, according to MARTECMA “*The lists have been produced a long time ago under an obsolete technological environment*” i.e. they need updating to take account of current technology and the associated spares required.

3 List of non-IACS Member classification societies contributing or participating in IACS Working Group:

CIMAC – International Council on Combustion Engines

MARTECMA – Marine Technical Managers Association.

4 History of Decisions Made:

GPG requested that the Machinery Panel consider the communication received from MARTECMA suggesting that Recommendations 26 to 30 required updating. The majority of Machinery Panel members agreed on the need for a revision of the Recommendations. Four members preferred that the Recommendations be withdrawn.

Given the subject matter of the Recommendations, Machinery Panel members agreed to seek proposals for the revision from both CIMAC and MARTECMA. Form A was prepared which included cooperation with industry including CIMAC and MARTECMA. Information was received back from MAN ES via CIMAC and from MARTECMA as a consequence.

5 Other Resolutions Changes:

None.

6 Any hinderance to MASS, including any other new technologies:

None.

7 Dates:

Original Proposal:	18 September 2020	(Ref: PM20926_LRk)
Panel Approval:	23 October 2023	(Ref: PM20926IMz)
GPG Approval:	29 February 2024	(Ref: 20145_IGp)

• **Rev.1 (Nov 2006)**

No history file or TB document available.

• **New (1990)**

No history file or TB document available.

Part B. Technical Background

List of Technical Background (TB) documents for Recommendation No.30:

Annex 1. TB for Rev.2 (Feb 2024)

See separate TB document in Annex 1.

Note: There are no separate Technical Background (TB) documents available for New (1990) and Rev.1 (June 2006).

Technical Background (TB) document for Rec.30 (Rev.2 Feb 2024)

1. Scope and objectives

IACS Recommendation No.30 provides a detailed list of recommended spare parts to be carried onboard for ships trading internationally. While the availability of spare parts onboard is considered by IACS members to be a matter for individual IACS members, who may or may not incorporate details within their Rules and Regulations, in response to industry feedback suggesting the IACS Recommendations for spare parts, in particular Rec.26, were out of date and no longer reflected the design of modern engines and other essential machinery and equipment, IACS members agreed revision was appropriate resulting in the publication of Rev.2 for each of the Recommendations.

2. Engineering background for technical basis and rationale

While the feedback from industry indicated a preference for IACS to publish a detailed, prescriptive list of spare parts to be carried onboard, in recognition of the increasing rate at which new, highly complex technologies were being developed and deployed onboard ships, Machinery Panel members agreed that a prescriptive approach was no longer tenable, and a risk-based approach, realised through the application of risk assessment techniques, was appropriate. It was agreed to retain the detailed prescriptive lists from Rev.1 of the Recommendations as examples only.

2a. Specification of the data utilised in the development/revision of the proposed IACS Recommendation, if any

None.

3. Source/derivation of the proposed IACS Recommendation

Derivation of the revised Recommendation is based on practical knowledge of IACS members in the application of risk assessment techniques informed by comments from MARTECMA and CIMAC.

4. Summary of Changes intended for the revised IACS Recommendation:

The list of spare parts recommended to be carried onboard in Rev.1 of Rec.30 is retained in Rev.2 but is changed to an example of spare parts recommended to be carried onboard. This example becomes Section 2. A new Section 1. is introduced into the Recommendation describing the need for a risk-based approach for the determination of spare parts to be carried onboard and makes cross-reference to Rec. 26. for the risk-based approach recommended to be followed, since it is the same for each of the recommendations, rather than repeating the text.

5. Points of discussions or possible discussions

Draft Rev.2 Recommendation was initiated by comments received from MARTECMA focused particularly on Rec.26. The comments were extensively discussed by Machinery Panel members and are detailed in the HF+TB for Rec.26.

The additional discussion in the Machinery Panel related specifically to Recommendations 27 to 30 was regarding the proposal to follow the same risk base approach as described in Rec.26 and if so, to make cross-reference to Rec.26 rather

than reproducing the same text in each of the Recommendations 27 to 30, both of which were agreed.

Draft of REC reviewed by **SuP** and **CIMAC** without comments.

6. Attachments if any

None

Rec. No.31 "Recommended procedure for inclining test"

Summary

Recommendation No.31 is updated to refer to the 2008 IS Code.

Part A. Revision History

Version no.	Approval date	Implementation date when applicable
Rev.3 (Apr 2023)	4 April 2023	-
Corr.1 (Jan 2004)		
Rev.2 (June 2002)		
Rev.1 (June 2000)		
Corr (Aug.1998)		
Corr (1997)		
New (1990)		

- **Rev.3 (Apr 2023)**

1 Origin of Change:

- Other (10th anniversary review)

2 Main Reason for Change:

Rec. No.31 needed to be updated to ensure consistency with Annex 1 of the 2008 IS Code.

3 List of non-IACS Member classification societies contributing or participating in IACS Working Group:

None

4 History of Decisions Made:

An amendment to Rec.No.31 to include a reference to Annex 1 of the 2008 IS Code was discussed and agreed by correspondence in the Safety Panel.

5 Other Resolutions Changes:

None

6 Any hinderance to MASS, including any other new technologies:

None

7 Dates:

Original Proposal	:15 November 2022	(Ref: PS19002_PRg)
Panel Approval	:5 December 2022	(Ref: PS19002zbISb)
GPG Approval	:4 April 2023	(Ref: 22183_IGd)

- **Rev.2 Corr.1 (Jan 2004)**

No HF information available.

- **Rev.2 (June 2002)**

No HF information available.

- **Rev.1 (June 2000)**

No HF information available.

- **Corr (Aug. 1998)**

No HF information available.

- **Corr (1997)**

No HF information available.

- **New (May 1998)**

No HF information available.

Part B. Technical Background

List of Technical Background (TB) documents:

Note: No Technical Background documents are available for any versions of this recommendation.

Recommendation No.33 “Guidelines for the Construction of Pressure Vessel Type Tanks Intended for the Transportation of Anhydrous Ammonia at Ambient Temperatures”

Summary

Recommendation No.33 was deleted, taking into account the presence of a relative IMO instrument (the IGC Code).

Part A. Revision History

Version no.	Approval date	Implementation date when applicable
Del (Mar 2021)	18 March 2021	-
Corr.1 (1992)	1992	-
New (1992)	1992	-

- **Del (Mar 2021)**

1 Origin of Change:

- Other (Periodical review carried out by Machinery Panel)

2 Main Reason for Change:

Recommendation No.33 was deleted, taking into account the presence of a relative IMO instrument (the IGC Code).

3 List of non-IACS Member classification societies contributing or participating in IACS Working Group:

None

4 History of Decisions Made:

None

5 Other Resolutions Changes:

None

6 Any hinderance to MASS, including any other new technologies:

None

7 Dates:

Original Proposal: 28 October 2019 (Ref: PM18939_IMd)
Panel Approval: 9 November 2020 (Ref: PM20906_IMf)
GPG Approval: 18 March 2021 (Ref: 20206clGd)

- **Corr.1 (1992)**

No history files or TB document available.

- **New (1992)**

No history files or TB document available.

Part B. Technical Background

List of Technical Background (TB) documents for Recommendation No.33:



Note: *There are no Technical Background (TB) documents available for the New (1992), Corr.1(1992) and Del (Mar 2021).*

Recommendation No. 34 "Standard Wave Data"

Summary

Rec 34 is revised with validated wave data combined with ship traffic information including evaluations of bad weather avoidance. Recommendations of vessel speed in adverse seas and effect of heading distribution for direct analyses are included.

Part A. Revision History

Version no.	Approval date	Implementation date when applicable
Rev.2 (Dec 2022)	19 December 2022	-
Corr.1 (Nov 2001)	November 2001	-
Rev.1 (June 2000)	June 2000	-
New (1992)	1992	-

• Rev.2 (Dec 2022)

1 Origin of Change:

- Based on IMO Regulation (GBS - SOLAS II-1/3-10)

2 Main Reason for Change:

It has been observed during the GBS verification that "Modern data show both an increase in mean significant wave height for the North Atlantic and that more extreme weather is being experienced in recent years, including the existence of rogue waves and the possible effect of climate change."

IACS Recommendation No. 34 revision 1 is based on old wave statistics from visual eyeball observations. Revision 2 is updated with modern hindcast data originating from a model with documented good accuracy in the North Atlantic area.

3 List of non-IACS Member classification societies contributing or participating in IACS Working Group:

None

4 History of Decisions Made:

During Hull Panel workshop held in September 2016 in London on Longitudinal Strength Harmonization, it was stated that UR S11, S11A and CSR are intended to be harmonized and to avoid double work, PT PH40 was formed to set up a plan and budget for updating the recommendation No 34 before going forward in the strength harmonization (loads, etc.). In January 2018 the plan and budget was approved and PT PH40 started the work on updating Recommendation No 34.

5 Other Resolutions Changes:

The following rules and unified requirements relate to IACS Recommendation No. 34

- CSR rules
- UR-S11
- UR-S11a

6 Any hinderance to MASS, including any other new technologies:

The recommendation has been derived for manned ships; it may be suitable for Maritime Autonomous Surface Ships (MASS) if similar design criteria and operational limits are applied.

7 Dates:

Original Proposal	: 01 December 2017	(Made by Hull Panel Chair 17176_PHa)
Panel Approval	: 30 November 2022	(Ref: PH17013_IHba)
GPG Approval	: 19 December 2022	(Ref: 17176_IGh)

- **Corr.1 (Nov 2001)**

No records are available

- **Rev.1 (June 2000)**

No records are available

- **New (1992)**

No records are available

Part B. Technical Background

List of Technical Background (TB) documents for Rec 34:

Annex 1. **TB for Rev.2 (Dec 2022)**

See separate TB document in Annex 1.

Note: There are no separate Technical Background (TB) documents available for New (1992), Rev.1 (June 2000) and Corr.1 (Nov 2001).

Technical Background (TB) document for Rec 34 (Rev.2 Dec 2022)

1 Scope and objectives

IACS Recommendation No. 34, hereafter Rec.34, describes wave statistics intended for design of sea-going ships above 90 meters including the effect of bad weather avoidance. It is based on North Atlantic trade, which represents the most severe conditions ships tend to operate in. The recommendation includes advice on sea states as well as wave spectrum, spreading, heading distribution and vessel speed. The update from revision 1 to revision 2 is expected to lead to consequent changes in design loads such as pressures, motions, accelerations and hull girder loads.

2 Engineering background for technical basis and rationale

Rec.34 revision 1, hereafter Rec.34 v1, was based on human eyeball observations of significant wave heights and periods from sea-going ships. For a long time, these were considered the best data available for the purpose. An evaluation of available hindcast wave data bases was performed by IACS in 2020 [1] showing that modern wave models have sufficient quality to act as basis for a revision 2 of Rec.34. Detailed information of the work is given in section 5.

3 Source/derivation of the proposed IACS Resolution

None; work has been conducted entirely within IACS.

4 Summary of Changes intended for the revised Resolution:

No side-by-side comparison of text is included here as revision 2 represents a major change of Rec34; but Table 4-1 summarises the main changes.

Table 4-1 Changes between revision 1 and 2

	Revision 1	Revision 2
Source of wave data	Eyeball	Hindcast
Wave spectrum	Pierson Moskowitz	JONSWAP, gamma=1.5
Cosine wave spreading power	2	3
Design lifetime	Not defined	25 years
Return period for extreme loads	At least 20 years	25 years
Reference probability level for fatigue	Not defined	10 ⁻²
Vessel speed for strength assessments	0 knots	5 knots
Vessel speed for fatigue assessments	Not defined	¾ design speed

Item 4, 5, 9, 10 and 11 from IACS Rec. No. 34 revision 1 are removed in IACS Rec. No. 34 revision 2.

5 Main technical discussion points

5.1 Data sources and geographical area

The update is based on a combination of data from two sources, (i) simulated historic wave data (ii) records of the time and location of relevant ships operating in the area under question. Furthermore, the geographical area representing the North Atlantic is redefined.

Particular points of discussion in the IACS working group with respect to and arising from the source data were:

Issue	Resolution
Which ships should be included?	The group decided to effectively restrict the work to the fleet of IACS members by means of a 90m length criterion – this means most commercial seagoing ships are included, such as merchant ships and passenger ships. Excluded are many fishing vessels, offshore vessels, naval ships and ships operating at fixed location e.g. FPSOs.
Choosing type of source for wave data	The group considered different sources such as eyeball derived atlases, buoy networks and satellite altimeters, but only global wave models (numerical hindcast) offered the spatial and temporal resolution required.
Choosing global wave model from several options	Several freely available public sources from major institutions were compared and found to be adequate; Commercially available weather services were also an option, but paid solution was not found necessary.
Accuracy of synthetic wave data	The group compared four different models against benchmark data from moored buoys and altimeters. Most were quite accurate at low to mid wave heights, the model IOWAGA was selected as it also performed very well at high wave heights.
Extent of historic synthetic wave data	Only 7 years was available to match the available AIS ship track data. It is argued that the huge volume of AIS data compensates a great deal for that limitation. Additionally, it was observed several of these 7 years were amongst the roughest ever recorded, meaning that possible bias due to the limited duration should at least lead to conservative design.
Procedure for fitting of idealised spectral models to the wave data	The group fitted idealised spectral shapes to non-dimensionalised spectra to find the best fitting spectral type and shape controlling parameters. The JONSWAP spectrum (developed for restricted North Sea waters) performed better than traditional open water spectra.
Choosing T0m1 as principal period	The group considered more common wave period measures such as Tz and Tp but found that T0m1 fitted best to the data. The group recognised that T0m1 is not so well known and provided conversion methods so users can work from the common period measures if necessary.
Accuracy of the AIS location records	The ship AIS records represent discrete lat/long positions. It was necessary to collate these into meaningful continuous voyages in the North Atlantic. Further it is necessary to 'clean' the records of occasional rogue and inconsistent data to ensure the reliability of those voyage records.
Is North Atlantic the most severe sea area?	The group reviewed global sea areas for their roughness using the modern wave model data. It was confirmed that, from a combined traffic and wave data set, both for extreme wave heights and for intermediate wave heights (relevant for fatigue design), the North Atlantic was most severe. The group confirmed that as well as for pure wave properties,

	similar conclusions would be reached considering ship responses.
Definition of the North Atlantic Ocean area	The working group chose to define the bounds for the North Atlantic for itself based on the geography, wave climate maps and shipping density maps. The historic definitions did not fit these criteria well. A point of discussion was how far south the area should extend, into areas with slightly less severe wave climate. The group eventually adopted the slightly larger of two candidates; this showed acceptable absolute values of safety level across all ship types, and also showed consistency of the safety level for both fatigue and strength design. A further point of discussion was whether the area should extend to the coasts of North America and Europe; a band was excluded so that purely coastal ship traffic was rejected from the analysis, also hindcast models are known to reduce in quality near to the shore.
How to include routing effect	The group could have defined a small number of fixed routes, or used long term mean traffic density data to produce a scatter diagram with some routing effect built in. But it was found technically possible to perform the best possible analysis by accumulating the scatter diagram data from thousands of individual in-voyage locations with individually co-located wave data. This naturally gives a full representation of the routing effect in a 'routed' scatter diagram. The group also found it useful to include 'unrouted' calculations for benchmarking purposes; for this analysis 30 years of hindcast data from the entire North Atlantic area was included so that weather avoidance effect was eliminated.
How to construct the scatter diagram	The cleaned AIS track records were interpolated every 3 hours to exactly match the time of the wave model hindcast. This lead directly to an empirical scatter diagram. An improvement on resolution (number of digits) was possible compared with Rec.34 v1. It was necessary to 'smooth' the empirical diagram so that the variation in sparsely sampled bins towards the edges do not create bias problems when extrapolating toward even lower probabilities.

The geographical area adopted in Rec.34 v2, shown in Figure 5-1, is defined as the polygon limited by the following latitude, longitude coordinates:

Start Point (Clockwise)

(60, -60), (60, -8), (56, -8), (56, -11), (50, -11), (50, -8), (44, -8), (44, -10), (32, -10), (32, -11), (30, -11), (30, -70), (40, -70), (40, -69), (43, -69), (43, -59), (46, -59), (46, -52), (50, -52), (50, -54), (54, -54), (55, -54), (55, -57), (56, -57), (56, -60) and (60, -60) **End Point.**

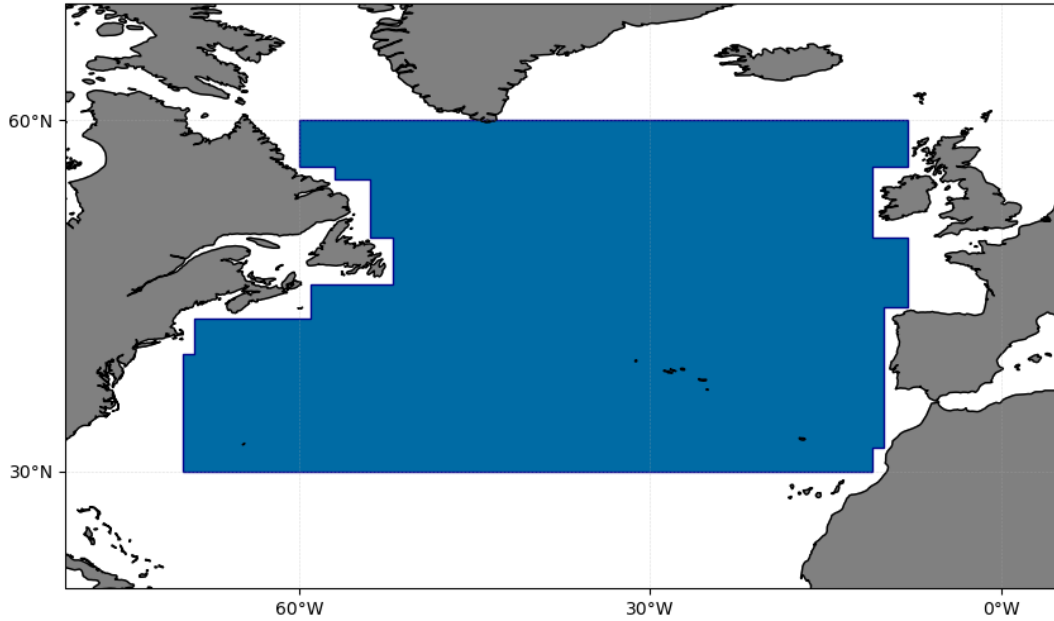

Figure 5-1 Definition of North Atlantic area

The evaluated data is made from a combined AIS-hindcast data set resampled at 3-hour interval for the period June 1st 2013 – May 31st 2020 covering the polygon defined in Figure 5-1. A total of 13.3 million observations are recorded from more than 23000 different vessels.

5.2 Scatter diagram including smooth fitting process

The previous section introduced the process followed by the IACS working group to derive Rec.34 v2 scatter diagram from a combination of vessel tracks and hindcast wave data.

Once the empirical scatter diagram was obtained from AIS and hindcast wave data, a statistical model was fitted. The statistical model smooths out some of the sampling uncertainties, allows extrapolation to unobserved wave periods and provides the scatter diagram in a compact form (the scatter diagram can be reconstructed at any desired resolution from a few coefficients).

The statistical model underlying Table 1 of Rec.34 v2 is written as:

$$p(H_s, T_{0m1}) = p_H(H_s) * p_{T_{0m1}}(T_{0m1}|H_s)$$

Where $p_H(H_s)$ is the marginal distribution of wave height, and $p_{T_{0m1}}$ is the conditional distribution of wave period.

A mixture of Weibull distributions with coefficients from Table 5-1 is used to model the marginal distribution:

$$P_H(H_s) = \chi F_{H,1}(H_s) - (1 - \chi)F_{H,2}(H_s) \\ = 1 - \chi \exp\left[-\left(\frac{H_s - \varepsilon}{\lambda_1}\right)^{\alpha_1}\right] - (1 - \chi) \exp\left[-\left(\frac{H_s - \varepsilon}{\lambda_2}\right)^{\alpha_2}\right]$$

Table 5-1 : Hs distribution coefficients.

	Unrouted	Routed
α_1	1.3460	1.4230
ε	0.9180	0.9360
λ_1	2.0610	1.8150

α_2	1.9130	1.3940
λ_2	5.0960	2.8050
χ	0.9507	0.9499

The conditional period distribution is a split generalised normal distribution:

$$p_{T_{0m1}}(t|H_s) = \begin{cases} c \cdot e^{-\left[\frac{x_0-t}{\sigma_l}\right]^{d_l}} & \text{for } t < x_0 \\ c \cdot e^{-\left[\frac{t-x_0}{\sigma_u}\right]^{d_u}} & \text{for } t \geq x_0 \end{cases}$$

With $c = \frac{1}{\sigma_l \Gamma\left(1+\frac{1}{d_l}\right) + \sigma_u \Gamma\left(1+\frac{1}{d_u}\right)}$

Parameters are then functions of H_s , with the following shapes and coefficients given in Table 5-2:

$$x_0(h_s) = l_0 + 1.0 * h_s + l_1 * h_s * \sqrt{h_s}$$

$$\sigma_u(h_s) = \begin{cases} su_2 + su_1 * (1 - \cos\left(\frac{\pi * h_s}{su_0}\right)) * 0.5 & \text{for } h_s < su_0 \\ (su_2 + su_1) * \cos(\sigma_d * \pi) & \text{for } h_s \geq su_0 \text{ with } \sigma_d = \frac{1}{1 + e^{-su_3 * (h_s - su_0)}} - 0.5 \end{cases}$$

$$\sigma_l(h_s) = sl_0 * h_s + sl_1$$

$$d_u = 2$$

$$d_l = 3$$

Table 5-2 : Conditional model coefficients.

	Unrouted	Routed
l_0	5.261561	5.427251
l_1	-0.086510	-0.085340
su_0	1.986849	2.549443
su_1	2.480241	2.435955
su_2	1.080E-06	0.705177
su_3	-0.162740	0.133225
sl_0	0.007157	0.018557
sl_1	0.969472	1.005918

Thus the final scatter diagram can be defined, with discretisation performed within 1m and 1s bins. Values in each bin are calculated using midpoints, except for the $H_s = [0.0m, 1.0m]$ where exact integration is used.

Table 5-3 : Routed

		Mean wave period, T_{0m1} (s)																
		4.5	5.5	6.5	7.5	8.5	9.5	10.5	11.5	12.5	13.5	14.5	15.5	16.5	17.5	18.5	19.5	Sum
Significant wave height, H_s (m)	0.5	6.82	202.00	333.61	187.76	45.59	4.74	0.21	0.00	0.00	0.00	0.00	0.00	0.00	0.00	0.00	0.00	780.73
	1.5	0.33	2028.35	12750.82	11693.39	7215.76	3006.80	846.07	160.77	20.63	1.79	0.10	0.00	0.00	0.00	0.00	0.00	37724.81
	2.5	0.00	3.38	2805.81	8517.74	7835.85	5885.37	3608.30	1805.81	737.71	246.00	66.96	14.88	2.70	0.40	0.05	0.00	31530.96
	3.5	0.00	0.00	23.06	2742.51	4666.81	4100.83	2936.41	1713.38	814.68	315.65	99.66	25.64	5.38	0.92	0.13	0.01	17445.07
	4.5	0.00	0.00	0.00	82.06	1759.81	2069.19	1715.42	1151.29	625.51	275.12	97.96	28.24	6.59	1.24	0.19	0.02	7812.64
	5.5	0.00	0.00	0.00	0.08	149.74	811.81	791.81	609.66	375.67	185.26	73.12	23.09	5.84	1.18	0.19	0.02	3027.47
	6.5	0.00	0.00	0.00	0.00	1.02	147.59	305.37	271.71	190.23	104.79	45.42	15.49	4.16	0.88	0.15	0.02	1086.83
	7.5	0.00	0.00	0.00	0.00	0.00	4.77	88.62	107.20	86.26	53.35	25.36	9.27	2.60	0.56	0.09	0.01	378.09
	8.5	0.00	0.00	0.00	0.00	0.00	0.02	9.40	38.70	36.80	25.95	13.63	5.33	1.55	0.34	0.05	0.01	131.78
	9.5	0.00	0.00	0.00	0.00	0.00	0.00	0.20	9.34	15.15	12.51	7.39	3.12	0.94	0.20	0.03	0.00	48.88
	10.5	0.00	0.00	0.00	0.00	0.00	0.00	0.00	0.81	5.73	5.96	4.08	1.90	0.60	0.13	0.02	0.00	19.23
	11.5	0.00	0.00	0.00	0.00	0.00	0.00	0.00	0.02	1.29	2.68	2.23	1.18	0.40	0.08	0.01	0.00	7.89
	12.5	0.00	0.00	0.00	0.00	0.00	0.00	0.00	0.00	0.11	1.01	1.14	0.72	0.27	0.06	0.01	0.00	3.32
	13.5	0.00	0.00	0.00	0.00	0.00	0.00	0.00	0.00	0.00	0.22	0.51	0.42	0.18	0.04	0.00	0.00	1.37
	14.5	0.00	0.00	0.00	0.00	0.00	0.00	0.00	0.00	0.00	0.02	0.19	0.21	0.12	0.03	0.00	0.00	0.57
	15.5	0.00	0.00	0.00	0.00	0.00	0.00	0.00	0.00	0.00	0.00	0.04	0.09	0.07	0.02	0.00	0.00	0.22
	16.5	0.00	0.00	0.00	0.00	0.00	0.00	0.00	0.00	0.00	0.00	0.00	0.03	0.04	0.01	0.00	0.00	0.08
	17.5	0.00	0.00	0.00	0.00	0.00	0.00	0.00	0.00	0.00	0.00	0.00	0.01	0.02	0.01	0.00	0.00	0.04
	18.5	0.00	0.00	0.00	0.00	0.00	0.00	0.00	0.00	0.00	0.00	0.00	0.00	0.00	0.01	0.01	0.00	0.00
Sum	7.15	2233.73	15913.30	23223.54	21674.58	16031.12	10301.81	5868.69	2909.77	1230.31	437.79	129.62	31.47	6.11	0.92	0.09	100000.00	

Table 5-4 : Unrouted

		Mean wave period, T_{0m1} (s)																
		4.5	5.5	6.5	7.5	8.5	9.5	10.5	11.5	12.5	13.5	14.5	15.5	16.5	17.5	18.5	19.5	Sum
Significant wave height, H_s (m)	0.5	20.86	400.31	508.13	174.39	17.04	0.47	0.00	0.00	0.00	0.00	0.00	0.00	0.00	0.00	0.00	0.00	1121.20
	1.5	0.62	2897.82	12015.92	10074.26	5442.95	1892.83	423.69	61.04	5.66	0.34	0.01	0.00	0.00	0.00	0.00	0.00	32815.14
	2.5	0.00	5.93	4108.88	9207.22	7617.69	4546.87	1957.92	608.24	136.32	22.04	2.57	0.22	0.01	0.00	0.00	0.00	28213.91
	3.5	0.00	0.00	41.48	4168.26	5773.19	4399.97	2392.91	928.64	257.16	50.82	7.17	0.72	0.05	0.00	0.00	0.00	18020.37
	4.5	0.00	0.00	0.00	173.75	3040.91	3117.84	2125.34	1010.71	335.31	77.61	12.53	1.41	0.11	0.01	0.00	0.00	9895.53
	5.5	0.00	0.00	0.00	0.12	403.33	1739.52	1509.92	883.00	347.48	92.01	16.40	1.97	0.16	0.01	0.00	0.00	4993.92
	6.5	0.00	0.00	0.00	0.00	2.66	522.98	892.46	660.17	311.83	94.05	18.11	2.23	0.17	0.01	0.00	0.00	2504.67
	7.5	0.00	0.00	0.00	0.00	0.00	21.82	416.47	432.17	254.45	88.92	18.44	2.27	0.17	0.01	0.00	0.00	1234.72
	8.5	0.00	0.00	0.00	0.00	0.00	0.04	67.68	242.23	190.45	80.64	18.34	2.24	0.15	0.01	0.00	0.00	601.78
	9.5	0.00	0.00	0.00	0.00	0.00	0.00	1.27	91.23	125.41	69.92	18.29	2.24	0.13	0.00	0.00	0.00	308.49
	10.5	0.00	0.00	0.00	0.00	0.00	0.00	0.00	9.21	66.73	55.17	18.16	2.34	0.12	0.00	0.00	0.00	151.73
	11.5	0.00	0.00	0.00	0.00	0.00	0.00	0.00	0.11	19.68	35.65	17.24	2.54	0.11	0.00	0.00	0.00	75.33
	12.5	0.00	0.00	0.00	0.00	0.00	0.00	0.00	0.00	1.48	16.92	14.29	2.84	0.12	0.00	0.00	0.00	35.65
	13.5	0.00	0.00	0.00	0.00	0.00	0.00	0.00	0.00	0.02	4.12	8.75	3.08	0.15	0.00	0.00	0.00	16.12
	14.5	0.00	0.00	0.00	0.00	0.00	0.00	0.00	0.00	0.00	0.28	3.65	2.84	0.21	0.00	0.00	0.00	6.98
	15.5	0.00	0.00	0.00	0.00	0.00	0.00	0.00	0.00	0.00	0.00	0.81	1.72	0.29	0.00	0.00	0.00	2.82
	16.5	0.00	0.00	0.00	0.00	0.00	0.00	0.00	0.00	0.00	0.00	0.06	0.64	0.36	0.00	0.00	0.00	1.06
	17.5	0.00	0.00	0.00	0.00	0.00	0.00	0.00	0.00	0.00	0.00	0.00	0.14	0.26	0.01	0.00	0.00	0.41
	18.5	0.00	0.00	0.00	0.00	0.00	0.00	0.00	0.00	0.00	0.00	0.00	0.01	0.09	0.02	0.00	0.00	0.12
19.5	0.00	0.00	0.00	0.00	0.00	0.00	0.00	0.00	0.00	0.00	0.00	0.00	0.02	0.03	0.00	0.00	0.05	
Sum	21.48	3304.06	16674.41	23798.00	22297.77	16242.34	9787.66	4926.75	2051.98	688.49	174.82	29.45	2.68	0.11	0.00	0.00	100000.00	

5.3 Spectrum shape

Rec.34 v1 requires a two parameter Pierson-Moskowitz spectrum (equivalent to JONSWAP with gamma = 1.0), with associated cos² spreading. Analysis of full spectra from hindcast wave data has shown that a JONSWAP spectrum with peakedness parameter gamma = 1.5 and cos³ spreading was more appropriate to represent extreme sea states for Rec.34 v2. Furthermore, this spectral shape also provides accurate results for fatigue loads. This section provides some background justification.

The full spectra data here analysed are from the model ERA5 [5], at a single point located in the North Atlantic, over the period 1990-2014.

Figure 5-2 shows the shape of 306 sea-state spectra contributing the most to the 25-years extreme ($\sim H_s > 10\text{m}$), normalised according to alternative wave period measures T_{0m1} , T_p or T_z . The extreme sea states have remarkably constant shape and seem to be well represented by a JONSWAP spectrum with $\gamma = 1.5$ (rounding from the raw least-square minimisation value 1.43). It was also observed that matching T_{0m1} or T_p provides much better results than T_z .

A slight trend of γ increasing with H_s was observed; however, it was found that with other parameters fixed, varying γ did not significantly change the overall accuracy of ship responses. For simplicity and practicality, a γ varying as a function of H_s was therefore not adopted and γ fixed at 1.5 was recommended.

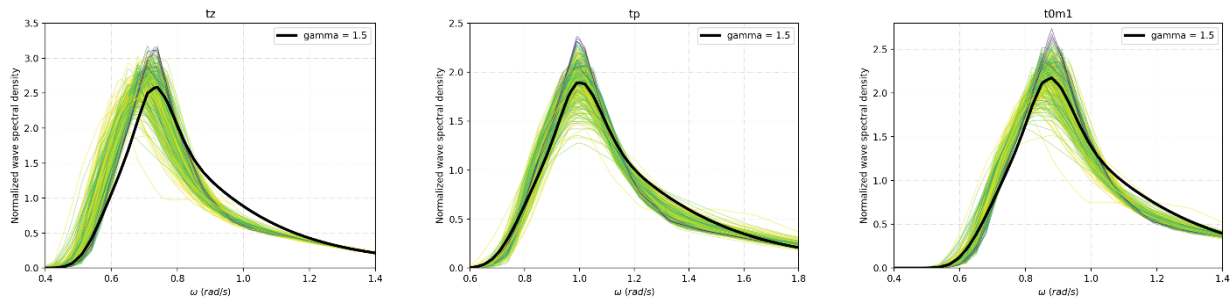

Figure 5-2 Shape of contributing spectrum ($H_s > 10\text{m}$) and parameterised spectra (JONSWAP, $\gamma = 1.5$), based on 25 years of data

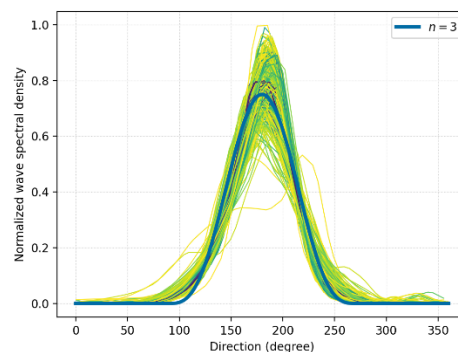

Figure 5-3 : Shape of contributing spectrum ($H_s > 10\text{m}$) - directionality

Similarly, Figure 5-3 shows the directional shape of sea states contributing to the extreme. As with the frequency shape, the directional spreading is very similar among the different sea-states and well approximated by a \cos^n formulation with $n=3$.

Finally, to evaluate the accuracy loss induced by this simple parametrisation, a validation was performed in on a database of 50 bulk carrier, tanker and container vessels. The following responses were analysed:

- Vertical wave bending moment
- Horizontal bending moment
- Pitch
- Roll

Those four RAOs (multiplied by 50 ships) are believed to represent a sufficiently broad and representative variety of possible response characteristic shapes.

The 25 years extreme value were calculated for all ship responses:

- using full spectra (reference)
- using $\gamma = 1.0$ and $n = 2$ (Rec.34 v1)
- using $\gamma = 1.5$ and $n = 3$ (Rec.34 v2)

The Rec.34 v1 shape resulted in a 7% quadratic error compared with the reference, which reduced to 5% using Rec.34 v2 parameter.

Fatigue loads (at 10^{-2} probability) are less sensitive to spectrum shape. With the same test cases, Rec.34 v1 and Rec.34 v2 results had quadratic error of 2.7% and 3.2% respectively compared with the reference. Those errors are considered comparable and acceptable.

Those findings are confirmed by a similar analysis conducted at several global locations [2].

5.4 Vessel speed and relative wave heading

5.4.1 Introduction

Rec.34 v1 included recommendations for how ships are assumed to operate in different sea conditions. Equal probability for all ship headings was applied in long-term prediction of various wave-induced responses. Zero speed was assumed when evaluating extreme wave loads in extreme sea conditions for strength assessment.

In this section, summarising results from the combined AIS-hindcast dataset specified in 5.1, basic estimates are made of the probability distributions of ship speeds and relative wave headings in sea states actually encountered according to the wave model.

5.4.2 Results and discussions on ship speeds and relative wave heading

5.4.2.1 Sensitivity of responses to relative wave heading

The probability distributions of the relative wave headings in different ranges of the hindcast encountered significant wave heights (hereafter, H_s) are investigated. It is noted:

- There is no significant difference for all relative wave headings when H_s is less than 6m.
- The probability of the relative wave headings in bow seas from starboard (120 deg. and 150 deg.) and quartering sea from portside (330 deg.) increases when H_s becomes higher than 6m.
- The probability of the relative wave heading in bow sea from starboard (150 deg.) increases a little bit more (several percentages) when H_s is larger than 10m.

Figure 5-4 shows the probability distribution of the relative wave headings when H_s is larger than 10m. It is observed that the bow sea from starboard (150 deg.) is the most probable. This is also consistent with the distribution from worldwide trade.

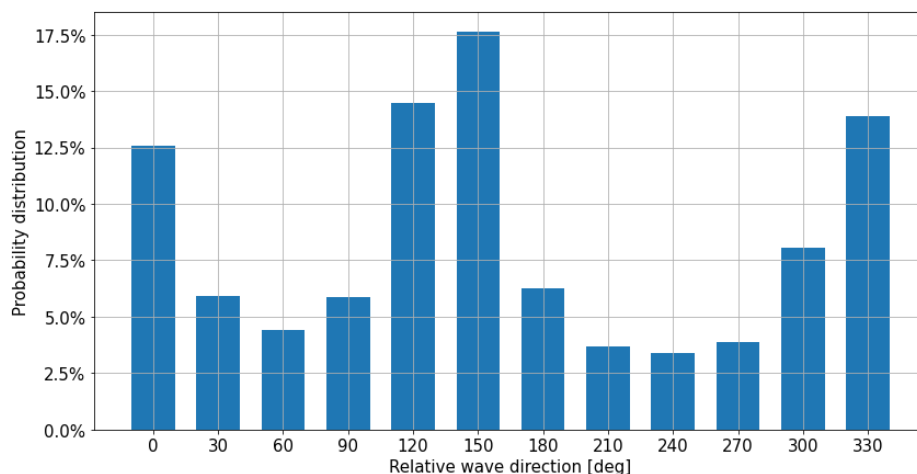

Figure 5-4 Probability distribution of relative wave headings when $H_s \geq 10.0m$

Rec.34 v1 recommends a uniform distribution of ship headings relative to the waves for long term predictions of wave-induced responses. In this sub-section, results using this uniform probability

distribution shall be called "Upd". In reality, the probability distribution of the relative wave headings is not uniform in rough seas, as shown in Figure 5-4. Results are also calculated by this non uniform distribution shall be called "N-Upd".

In order to investigate the sensitivity to relative wave headings with regard to Hs, the long-term prediction values of eight wave-induced responses listed below are calculated for both "Upd" and "N-Upd".

- Vertical as well as horizontal wave bending moment amidships (Mwv, Mwh);
- Heave, Roll and Pitch motions (Heave, Roll, Pitch);
- Vertical acceleration at the centreline of FP (Azclfp);
- External pressure at the waterline and bottom centreline amidships (Pwlmi, Pclmi).

Table 5-5 shows the overview of ships used for this work. The sensitivity is investigated based on a series of direct analyses by a linear strip method program. For each ship, full loading condition is chosen. Similar to Rec.34 v1, the Pierson-Moskowitz wave spectrum, spreading function of \cos^2 and the Rec. 34 v1 wave scatter diagram are used. The ratios (N-Upd results / Upd results) of the eight wave-induced responses were checked to quantify the sensitivity to heading distribution, for long-term prediction values at probability level 10^{-8} ; these are shown in Figure 5-5. Moreover, the ratio statistics (mean values, maximum and minimum values, standard deviation and coefficient of variation) are summarised in Table 5-6.

Table 5-5 Overview of the bulk carriers, oil tankers and container ships used in the investigation

Type	Numbers	Lpp (m)	B (m)
Bulk Carrier	22	107 - 285	20 - 50
Oil Tanker	27	110 - 322	20 - 60
Container ship	26	110 - 350	18 - 59

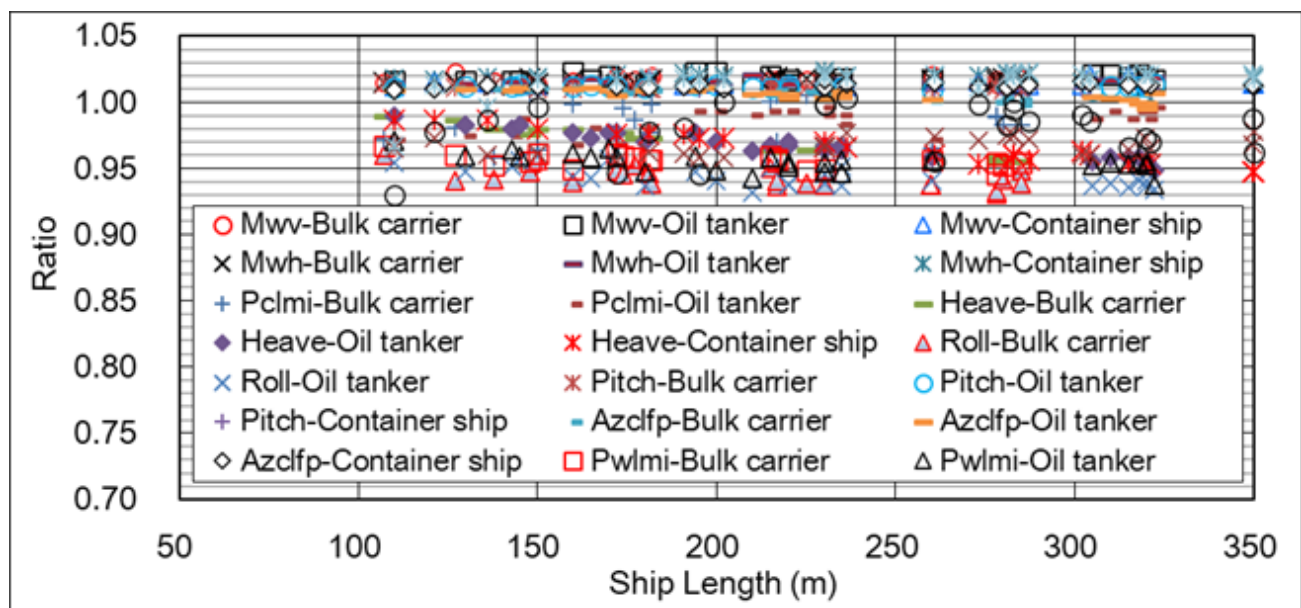

Figure 5-5 Sensitivity to heading distribution: Ratios (non-uniform / uniform) of the eight wave-induced responses at the 10^{-8} probability level for sample of 75 ships

Table 5-6 Ratio (non-uniform / uniform) statistics of the eight wave-induced responses at 10^{-8} for 75 ships

Response Items	Bulk Carrier					Oil Tanker					Container Ship				
	Ratio					Ratio					Ratio				
	Mean	Sdv	CV	Max.	Min.	Mean	Sdv	CV	Max.	Min.	Mean	Sdv	CV	Max.	Min.
Mwv	1.017	0.002	0.002	1.023	1.013	1.017	0.003	0.003	1.023	1.013	1.015	0.002	0.002	1.021	1.011
Mwh	1.016	0.002	0.002	1.019	1.013	1.016	0.002	0.002	1.021	1.013	1.019	0.004	0.004	1.024	1.003
Heave	0.969	0.011	0.011	0.990	0.955	0.968	0.010	0.011	0.990	0.949	0.965	0.012	0.013	0.986	0.948
Roll	0.943	0.008	0.008	0.961	0.931	0.943	0.008	0.009	0.963	0.931	0.980	0.019	0.020	1.004	0.930
Pitch	1.011	0.001	0.001	1.014	1.009	1.012	0.001	0.001	1.014	1.009	1.012	0.001	0.001	1.014	1.010
Azclfp	1.007	0.004	0.004	1.012	0.999	1.006	0.004	0.004	1.011	0.995	1.013	0.002	0.002	1.017	1.010
Pwlmi	0.956	0.005	0.005	0.967	0.946	0.955	0.007	0.007	0.971	0.938	0.967	0.007	0.007	0.978	0.955
Pclmi	0.986	0.016	0.016	1.018	0.959	0.986	0.009	0.009	0.997	0.969	1.016	0.011	0.011	1.023	0.968

From the obtained results, the sensitivity (ratio) to relative wave headings regarding the various wave-induced responses at the probability level 10^{-8} could be summarised as follows:

- There is some variation in the sensitivity (ratio) across the various wave-induced responses, but the variation is relatively limited and small.
- The mean values of the ratios of various wave-induced responses are around 0.956 to 1.017.
- The mean value of the ratios of eight wave-induced responses for all 75 ships is almost 1.000.
- The mean values of the ratios increase 1% to less 2% for Mwv, Pitch and Azclfp which are known to be dominated by head sea (180 deg.), bow sea (150 deg.) or following sea (0 deg.).
- The mean values of the ratios decrease 3% to 5% for Heave, Roll, Pwlmi which are known to be dominated by beam sea (90 deg.).
- The mean value of the ratio increases about 1.7% for Mwh which is known to be dominated by bow sea (120 deg.).
- The standard deviations of the ratios regarding various wave-induced responses are about 0.001 to 0.019.

Based on the results and discussions mentioned above, it could be concluded that equal probability of occurrence as indicated in Rec.34 v1 for the extreme wave loads for strength assessment remains practical and reasonable to be continued in Rec.34 v2.

5.4.2.2 Sensitivity of responses to ship speeds

This sub-section investigates the relationship when H_s , ship speed, and relative wave heading are considered simultaneously. The response sensitivity to ship speeds alone is also studied.

Generally, ships tend to reduce their speed in rough seas, to ensure the safety and integrity of hull structure, fittings and loaded cargoes. The technical background of IACS Common Structural Rule for Bulk Carriers and Oil Tankers [3] (hereafter, the TB-CSR) indicates 5 knots as the ship speed corresponding to the extreme wave loads for strength assessment and 3/4 of the design speed corresponding to the wave loads for fatigue assessment. In order to evaluate ship speed reduction, the relationships between ship speed, H_s and relative wave heading are investigated.

Figure 5-6 shows the relationships between the average relative ship speed (Average speed/Design speed) with H_s and relative wave headings. The relative speed in head sea (180 deg.), bow seas (120 deg. to 240 deg.), beam seas (90 deg. and 270 deg.) and quartering seas (60 deg. and 300 deg.) decrease inversely with H_s , but the degree of ship speed reduction is a bit different for different relative wave headings. On the other hand, the relative speed in following sea (0 deg.) and quartering seas (30 deg. and 330 deg.) show almost no decrease when H_s become higher. This tendency seems appropriate since the ships generally reduce speed when encountering rough waves, especially in head, bow and beam seas. The possible reasons causing ship speed reduction are considered to be voluntary in ship operation or involuntary natural speed loss due to wave resistance increased by high waves.

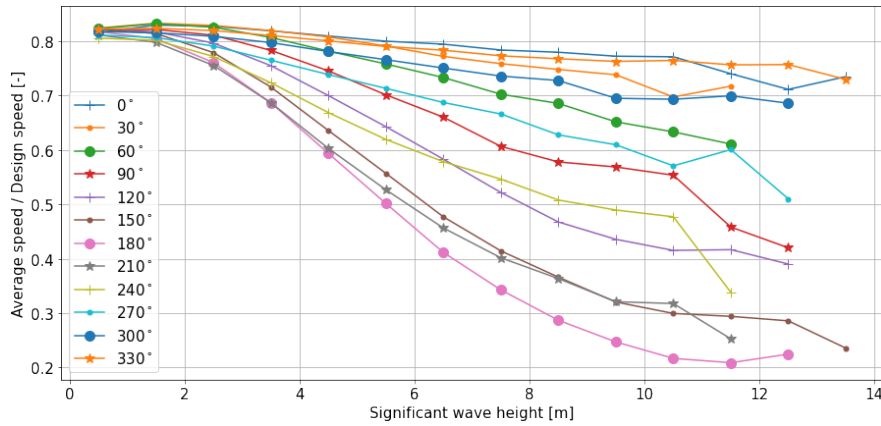

Figure 5-6 Average ship speed as function of Hs and relative wave heading

Figure 5-7 shows the head sea behaviour in more detail. The red line indicates median value, the box covers the 25th to 75th percentile range and the whiskers represent the 1st to 99th percentile range. It is observed that the ships reduce speed below 5 knots in extreme sea states.

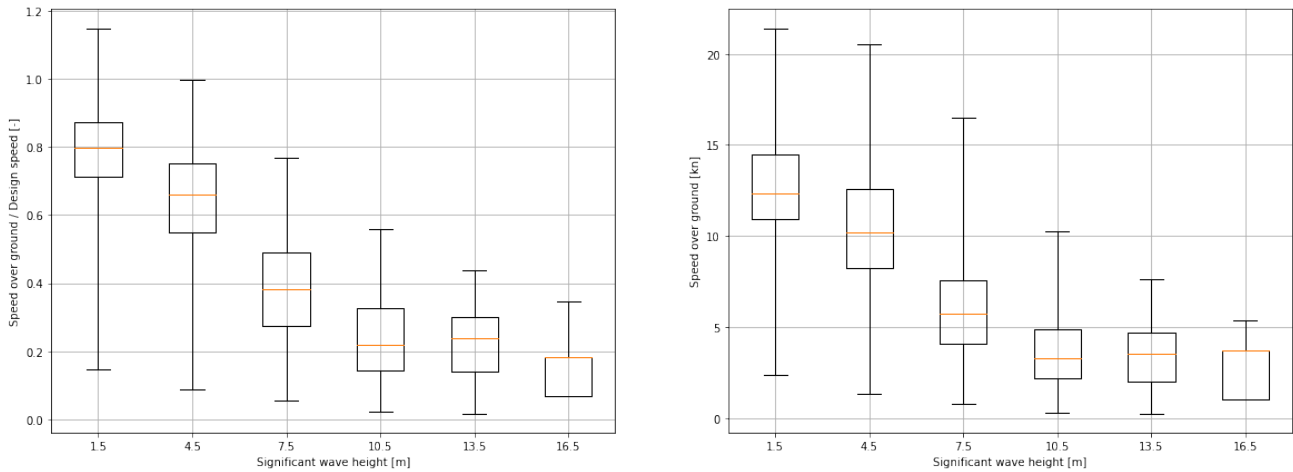

Figure 5-7 Relative and absolute ship speed in head sea as function of Hs. Box: 25th-75th percentiles, Whiskers:1st-99th percentiles

As mentioned above, 5 knots speed is the standard ship speed used for the extreme wave loads for strength assessment in the TB-CSR. The RAOs of various wave-induced responses (hull girder forces/bending moments, ship motions, acceleration and hydrodynamic pressures) in 5 knots for all relative wave headings are used when predicting extreme wave loads. However, in reality the ship speed varies at different relative wave headings in different extreme wave heights, as shown in Figure 5-6. In this sub-section, the possible consequences of allowing varying speed instead of the fixed 5 knots on the wave-induced responses in extreme waves are checked. The extreme waves are used as it is expected that the extreme wave loads arise from the extreme wave conditions. The results shown in Figure 5-6 have been simplified in the following way to select RAOs at appropriate speeds for this study:

- 0.75Vs: for following sea (0 deg.), quartering seas (30 deg. and 330 deg.)
- 0.50Vs: for quartering seas (60 deg. and 300 deg.) and beam seas (90 deg. and 270 deg.)
- 5 knots: for head sea (180 deg.) and bow seas (120 deg., 150 deg., 210 deg. and 240 deg.).

Hereafter, the RAOs varied with the ship speed for different relative wave headings mentioned above are called "RAOs (SP)", while the RAOs at the 5 knots fixed speed for different relative wave headings are called "RAOs (5)" in the following long-term predictions. To investigate the sensitivity to ship speed regarding Hs and relative wave headings, the long-term prediction values of eight responses specified in 5.4.2.1 are calculated for both "RAOs (SP)" and "RAOs (5)" at the probability level 10^{-8} based on the scatter diagram in Rec.34 v1. Other items (loading condition,

wave spectrum, spreading function) in the calculation are all same as those used in 5.4.2.1. Furthermore, uniform ship heading probability distribution is applied in the all wave headings long-term prediction. The long term prediction results are presented in the form of the ratio Load [RAOs(SP)] / Load [RAOs(5)].

The ratios obtained for the eight wave-induced responses are shown in Figure 5-8. Moreover, the statistics of the ratios (mean, maximum and minimum values, standard deviation and coefficient of variation) are summarised in Table 5-7.

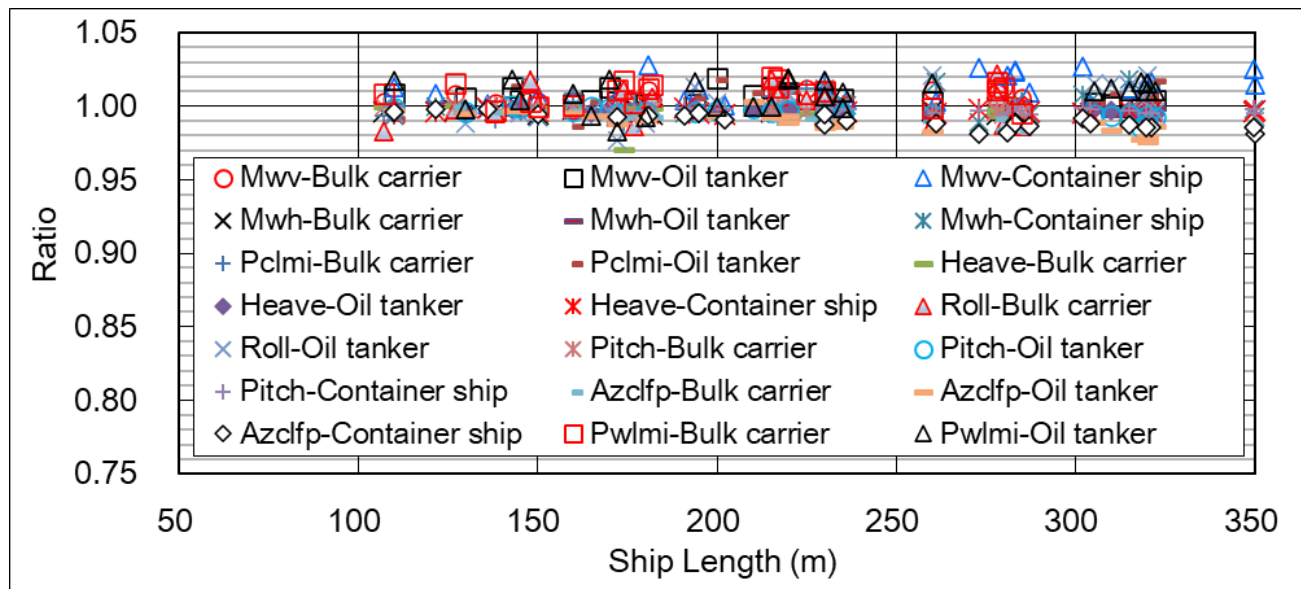

Figure 5-8 Ratio of loads (varying speed / 5 knots fixed speed) of the eight wave-induced responses at 10^{-8} probability level for sample of 75 ships

Table 5-7 Ratio statistics of the eight wave-induced responses at 10^{-8} for 75 ships

Bulk Carrier					Oil Tanker					Container Ship				
Ratio					Ratio					Ratio				
Mean	Sdv	CV	Max.	Min.	Mean	Sdv	CV	Max.	Min.	Mean	Sdv	CV	Max.	Min.
1.000	0.006	0.006	1.022	0.971	1.000	0.006	0.006	1.021	0.976	0.999	0.005	0.005	1.028	0.981

From the results shown in Figure 5-8 and Table 5-7, the observed sensitivity (ratio) regarding the various wave-induced responses at the probability levels 10^{-8} could be summarised as follows:

- The mean values of the ratios of the eight wave-induced responses are very close to 1.00.
- The standard deviations of the ratios regarding the eight wave-induced responses are about 0.005 to 0.006.

As the sensitivity (ratio) to ship speeds regarding various wave-induced responses is very limited and small, it could be concluded that to use 5 knots as the ship speed for the extreme wave loads for strength assessment as indicated in the TB-CSR [3] is appropriate and reasonable for Rec.34 v2.

The roll related responses of container ships are excluded from Figure 5-8 because the accuracy of the roll motion for container ships based on the linear strip theory used in this study is not satisfactory. It should be noted that appropriate speed and viscous damping need to be applied when evaluating roll related responses by numerical simulations for vessels with very low metacentric height and operating without reduced speed in stern quartering seas. It is assumed that these effects are considered in the development of rule formulae of roll motions by individual classification society.

5.5 Design lifetime and ship speed for fatigue assessment

The design lifetime for strength and fatigue assessments, the ship speed used for evaluating wave loads for fatigue assessment and the probability level selected for wave loads for fatigue assessment have been investigated in PT PH40.

Regarding the design lifetime for strength and fatigue assessments, twenty-five years, which has been already used in the TB-CSR [3] is recommended in order to satisfy the IMO GBS requirement Tier II [4]. Consequently, a return period of twenty-five years is recommended for evaluating the extreme design wave loads for the strength assessment. The return period of a value X_{RP} can be formally defined by $P(x < X_{RP}, RP) = 1/e$, i.e. the non-exceedance probability of the extreme (at $RP=25$ years) in 25 years is 36.8%.

Moreover, 3/4 of the design speed is recommended for evaluation of the design wave loads for the fatigue assessment in the Rec.34 v2, which is corresponding to that used in the TB-CSR [3]. The probability distributions of different relative ship speeds regarding H_s based on the combined AIS and hindcast dataset mentioned above in 5.1 is shown in Figure 5-9. It can be seen that the most probable relative speed for moderate sea states is indeed 3/4 of the design speed.

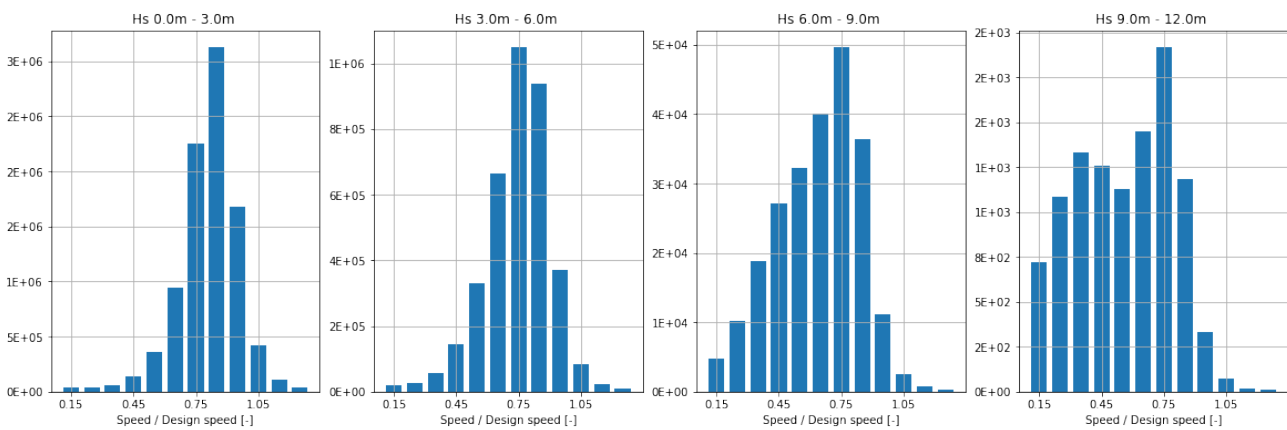

Figure 5-9 Probability distributions of different relative speeds to H_s

Furthermore, the design wave loads at the probability level of 10^{-2} are selected for the fatigue assessment as the reference value to derive their long-term prediction distributions for fatigue assessment in Rec.34 v2, which follows the same consideration used in the TB-CSR [3].

5.6 Limitations

Whilst the studies, techniques and data used by IACS to contribute to the up-issue of Rec.34 are considered state-of-the-art, there are limitations and these are highlighted here.

5.6.1 Wave models

IACS Rec.34 v2 relies heavily on synthetic hindcast data. Although those have been validated through comparison with satellite altimeters, some uncertainties with this technology can be expected for all relevant derived parameters including wave height, period and direction. It can also be noted that moored buoys used for validation of the altimeters are themselves only present at the Atlantic basin margins, so there could be a bias present. In coming years, drifting buoys may fill this gap in the central ocean.

Wave modelling is an active academic field and the accuracy of the global wave models is expected to continue to improve year on year.

5.6.2 Climate change

The updated wave environment recommendations proposed by IACS are a present day snapshot and do not include any climate forecast change effects. This might be considered a limitation, but has been disregarded for reasons given here:

Reviewing the relevant literature on climate change mainly coming from the sessions of the Intergovernmental Panel on Climate Change (IPCC), it was observed that there was a great deal of uncertainty about the effects relevant to shipping. Long term *hindcasting* using the atmospheric models is hampered by the lack of reliable measured data over long time scales. Long term *forecasting* is hampered by lack of confidence in the scenarios themselves, particularly the wind models used to drive the forecasts. However, even changes at the highest end of IPCC projections of +/- 0.5m (positive or negative) in extreme and average wave heights for the North Atlantic would be expected to have negligible effect on the Rec.34 v2 scatter diagram due to the robustness of the derivation procedure. Furthermore, since even under extreme wave environment changes due to climate change, ships in service will continue to avoid rough weather at the levels encapsulated in the new scatter diagram. In effect the Rec.34 v2 scatter diagram does include some future-proofing.

5.6.3 Bad weather avoidance

The bad-weather avoidance embedded within this work represents the current performance level of global shipping. The technical quality, availability and take-up of routing services is increasing under current industry drive towards digitalisation. Therefore, the new recommendation might be regarded as including a slightly conservative bias as time goes on and those improvements become more definite.

5.6.4 Statistics

Synchronised weather data with ship position was limited to only 7 years. This was compensated by the fact that a huge number of ship positions was used, roughly 4500 ship-years, and that these later years were among the roughest recorded. It is theoretically possible to improve the scatter diagram derivation by 'de-clustering' the data to remove sampling effect, but that would not be a trivial exercise. IACS considers the amount of data used is sufficient to correctly assess the 25 years ship responses, though this limitation is to be kept in mind when using the proposed scatter-diagram to estimate response at very lower probabilities (i.e. very higher return period). Even so, the new scatter diagrams are considered a huge improvement on Rec.34 v1 derived from eyeball observations.

Finally, it might be considered the industry standard design approach using scatter-diagram is itself a limitation to design success. Recent research shows that by grouping time-series data into Hs-T0m1 bins, the serial correlation of sea-states is lost and an overestimation bias about 5% on VBM is possible for large vessels. It is to be seen whether these practices become adopted.

5.7 References

- [1] de Hauteclocque, G., Zhu, T., Johnson, M., Austefjord, H. and Bitner-Gregersen, E. "Assessment of Global Wave Datasets for Long Term Response of Ships". Proceedings 39th International Conference on Ocean, Offshore and Arctic Engineering, ASME OMAE2020, Fort Lauderdale, FL, USA, 2020.
- [2] de Hauteclocque, G. and Lasbleis, M. "Extreme seastate parametrization and its consequences on ship responses", 15th International Symposium on Practical Design of Ships and Other Floating Structures PRADS 2022, Dubrovnik, Croatia, October 9th-13th 2022.
- [3] IACS, "Common Structural Rules for Bulk Carriers and Oil Tankers, Technical Background Rule Reference," PT01, 2019.
- [4] IMO, "Adoption of the International Goal-Based Ship Construction Standards for Bulk Carriers and Oil Tankers", 2010.
- [5] Hersbach H. et al, "The ERA5 global reanalysis", Quarterly Journal of the Royal Meteorological Society, 146(730):1999–2049, 2020.

6. Attachments if any

None

Recommendation No. 35 “Inspection and Maintenance of Electrical Equipment Installed in Hazardous Areas for Ships other than Tankers”

Summary

In Rev.2 of this Recommendation, the way to refer to instruments other than those specified by IACS was unified.

Part A. Revision History

Version no.	Approval date	Implementation date when applicable
Rev.2 (Feb 2021)	15 February 2021	-
Corr.1 (June 2015)	04 June 2015	-
Rev.1 (Mar 2006)	March 2006	-
New (1992)	1992	-

- **Rev.2 (Feb 2021)**

1 Origin of Change:

- Other (Update to comply with the required format when industry standards are referred to)

2 Main Reason for Change:

There was a need to update this recommendation to comply with the following format when industry standards are referred to:

[Standard Designation], [version/revision, if applicable], [year of publication]
(examples: API Spec 2F, 6th Edition, 1997; ISO 4624, 2002), where
[version/revision, if applicable] and/or [year of publication] are decided by IACS
and are not necessarily to be the current/latest version.

3 List of non-IACS Member classification societies contributing or participating in IACS Working Group:

None

4 History of Decisions Made:

None

5 Other Resolutions Changes:

None

6 Any hinderance to MASS, including any other new technologies:

None

7 Dates:

Original Proposal: 28 October 2019 (Ref: PM18939_IMd)
Panel Approval: 9 November 2020 (Ref: PM20906_IMf)
GPG Approval: 15 February 2021 (Ref: 20206bIGb)

• **Corr.1 (June 2015)**

.1 Origin of Change:

Suggestion by an IACS Member

.2 Main Reason for Change:

This task is triggered to coordinate IACS Rec 35 with the new Rec 120 "Survey of electrical equipment installed in hazardous areas on tankers" being developed under PM5408.

.3 List of non-IACS Member classification societies contributing through the TC Forum and/or participating in IACS Working Group:

None

.4 History of Decisions Made:

This is a follow-up task of PM5408. Machinery Panel decided to issue the draft Rec 120 "Survey of electrical equipment installed in hazardous areas on tankers" being developed under PM5408 as a separate Recommendation applying to tankers and also to keep Rec 35 concurrently.

At the 19th Panel Meeting held in March 2014, Machinery Panel concurred to re-phrase the title of Rec 35 to make the document standalone and independent from Rec 120 being developed under PM5408. On the grounds of this, Machinery Panel unanimously agreed to add "for ships other than tankers" at the end of the title, i.e. '*Rec 35 Inspection and Maintenance of Electrical Equipment Installed in Hazardous Areas for Ships other than Tankers*'.

.5 Other Resolutions Changes

Rec 120 (New, June 2015)

.6 Dates:

Original Proposal: 5 July 2010 Made by a Member
Panel Approval: 14 May 2015
GPG Approval: 04 June 2015 (Ref: 5029bIGm)

- **Rev.1 (Mar 2006)**

No history file or TB document available.

- **New (1992)**

No history file or TB document available.

Part B. Technical Background

List of Technical Background (TB) documents for Recommendation 35:

Annex 1. **TB for Rev.2 (Feb 2021)**

See separate TB document in Annex 1.



Note: *There are no separate Technical Background (TB) documents available for Original version (1992), Rev.1 (Mar 2006) and Corr.1 (June 2015).*

Technical Background (TB) document for Rec 35 (Rev.2 Feb 2021)

1. Scope and objectives

Recommendation No. 35(Rev.1) does not reflect the agreed format for referencing the IEC standards. Rev.2 has been developed to comply with the agreed format.

2. Engineering background for technical basis and rationale

Format for references to Industry standards

Format:

[Standard Designation], [version/revision, if applicable], [year of publication]
 (examples: *API Spec 2F, 6th Edition, 1997; ISO 4624, 2002*), where
[version/revision, if applicable] and/or [year of publication] are decided by IACS and are not necessarily to be the current/latest version.

3. Source/derivation of the proposed IACS Resolution

None

4. Summary of Changes intended for the revised Resolution:

Recommendation No. 35 has been updated to specify the revision/version of the IEC standards as follows:

IEC standards	Replaced by
IEC 60079-17	IEC 60079-17:2013

5. Points of discussions or possible discussions

None

6. Attachments if any

None

Recommendation No.36 “Recommended procedure for the determination of contents of metals and other contaminants in stern tube lubricating oil”

Summary

Revision 3 clarifies the requirements related to oil aging so as to specify that the limits for Total Acid Numbers (TAN) are to be based upon values defined by oil makers.

Part A. Revision History

Version no.	Approval date	Implementation date when applicable
Rev.3 (Nov 2020)	12 November 2020	-
Rev.2 (Aug 2011)	05 August 2011	-
Rev.1 (1997)	12 May 1997	-
New (1992)	No records	-

- **Rev.3 (Nov 2020)**

1 Origin of Change:

Select a relevant option and delete the rest.

Suggestion by IACS member

2 Main Reason for Change:

The reason to amended item 5 of Rec.36 (Rev.2) is to clarify requirements related to oil aging so as to specify that the limits for Total Acid Numbers (TAN) are to be based upon values defined by oil makers.

The necessity for providing the above clarification was identified while answering the industry’s queries regarding oil aging. For more information, kindly refer to the Part B Annex 1 “Technical Background” of this document.

3 List of non-IACS Member classification societies contributing or participating in IACS Working Group:

None

4 History of Decisions Made:

None

5 Other Resolutions Changes:

None

6 Any hinderance to MASS, including any other new technologies:

None

7 Dates:

Original Proposal: July 1 2020 (Made by: Machinery Panel)
Panel Approval: 27 October 2020 (Ref: 20173_PMa)
GPG Approval: 12 November 2020 (Ref: 20173_IGb)

• **Rev.2 (Aug 2011)**

1 Origin of Change:

Select a relevant option and delete the rest.

Other (*Task of reviewing Recommendations to be posted on the web*)

2 Main Reason for Change:

In the course of fulfilling the task of reviewing Recommendations to be posted on the web, the Machinery Panel Chairman submitted the revised Rec.36, which has been agreed by the Machinery Panel Members (PM5901c).

3 List of non-IACS Member classification societies contributing or participating in IACS Working Group:

None

4 History of Decisions Made:

GPG agreed to the draft Recommendation submitted by the Machinery Panel, as wellas to the proposal of a Machinery Panel Member to delete the Note in para.1 "Note :It is recommended to take lubricating oil sample and carry out analysis once in every month" for it's not according with Z21.2(d)"Where a lubricating oil analysis is carried out regularly at intervals not exceeding six months, and the oil consumption and bearing temperature are recorded and considered to be within permissible limits, drawing of the shaft to expose the aft bearing contact area of the shaft may not be required."

5 Other Resolutions Changes:

None

6 Any hinderance to MASS, including any other new technologies:

None

7 Dates:

Original Proposal: 11 July 2011, made by Machinery Panel
GPG Approval: 05 August 2011 (Ref: 0140bIGi)

- **Rev.1 (1997)**

The word "shaft" in the title changed to "stern tube". The title of section 3 changed to "Contaminants determination". Metal and water content values in section 4 are refined as "Suggested upper limits".

- **Original document (1992)**

No records are available.

Part B. Technical Background

List of Technical Background (TB) documents for Rec.36:

Annex 1. **TB for Rev.3 (Nov 2020)**

See separate TB document in Annex 1.



There are no separate Technical Background (TB) documents available for Rec.36 (New 1992), Rev.1 (1997) and Rev.2 (Aug 2011)

Technical Background (TB) document for Rec 36 (Rev.3 Nov 2020)

1. Scope and objectives

With regard to the requirement for oil aging in item 5 of Rec. 36(Rev.2), following inquiries from a relevant industry member were received;

1. What problems (failure, damage, etc.) may arise in cases where oil is found to be "abnormal" based upon the observation of trends in TAN, viscosity and changes in colour etc.?
2. In cases where environmentally adapted lubricants are used, can the same problems arise or can other problems arise?

IACS' Machinery Panel deliberated on the above inquiries and answers to the above inquiries are given in para 2 below. Further based on the answers, it was considered necessary to amend the item 5 in Rec.36 (Rev.2) with the aim to clarify the requirements for oil aging so as to specify that the limits for Total Acid Numbers (TAN) are to be based upon values defined by oil makers.

2. Engineering background for technical basis and rationale

By observing the TAN, viscosity and oil appearance of traditional mineral oils used to lubricate stern tubes, the oxidation and ageing of the lubricant, including its additive package, can be assessed to determine whether the lubricant is still fit for further use. Excessive oxidation will typically lead to lubricant colour becoming darker, which may in turn also indicate an increase in TAN or viscosity; on the other hand, water contamination may cause the lubricant to appear hazy or cloudy. It is, therefore, important to assess all concerned parameters together as a whole since a change in only one of them can be an indication of other problems, e.g. topping-up with the wrong lubricant can result in viscosity variations. Oxidation and an increase in TAN can be further accelerated if water is present, i.e. from the generation of organic acids, and consequential issues like shaft corrosion and bearing/seal failure might occur if the lubricant is not maintained to be fit for purpose.

In addition to the same problems experienced by mineral oils, it should be noted that environmentally acceptable lubricants are also susceptible to hydrolysis and microbial contamination. Hydrolysis is lubricant degradation due to water contamination. For ester-based EALs (Environmentally Acceptable Lubricants), hydrolysis will lead to acidity increases that can be detected through the observation of TAN. Microbial contamination can be caused by micro-organisms, bacteria, mould, yeasts, fungi, biomass and biofilm for which specialist testing is required to enable accurate identification.

Both normal fresh lubricant TAN levels (base level) and attention/alarm levels will vary by product, and consequential issues like shaft corrosion and bearing/seal failure might occur if the lubricant is not maintained to be fit for purpose.

3. Source/derivation of the proposed IACS Resolution

None

4. Summary of Changes intended for the revised Resolution:

None

5. Points of discussions or possible discussions

None

6. Attachments if any

None

Recommendation No.38 “Guidelines for the Survey of Offshore Mooring Chain Cable in Use”

Summary

The revision 2 updates and/or identifies the versions of industry standards referenced in Rec. 38.

Part A. Revision History

Version no.	Approval date	Implementation date when applicable
Rev.2 (July 2020)	17 July 2020	-
Rev.1 (Oct 2010)	13 Oct 2010	-
New (1995)	1995	-

• Rev.2 (July 2020)

.1 Origin of Change:

- GPG 85 FUA 10 (update of references to Industry Standards)

.2 Main Reason for Change:

The main technical reason for the change is to update the references to Industry Standards.

.3 List of non-IACS Member classification societies contributing or participating in IACS Working Group:

None

.4 History of Decisions Made:

The revisions were made through discussions and e-mails within the Hull Panel and consultation with EG M&W. Hull Panel Chair incorporated the comments and drafted a final revision. Hull Panel members reviewed and accepted the revision.

.5 Other Resolutions Changes

None

.6 Any hinderance to MASS, including any other new technologies:

None

.7 Dates:

Original Proposal: 19 June 2020 (Made by Hull Panel Chair)
Panel Approval: 01 July 2020 (Ref: 19000_PHc)
GPG Approval: 17 July 2020 (Ref: 19000_IGm)

• **Rev.1 (Oct 2010)**

.1 Origin of Change:

Suggestion by an IACS member

.2 Main Reason for Change:

The main technical reason for the change is to update the recommendation in order to take into account current practice.

.3 List of non-IACS Member classification societies contributing through the TC Forum and/or participating in IACS Working Group:

When the revision first started IRS was an associate member. However, by the time it was finished, IRS has become a member of IACS.

.4 History of Decisions Made:

The revisions were made through discussions and e-mails within the Hull Panel. A Hull Panel Member incorporated the comments and drafted a final revision. Hull Panel members reviewed and accepted the revisions.

.5 Other Resolutions Changes

None

.6 Dates:

Original Proposal: *30 November 2007 Made by Hull Panel Member*
Panel Approval: *10 September 2010*
GPG Approval: *13 October 2010 (Ref: 10127_IGc)*

Part B. Technical Background

List of Technical Background (TB) documents:

Annex 1 **TB for Rev.1 (Oct 2010)**

See separate TB document in Annex 1.



Note: There are no separate Technical Background (TB) document available for New (1995) and Rev.2 (July 2020).

Technical Background for Recommendation No.38 Rev.1 (Oct 2010)

1. Scope and objectives

The revision is made to update the recommendation in order to take into account current practice. It includes specific information on the wear-down and movement of mechanical locking for use while conducting surveys on offshore mooring chain. The intent is to assist with consistent application of the recommendation.

2. Engineering background for technical basis and rationale

The main basis for the change is to simply take into account current practice. It is noted that satisfactory in-service performance has been experienced and this change represents an improvement to the documentation on what is applied.

3. Source/derivation of the proposed IACS Resolution

The source of the information was obtained through the input of the Hull Panel members.

4. Summary of Changes intended for the revised Resolution:

Editorial changes are made as well as some clarifications to specific information on the number of samples, the wear-down measurements and movement of mechanical locking for use while conducting surveys on offshore mooring chain.

5. Points of discussions or possible discussions

The revisions were made through discussions and e-mails within the Hull Panel which involved mainly incorporating individual comments and accepting the consolidated text.

6. Attachments if any

None.

Technical Background

Recommendation 39, Rev.3 – March 2009

Survey Panel Task 1: *Amendments to Recommendation 39 – Concerns related to Rule changes regarding rafting*

1. Objective

Amend the Recommendation 39 for removing impracticality and risks in using rafts when surveyors survey cargo tanks.

2. Background

One member of IACS Survey Panel received an advice from field staff, which described concerns about an accident which can happen when water level is falling while surveyors are surveying cargo tanks using a raft. The advice from field staffs also introduced accidents which occurred due to air pockets in the water during deballasting operation. Field staff recommended that the level shall be stationary and the ballast system should be isolated to prevent any accidental ingress or outflow of water and pointed out that their rule, which states ‘The surface of water in the tank is to be calm and the water level either stationary or falling’, should be amended. The field staff also pointed out that the water level, which is provided to be allowed within 1 m of the deepest under deck web face flat, should be changed to be allowed within 0.5m. The reason for this is that, if we consider the web is allowed to be maximum 1.5m deep in case of bad coating condition, the distance for close up survey of the under deck structure is too much for most surveyors to reach it by hand. Based on above technical grounds, field staff asked if any amendments to UR Z10.1 and Recommendation No. 39 can be made.

3. Discussion

In the 8th Survey Panel meeting, Chairman, explained about the impracticality in using rafts when surveying cargo tanks - i.e., danger of air pockets when de-ballasting, impractical distance for reaching by hand, and height for easy maneuverability of raft. Also the relevant Panel member explained about the correspondence regarding ‘Concerns related to Rule changes regarding rafting’ which was sent by a field staff. Upon discussion, members consented to the first proposal on water level but not to the second part on the distance under deck. At the end, it was concluded that first one can be changed, but second one should remain unchanged. Members agreed to amend IACS Recommendation 39, 1.4 d) by removing “either” ... “or falling” from the first sentence.

Submitted by Survey Panel Chairman
25 February 2009

Permanent Secretariat note (March 2009):

Rec.39 Rev.3 was approved by GPG on 18 March 2009 (ref. 9528_IGb).

Recommendation No. 41 "Guidance for Auditors to the ISM Code"

Summary

- This revision is to harmonize the terms of 'recommendation' and 'condition of class' with only the term 'condition of class' being retained.
- This revision has been developed to align the Rec. with resolutions MSC.273(85) and MSC.353(92), incorporate "Guidelines for SMC, ISSC and MLC expiration dates alignment" in new Annex 5 and introduce new "Guidance on Interim Audits" in new Annex 6.

Part A. Revision History

Version no.	Approval date	Implementation date when applicable
Rev.5 (Oct 2019)	7 October 2019	-
Corr.1 (Oct 2016)	-	-
Rev.4 (Dec 2005)	1 December 2005	-
Rev.3 (June 2005)	2 June 2005	-
Rev.2 (1999)	24 February 1999	-
Rev.1 (1997)	10 December 1997	-
New (1996)	1996	-

Rev.5 (Oct 2019)

.1 Origin of Change:

- Suggestion by IACS member
- Based on IMO Resolutions (*MSC.273(85) and MSC.353(92)*)
- Other (*Members operational experience*)

.2 Main Reason for Change:

- Review and amendment in line with ISM Code amendments and based on Members' operational experience.
- Introduction of the policy decision made by GPG to use common terminology "Condition of Class" (CoC) instead of the terms "Recommendation/Condition of Class" based on the outcome of III 5.

.3 List of non-IACS Member classification societies contributing through the TC Forum and/or participating in IACS Working Group:

None

.4 History of Decisions Made:

- During the 29th panel meeting, the panel discussed about the comments of members, and concurred with the view to retain the present definitions of CoC in the IACS resolutions with the wording 'Recommendation' to be removed. The panel also agreed to use the term 'Statutory Condition' for the 'recommendation' of the statutory certificates in IACS resolutions and RECs, and when discussing the proposal of a member to consider the harmonization of the terms of 'recommendation' and 'condition of class' in RO Code, the panel unanimously agreed to take no action on the IMO instruments, leaving the relevant actions to be decided by the relevant IMO bodies when IACS feeds back to IMO the IACS action on the harmonization of the two terms.

Panel members concurred with the view that it is not necessary to develop a new procedure requirement, and agreed to set the implementation date of these IACS resolutions (other than RECs) as 1st July 2020.

Before the implementation date of 1st July 2020 for using the common terminology 'Condition of Class' only, 'Recommendations' and 'Condition of Class' are to be read as being different terms used by Societies for the same thing, i.e. requirements to the effect that specific measures, repairs, surveys etc. are to be carried out within a specific time limit in order to retain Classification.

No TB is expected for the present revision.

- In June 2015 during the 1st meeting of EG/ISM-ISPS-MLC (after the merger of EG/ISM-ISPS and EG/ILO) the group decided to review and agree on amendments to Rec.41 related to the amendments to the ISM Code as already drafted by the small working group established during the last EG/ISM-ISPS meeting in December 2014. It was also decided that the agreed amendments will be included in the master document of Rec.41, which was under development by a Member and further changes to the document will be discussed by correspondence.

In June 2016 during EG/MS 2nd Meeting an EG/MS Member presented actual status of this Recommendation. The document was almost complete and ready – the main work left was formatting of the text using IACS template. It was agreed that the Chairman will request IACS Permsec for providing the last Word version of the Rec41.

After formatting additional corrections and comments were discussed by correspondence.

.5 Other Resolutions Changes:

- The following IACS resolutions and Recommendations (RECs) were agreed to be revised:

- Procedural Requirements: PR1A, PR1B, PR1C, PR1D, PR1 Annex, PR3, PR12, PR20, PR35 and the attachment of PR16;
- Unified Requirements: Z7, Z7.1, Z7.2, Z10.1, Z10.2, Z10.3, Z10.4, Z10.5, Z15 and Z20

Rev.4 (Dec 2005)

GPG/Council decided that Annex 5 of Recommendation No.41 was to be deleted, because:

- 1) It contained information that were not relevant to ISM audits as well as statements that might even be misleading; and
- 2) The frequent updating and maintenance required of Annex 5 would not be worth the considerable effort involved.

Rev.3 (June 2005)

Subject no 4081e

SHG/ISMC Task 2002-03. Submitted to GPG 17/20/12/04 by 4081eKR.a.

Rev.2 (1999)

AHG/ISMC has been tasked to develop a Guideline for Y2K issue with a target completion by 1Q-99. It will be annexed to Rec.41. On 14/1/99, AHG chairman submitted the draft with a remark that this Guidelines should be subject to continual review in light of future changes to industry guidelines.

Rev.1 (1997)

Improvement of the Recommendation 41 by reflecting experience gained during the past years.

New (1996)

No Records Available.

Part B. Technical Background

List of Technical Background (TB) documents for Rec41:

Note:

There are no separate Technical Background (TB) documents for New (1996), Rev. 1 (1997), Rev.2 (1999), Rev.3 (June 2005), Rev 4 (Dec 2005), Corr. 1 (Oct 2016) and Rev.5 (2019).

Recommendation No.42

“Guidelines for Use of Remote Inspection Techniques for surveys”

Part A. Revision History

Version no.	Approval date	Implementation date when applicable
Rev.2 (June 2016)	22 June 2016	-
Rev.1 (May 2004)	26 May 2004	-
New (1996)	-	-

• Rev. 2 (June 2016)

.1 Origin of Change:

- Suggestion by IACS member

.2 Main Reason for Change:

As outcome of the discussion held under Panel Task PSU14020, related to the possible use for the remote techniques of surveys for the close up surveys of the ships subjected to ESP regime, the revision of the IACS Recommendation 42 was proposed. The revision is included among the permanent tasks assigned to the Panel according to IACS Procedure.

.3 List of non-IACS Member Classification Societies contributing through the TC Forum and/or participating in IACS Working Group:

None

.4 History of Decisions Made:

Panel Members, by considering the advances made in the field of remote inspection techniques during the last 10 years (such as non-invasive inspection performed by miniaturized cameras), approached the revision of the recommendation under panel task PSU16005.

During the 23rd Survey Panel meeting the various proposals have been discussed and the text revision 2 of the Recommendation was agreed by the members.

It is worth to note that:

- 1) The list of the remote inspection techniques more frequently used in the marine field has been introduced;
- 2) The inspection fields have been enlarged by adopting the concept of the “Item to be inspected” which, in turn, encompasses the hull structures as well as internal inspection of machinery items and equipment.

Members discussed the possibility to adopt the remote inspection techniques as a possible support to the close up surveys of the ships subjected to the ESP Code (Oil Tankers and Bulk Carriers). The Panel concluded that since the ESP Code is matter of statutory duties, the use of remote inspection techniques shall be authorized by the Flag Administration.

No technical background has been expected for this revision.

.5 Other Resolutions Changes:

None

.6 Dates:

Original Proposal: 03 February 2016, Made by: IACS member
Panel Approval: 16 March 2016 (Ref: PSU16005)
GPG Approval: 22 June 2016 (Ref: 16103_IGb)

- **Rev. 1 (May 2004)**

GPG Approval: 26 May 2004 (Ref: 4053_).

- **New (1996)**

No records available.

Part B. Technical Background

List of Technical Background (TB) documents for Rec. 42:

Note:

1) There are no separate Technical Background (TB) documents for Recommendation No.42 New (1996), Rev.1 (May 2004) and Rev.2 (June 2016).

Recommendation No.46

“Guidance and Information on Dry Cargo Loading and Discharging to Reduce the Likelihood of Over-stressing the Hull Structure”

Summary

The revision 2 of the Rec.46 has been updated for improving some aspects linked to operational aspects (flooded conditions, Mass curves, side frame stresses when top side tanks are full in loading conditions with high density cargoes, etc).

Part A. Revision History

Version no.	Approval date	Implementation date when applicable
Rev.2 (Jan 2020)	31 January 2020	-
Rev.1 (July 2018)	16 July 2018	-
New (1997)	1997	-

- **Rev.2 (Jan 2020)**

1 Origin of Change:

Other: *Comments made by INTERCARGO*

2 Main Reason for Change:

Improvement of the IACS past publications regarding the UR S, of figures for permissible SWBM and SF in flooded situation, for mass curves, for block loading, of adverse influence of the top side tanks filling on side frames in loading conditions with high density cargoes.

3 List of non-IACS Member classification societies contributing through the TC Forum and/or participating in IACS Working Group:

None

4 History of Decisions Made:

The comments made by INTERCARGO on the Rev.1 were discussed on 6 Nov 2019 for improving the text.

5 Other Resolutions Changes:

None

6 Any hinderance to MASS, including any other new technologies:

None

7 Dates:

Original Proposal: 06 November 2019 Made by: Hull Panel Chair
Panel Approval: 13 December 2019 (PH17030_IHaa)
GPG Approval: 31 January 2020 (Ref: 17110aIGm)

• Rev.1 (July 2018)

.1 Origin of Change:

- Based on IACS Requirement (Updated according to CSR)

.2 Main Reason for Change:

GPG tasked the Hull Panel to review the list of IACS recommendations under the Panel responsibility and to advise the ones relevant to ship/port interface operations. Rec. 46 has been identified as being part of this scope.

Since Rec. 46 current revision has been published in 1997, it has been noticed that the recommendation needed to be updated with the current operational practices, latest International regulations and IACS developments coming from the Common Structural Rules (both CSR BC and the harmonized CSR BC and OT).

.3 List of non-IACS Member Classification Societies contributing through the TC Forum and/or participating in IACS Working Group:

None

.4 History of Decisions Made:

The Hull Panel using the SharePoint platform reviewed the Rec.46 including the text content, the document format, IACS address, acknowledgement, disclaimer and back cover.

The Rec.46 text content has been updated in view of including IACS latest developments coming from the Common Structural Rules (both CSR BC and the harmonized CSR BC and OT).

Some technical terms were updated according to the terms currently used by industry and editorial corrections have been introduced where found necessary.

A new paragraph has been introduced highlighting the risks related to cargo liquefaction.

International regulations have been updated accordingly i.e. the Ballast Exchange section.

.5 Other Resolutions Changes:

None

.6 Dates:

Original Proposal: 21 February 2018 Made by: Hull Panel
Panel Approval: 25 June 2018 (Ref: PH17030_IHi)
GPG Approval: 16 July 2018 (Ref: 17110_IGk)

- **New (1997)**

No history files or TB document available.

Part B. Technical Background

List of Technical Background (TB) documents for Rec.46:



Note: *There are no separate Technical Background (TB) documents for New (1997), Rev.1 (July 2018) and Rev.2 (Jan 2020)*

Recommendation No.47 "Shipbuilding and Repair Quality Standard"

Summary

Review and update industry standard format according to GPG instructions.

Part A. Revision History

Version no.	Approval date	Implementation date when applicable
Rev.10 (Sep 2021)	21 September 2021	
Rev.9 (June 2021)	22 June 2021	
Rev.8 (Oct 2017)	15 October 2017	
Rev.7 (June 2013)	19 June 2013	
Rev.6 (May 2012)	12 May 2012	
Rev.5 (Oct. 2010)	06 Oct 2010	
Rev.4 (Aug. 2008)	04 Aug 2008	
Rev.3 (Nov. 2006)	01 Nov 2006	
Rev.2 (Dec. 2004)	12 Dec 2004	
Rev.1 (Aug. 1999)	17 Aug 1999	
New (1996)	15 Nov 1996	

• Rev. 10 (Sep 2021)

.1 Origin of Change:

- Suggestion by IACS member

.2 Main Reason for Change:

To update industry standards format according to GPG instructions given in GPG Vice-chair message 19000_IRC.

.3 List of non-IACS Member classification societies contributing and/or participating in IACS Working Group:

None

.4 History of Decisions Made:

Original proposal was made according to GPG Vice-chair message 19000_IRC. Proposal to revise the IACS URs and RECs only to refer to a dated version of the industry standard as per GPG instructions was made at IACS EG/MW meeting in September 2019. Three drafts have been discussed by the EG/MW group.

No TB is expected for the present revision.

.5 Other Resolutions Changes:

None

.6 Any hinderance to MASS, including any other new technologies:

None

.7 Dates:

Original Proposal	: April 2019	(Ref: 19000_IRc, made by GPG)
EG M&W Approval	: July 2021	(Ref: 1910_EMWo)
GPG Approval	: 21 September 2021	(Ref: 19000_IGq)

• Rev. 9 (June 2021)

.1 Origin of Change:

- Based on IACS Requirement (UR W33 being newly adopted, with Recommendation 20 being deleted)

.2 Main Reason for Change:

Upon the approval of the newly developed UR W33, NDT for ship hull steel welds, Recommendation 20 is to be deleted, the relevant content in Rec. 47 should be also updated.

.3 List of non-IACS Member classification societies contributing or participating in IACS Working Group:

None

.4 History of Decisions Made:

Survey Panel agreed to replace the term "Recommendation 20" with "UR W33" throughout Rec.47.

Survey Panel further identified that upon the deletion of Rec.12 and entry into force of Revision 9 of UR W11, relevant content of Rec.47 should be also updated, and agreed to replace the term "Recommendation 12" with "UR W11" throughout Rec.47.

To be aligned with the decision for Revision 1 of UR W33, all "NDE" terms were switched to "NDT".

No TB is expected for the present revision.

.5 Other Resolutions Changes:

None

.6 Any hinderance to MASS, including any other new technologies:

None

.7 Dates:

Original Proposal: December 2019 Made by GPG (Ref: 13202_IGzh)
Panel Approval: 4 May 2021 (Ref: PSU19045)
GPG Approval: 22 June 2021 (Ref: 13202_IGzv)

• **Rev 8 (Oct 2017)**

.1 Origin for Change:

Other (Query from industry - FR. LÜRSEN WERFT GmbH & Co. KG)

.2 Main Reason for Change:

The main change relates to update information of Table 4.2 of Part B of IACS Recommendation No.47. The reason for this is to revise standard references, and, the nomenclature of some steel grade becomes obsolete.

.3 List of non-IACS Member Classification Societies contributing through the TC Forum and/or participating in IACS Working Group:

None.

.4 History of Decisions Made:

Original proposal was triggered by Permsec in light of the message submitted on 15 July 2016 by FR. Lürssen werft GmbH&Co. KG representative. Form A with task Number EMW1608 was agreed at IACS EG/MW meeting in September 2016 and noted by GPG in 26 September 2016. Two drafts have been discussed by the group, final draft was agreed by EGMW in June 2017.

.5 Other Resolutions Changes

None.

.6 Dates:

Original Proposal : 15 June 2016 Made by: from Industry
EG M&W Approval : 11 August 2017 (Ref: EMW1608)
GPG Approval : 15 October 2017 (Ref: 16172_IGd)

• **Rev.7 (June 2013)**

1 Origin for Change:

Suggestion by IACS Members

.2 Main Reason for Change:

During discussion of an outside inquiry regarding the alignment of a t-longitudinal in Table 9.1, the Panel decided to review IACS Rec.47 against other standards currently followed by shipyards and accordingly, if necessary, update IACS Rec.47.

.3 List of non-IACS Member classification societies contributing through the TC Forum and/or participating in IACS Working Group:

None

.4 History of Decisions Made:

A Panel member suggested that Rec 47 should be revised since Rec 47 differs from other shipyard standards with respect to the alignment of a t-longitudinal as shown in Table 9.1. The Panel reviewed the standard practice of different shipyards and agreed to revise the text "grind corners to smooth taper over a distance of 50a" into "release and adjust over a distance of 50a".

A Member suggested that the bending radius given in Table 6.3 for corrugated bulkheads should be amended as per the provision of the CSR Tanker Rules, Sec. 6/4.2.2. The Panel agreed to put this requirement in Rec. 47 for CSR ships only.

The Panel also discussed existing requirements on welding and grinding of cracks in Part B of Section 6.8/6.9. The Panel included introductory text in Section 6.8(Welding repairs for cracks) to clarify this section and agreed to delete section 6.9 (Grinding of shallow cracks) considering that this section is not relevant for a repair standard of existing vessels.

.5 Other Resolutions Changes

None

.6 Dates:

Survey Panel Approval: 21 February 2013
GPG Approval: 19 June 2013 (Ref: 13085_IGd)

• Rev.6 (May 2012)

.1 Origin of Change:

- Other (Based on Other Standard (SSC-443))

.2 Main Reason for Change:

Revise the Recommendation 47 with reference to SSC-443 and in light of experience gained so far for the use of doubling plates for ships in operation.

Also, references and titles of Rec 20, UR W13 and UR W14 were to be updated to current document titles.

.3 List of non-IACS Member classification societies contributing through the TC Forum and/or participating in IACS Working Group:

None

.4 History of Decisions Made:

The Task was triggered by GPG in light of the document SSC-443 by the Ship Structure Committee (U.S.A.) following a bilateral message of 11/1/11 from a Member. The expected benefit of undertaking the work was to have a technical discussion on the use of doublers aboard ship leading to a review of aspects of Recommendation 47 relating to doublers with a view to improving and enhancing current guidance in the Recommendation. Priority was given to discussion of the document SSC-443 vis-à-vis current IACS recommendations regarding doublers.

.5 Other Resolutions Changes

None

.6 Dates:

Original Proposal: *20 January 2012 Made by: Survey Panel*
Panel Approval: *20 April 2012*
GPG Approval: *12 May 2012 (Ref: 11020_IGh)*

• Rev.5 (Oct 2010)

.1 Origin of Change:

- Other (Query from industry - DAEWOO SHIPBUILDING & MARINE ENGINEERING CO.,LTD.)

.2 Main Reason for Change:

It was agreed in the Panel that the acceptance criteria for minor imperfections is not clear without the definition of influenced area. The existing text is not in line with international standards which are applied by many shipyards and manufacturers. And the definition of limit gap between plates for butt welding is obscure in the relevant Table.

.3 List of non-IACS Member classification societies contributing through the TC Forum and/or participating in IACS Working Group:

None

.4 History of Decisions Made:

Lately some shipyards and manufacturers have received steel plates with pits and there has been discussion regarding how to interpret the extent and acceptance criteria for pitting. It was decided by the Survey Panel that the amendments to Rec.47

are necessary in order to improve the clarity of the document. And, there was a query from shipyards on the obscure definition of limit gap between plates for butt welding

.5 Other Resolutions Changes

None

.6 Dates:

Original Proposal: *07 April 2010 Made by: Survey Panel*

Panel Approval: *24 August 2010*

GPG Approval: *06 October 2010 (Ref: 10122_IGb)*

- **Rev.4 (Aug 2008)**

Revision based on Survey Panel Task 44. Ref: 8626_

See TB in Part B

- **Rev.3 (Nov 2006)**

Revision based on comments from SAJ. Ref: 4109a_

No TB document available

- **Rev.2 (Dec 2004)**

Revision proposed by WP/MW to GPG 52 (WP/MW Task 41). Ref: 4109_

No TB document available

- **Rev.1 (Aug 1999)**

Revision based on the revised SARQS (Table 8.7). Ref: 9139_

No TB document available

- **New (1996)**

No TB document available

Part B. Technical Background

List of Technical Background (TB) documents:

Annex 1 **TB for Rev.4 (Aug 2008)**

See separate TB document in Annex 1.

Annex 2 **TB for Rev.5 (Oct 2010)**

See separate TB document in Annex 2.

Annex 3 **TB for Rev.6 (May 2012)**

See separate TB document in Annex 3.

Annex 4. **TB for Rev.8 (Oct 2017)**

See separate TB document in Annex 4.

Note: *There are no separate Technical Background (TB) documents available for New (1996), Rev.1 (Aug 1999), Rev.2 (Dec 2004), Rev.3 (Nov 2006), Rev.7 (June 2013), Rev.9 (June 2021) and Rev.10 (Sep 2021).*

TECHNICAL BACKGROUND

IACS RECOMMENDATION NO.47 (REV.4, AUG 2008)

“Shipbuilding and Repair Quality Standard”

1. Scope and objective

PT was formed by Survey Panel (Task No.44) to develop a proposal to amend IACS Rec.47, SARQS (Shipbuilding and Repair Quality Standard) in order to align with major national shipbuilding standards.

2. Background

During IACS meeting with JSA (Japan Shipowners Association) and SAJ (Shipbuilders Association of Japan) in Tokyo, September 2005, SAJ made a presentation of areas of concern with IACS Rec.47. IACS agreed to submit the concerns to Survey Panel for action. IACS adopted Rev.3 of Rec.47 in November 2006, which was proposed by PT (Project Team) under the Survey Panel. The amendments in Rev.3 were based on the concern of SAJ that only the construction quality standards should be specified in SARQS and that some impractical recommendations should be revised. Upon the completion of Rev.3, IACS decided to develop a proposal to further amend IACS Rec.47 in order to align it with major national shipbuilding standards.

The Technical Background documents of the previous versions 1 and 2 do not exist.

3. Points of discussions

PT commenced the work through correspondence. After making considerable progress in the work, one meeting was held in Tokyo on 19th and 20th February, 2008 to finalize the amendments. PT members reviewed Rec.47 Rev.3 from the viewpoint of shipbuilding standards in their territories and their own experiences as well.

Initially PM gathered the information and comments from PT members on the results of the comparison of the Rec.47 with major national and certain shipyard standards practiced in China, Germany, India, Japan, Korea and Russia.

PT agreed to amend Rec.47 Rev.3 after the following discussion.

- Rec.47 should not be conflicted with major national shipbuilding standards to the extent possible
- Scope should be defined where Rec.47 applies
- Standard range and limit range should be listed
- Welding procedures should be qualified in accordance with IACS UR W28 or other recognized standard accepted by Classification Society

Upon a comprehensive review of national standards, PT found that there are notable variations among the major national standards in some technical parameters/approaches, maybe due to the differences in their respective technical basis, which would make a complete alignment not feasible. However, PT tried to accommodate the best practices of each of the considered major standards to the extent possible in order to finalize the Rec.47 Rev 4.

To improve the clarity of the recommendations, PT introduced necessary editorial changes.

Recognizing the importance of short bead welding in remedial work, PT introduced a new Table 9.14 according to JSQS.

Table 6.4 was amended to include the ovality of cylindrical structure according to FS (Production standard of the German Shipbuilding Industry).

In revision 2, in Table 9.4 and Table 9.5 (Typical Butt Weld Edge Preparation Remedial (Manual Welding and Semi-automatic welding)), the gap value, based on which the remedial standard is decided, was a function of the plate thickness. But in Revision 3 the gap value was modified to absolute value considering the comments from SAJ. During the PT meeting on 19 and 20 Feb 2008, it was agreed that the gap value is to be related to the thickness values, considering the comments from shipyards in Korea and elsewhere, to deal with thinner plates.

To avoid duplications and contradictions with other IACS technical requirements, some parts of the Rec.47 are modified.

4. Source and derivation of proposed standards

IACS Recommendation No.47 Rev.3 and Rev.4

5. Appendix

N.A.

Submitted by Project Team Manager

March 2008

Permanent Secretariat note:

PT's proposed amendments to Rec.47 were unanimously agreed by the Survey Panel and draft Rec.47 Rev.4 was submitted to GPG on 17 July 2008.

GPG approved Rec.47 Rev.4 on 4 August 2008 (ref. 8626_IGb).

Technical Background for Recommendation No.47 Rev.5, Oct 2010

1. Scope and objectives

To revise the Recommendation 47, Par.4.2.1 and 4.2.2 with the aim to eliminate uncertainties related to determining the imperfection surface area ratio and subsequently the acceptance criteria for minor imperfections which do not need to be repaired. And, to clarify the meaning of gap between edges of plates for Butt welding.

2. Engineering background for technical basis and rationale

While preparing a reply to the query from Daewoo Shipbuilding & Marine Engineering Co. Ltd. it was noticed that different societies have different interpretation of the acceptance criteria for minor imperfections without remedies. It was felt that including the definition of influenced area would improve the clarity of Recommendation 47 in this respect.

3. Source/derivation of the proposed IACS Resolution

The definition of the influenced area was adopted from European Standard EN 10163-1.

4. Summary of Changes intended for the revised Resolution:

New text defining the influenced area was added to Par.4.2.2.

A clear description on welding the gap with Butt weld plate was added to Table 9.5

5. Points of discussions or possible discussions

None

6. Attachments if any

None

Technical Background for Recommendation No.47 Rev.6, May 2012

1. Scope and objectives

Review of Recommendation 47 with reference to SSC-443 and in light of experience gained so far, update the Recommendation or identify needs to develop a set of requirements for the use of doubling plates for ships in operation, by Survey Panel.

2. Engineering background for technical basis and rationale

Technical discussion on the use of doublers aboard ship with reference to SSC-443 led to review and improvement of the current guidance in the Recommendation 47 relating to doublers.

3. Source/derivation of the proposed IACS Resolution

SSC-443 by the Ship Structure Committee (U.S.A.)

4. Summary of Changes intended for the revised Resolution:

Para 6.6 (Termination of straps) of Rec. 47 has been renamed and revised with following wordings:

6.6 Application of Doubling Straps

In certain instances, doubling straps are used as a means to strengthen and reinforce primary structure. Where this has been agreed and approved, particular attention should be paid to:

- the end termination points of the straps, so that toe support is such that no isolated hard point occurs.
- In the case of application of symmetrical or asymmetrical-ended straps, the corners at the end of the tapering should be properly rounded.
- any butts between lengths of doubling straps, so that there is adequate separation of the butt weld from the primary structure below during welding, and so that a high quality root run under controlled circumstances is completed prior to completing the remainder of the weld. Ultrasonic testing should be carried out on completion to verify full penetration.

Moreover, the corners are to be rounded for the symmetrical arrangement shown in Fig.6.6.

Also, references and titles of Rec 20, UR W13 and UR W14 were updated to current document titles.

5. Points of discussions or possible discussions

None

6. Attachments if any

None

Technical Background document for Recommendation No. 47 (Rev.8 Oct 2017)

1. Scope and objectives

To revise table 4.2 of Part B of IACS Recommendation No.47 to have consistent requirements against current industry standards.

2. Engineering background for technical basis and rationale

Table 4.2 of Part B of IACS Recommendation No.47 refer to recognised standards for steel grades comparable to the normal and high strength hull structural steels grades given in Classification Society rules. Some of standard references have been revised, and, the nomenclature of some steel grade becomes obsolete.

Table 4.2 of Part B of IACS Recommendation No.47 needs to be revised accordingly.

3. Source/derivation of the proposed IACS Resolution

Reference is made to IACS Recommendation 47 Part B (Rev.7).

4. Summary of Changes intended for the revised Resolution:

Table 4.2 of Part B of IACS Recommendation No.47 has been revised to align with current industry standards.

5. Points of discussions or possible discussions

The steel grades properties defined in industry standards ISO 4950-2, EN 10025:1990, EN 10025 series, JIS G 3106, GB 712-2011, were compared with steel grade properties specified in Classification Society 'Rules. The requirements were discussed and agreed with general consensus of the group.

6. Attachments if any

Nil.

Recommendation No. 48 “Recommendations on Loading Instruments”

Summary

Based on FUA 10 of GPG85, review of IACS Resolutions and Recommendations referring to industry standards was made. The review resulted in the necessary update of a reference in IACS Rec. 48.

Part A. Revision History

Version no.	Approval date	Implementation date when applicable
Rev.1 (June 2020)	3 June 2020	-
New (1997)	1997	-

• Rev.1 (June 2020)

1 Origin of Change:

- Other (*GPG85 FUA 10 Resolutions and Recommendations which refer to industry standards*)

2 Main Reason for Change:

The main technical reason for the change is to update the reference to the ISO Standard in section 3.1 and align the reference with the IACS principles on how such references should be made.

3 List of non-IACS Member classification societies contributing through the TC Forum and/or participating in IACS Working Group:

None

4 History of Decisions Made:

Proposal was provided by the Hull Panel chair, panel members provided their comments and agreed to the proposal.

5 Other Resolutions Changes:

None

6 Any hinderance to MASS, including any other new technologies:

None

7 Dates:

Original Proposal: 12 February 2020 Made by: Hull Panel Chair
Panel Approval: 11 May 2020 (Ref: 19000_PHb)
GPG Approval: 3 June 2020 (Ref: 19000_IGk)

- **New (1997)**

No history files or TB document available.

Part B. Technical Background

List of Technical Background (TB) documents for Rec 48:

Note: *There are no separate Technical Background (TB) documents available for Rec 48 New (1997) and Rev.1 (June 2020)*

Recommendation No. 52 “Power Supply to Radio Equipment required by SOLAS Chapter IV, and Electrical/Electronic Navigation Equipment required by SOLAS regulation V/19”

Summary

In Rev.2 of this Recommendation, the way to refer to instruments other than those specified by IACS was unified.

Part A. Revision History

Version no.	Approval date	Implementation date when applicable
Rev.2 (Feb 2021)	12 February 2021	-
Rev.1 (Sep 2005)	September 2005	-
New (May 1998)	May 1998	-

- **Rev.2 (Feb 2021)**

1 Origin of Change:

- Other (Periodical review to ascertain that the Recommendation is suitable for the latest developments in technology)

2 Main Reason for Change:

There was a need to ascertain that this Recommendation is suitable for the latest developments in technology.

To take this opportunity, references to IMO instruments have been specified in the following format based upon confirmation of amendments up to the latest one:

regulation/paragraph x.x.x of SOLAS Chapter X/MARPOL Annex X/the XXX Code, as amended by IMO resolutions up to MSC.xx(xx)/MEPC.xx(xx)

3 List of non-IACS Member classification societies contributing or participating in IACS Working Group:

None

4 History of Decisions Made:

None

5 Other Resolutions Changes:

None

6 Any hinderance to MASS, including any other new technologies:

None

7 Dates:

Original Proposal: 28 October 2019 (Ref: PM18939_IMd)
Panel Approval: 9 November 2020 (Ref: PM20906_IMf)
GPG Approval: 12 February 2021 (Ref: 20206cIGb)

- **Rev.1 (Sep 2005)**

No history file or TB document available.

- **New (May 1998)**

No history file or TB document available.

Part B. Technical Background

List of Technical Background (TB) documents for Recommendation No. 52:

Annex 1. **TB for Rev.2 (Feb 2021)**

See separate TB document in Annex 1.



Note:

1) *There are no separate Technical Background (TB) documents for Rec.52 New (Sep 2005) and Rev.1 (May 1998).*

Technical Background (TB) document for Rec 52 (Rev.2 Feb 2021)

1. Scope and objectives

Periodical review to ascertain that the Resolution is suitable for the latest developments in technology.

2. Engineering background for technical basis and rationale

Format for references to IMO instruments (where the number of amendments is large)

Format:

regulation/paragraph x.x.x of SOLAS Chapter X/MARPOL Annex X/the XXX Code, as amended by IMO resolutions up to MSC.xx(xx)/MEPC.xx(xx)

3. Source/derivation of the proposed IACS Resolution

None

4. Summary of Changes intended for the revised Resolution:

Technical validity of the contents of Recommendation No. 52 (Rev.1) was confirmed, taking into account the following:

- COMSAR Circ.32 (Aug. 2004) 7.1 Main Source & 7.2 Emergency source & 7.3 Reserve source of energy
- IEC 61174 (2015) : ECDIS : See 4.15

(232/A16.1) It shall be possible to operate ECDIS and all equipment necessary for its normal functioning when supplied by an emergency source of electrical power in accordance with the appropriate requirements of regulation II/1 of the 1974 SOLAS convention, as amended.

(232/A16.2) Changing from one source of power supply to another, or any interruption of the supply for a period of up to 45 s, shall not require the equipment to be manually re-initialized.

The equipment is not required to remain operational during this interruption of the power supply.

- IEC 61996-1 (2014) : VDR 4.5.2 (power source) & 4.5.3 (Dedicated reserve power Source)
- IEC 62616 : BNWAS

The BNWAS should be powered from the ship's Main power supply (as required by IEC 62616 [5.3]).

The BNWAS should also be powered from the ship's Emergency power supply (as required by SOLAS Part D-Reg. 43,[2.4.2] for Cargo Ships and Part D-Reg. 42,[2.3.2] for Passenger Ships).

The malfunction indication, and all elements of the Emergency Call facility (if provided), should be powered from a battery maintained supply, with enough capacity for supplying autonomy for at least 6hs. (IEC 62616 [7.4.20]).

5. Points of discussions or possible discussions

None

6. Attachments if any

None

Recommendation No. 53

“Periodic Survey and Testing of Foam Concentrates, CO2 and Halon Containers”

Summary

Changes made in Revision 1 of Recommendation 53 aligns the provisions with those in MSC.1/Circ.1318/Rev.1 on “Revised guidelines for the maintenance and inspections of fixed carbon dioxide fire-extinguishing systems”. Further, editorial changes were made keeping in view the recommendatory nature of the document and to update the references made from the document.

Part A. Revision History

Version no.	Approval date	Implementation date when applicable
Rev.1 (Oct 2023)	26 October 2023	-
New (1998)	1998	-

• Rev.1 (Oct 2023)

Changes made in Revision 1 contains amendments to Rec. 53 aligns the provisions with those in MSC.1/Circ.1318/Rev.1, updated references, and editorial updates (see Part B for details).

1 Origin of Change:

- Other: Maintenance review of IACS Resolutions

2 Main Reason for Change:

MSC 103 (May 2021) approved a revision 1 of MSC.1/Circ.1318 for a uniform application of the hydrostatic test regime for CO2 cylinders. MSC 107 (June 2023) agreed to revise MSC.1/Circ.1318/Rev.1 to further clarify the testing and inspection provisions for CO2 cylinders, based on paper MSC 107/17/22 by UK and IACS (ref. PS21003w).

Rec.53 is to a large extent overtaken by the test provisions in MSC.1/Circ.1318, however it contains provisions for low pressure CO2 bulk storage containers that are not covered by MSC.1/Circ.1317/Rev.1 and can therefore not be made obsolete at this point.

3 List of non-IACS Member classification societies contributing or participating in IACS Working Group:

N/A

4 History of Decisions Made:

Recommendation 53 on "Periodic Survey and Testing of Foam Concentrates, CO2 and Halon Containers" were originally the responsibility of the Machinery Panel. In July 2023, the Safety Panel assumed the responsibility for Rec. 53 due to its involvement with the revision of MSC.1/Circ.1318 (ref. 20206jIGb).

5 Other Resolutions Changes:

N/A

6 Any hinderance to MASS, including any other new technologies:

None.

7 Dates:

Original Proposal:	22 September 2023	(Ref: PS23033_ISe)
Panel Approval:	09 October 2023	(Ref: PS23033_ISf)
GPG Approval:	26 October 2023	(Ref: 20206jIGd)

• New (1998)

No history file or TB document available.

Part B. Technical Background

List of Technical Background (TB) documents for Recommendation No. 53:

Annex 1. **TB for Rev.1 (Oct 2023)**

See separate TB document in Annex 1.



Note:

1) *There are no separate Technical Background (TB) documents for Rec.53 New (1998).*

Technical Background (TB) document for Rec 53 (Rev.1 Oct 2023)

1. Scope and objectives

Maintenance review of IACS Resolutions.

2. Engineering background for technical basis and rationale

Removal of provisions that are not in accordance with those in MSC.1/Circ.1318/Rev.1, updating of references and editorial updates.

3. Source/derivation of the proposed IACS Resolution

Updating to reflect recent developments at the IMO, i.e., MSC.1/Circ.1318/Rev.1.

4. Summary of Changes intended for the revised Resolution:

- Paragraph 53.1.1.3: Provision for testing of high-pressure CO₂ containers replaced by a reference to MSC.1/Circ.1318/Rev.1.
- Paragraph 53.1.5: Footnote added, noting that the use of halon in general is prohibited.
- Paragraph 53.2: Updated IMO circular reference.
- Mandatory language replaced by non-mandatory language.
- The format updated to the current IACS template for Recommendations.
- Minor editorials.

5. Points of discussions or possible discussions

None.

6. Attachments if any

None.

Recommendation No.55

GENERAL DRY CARGO SHIPS - Guidelines for Surveys, Assessment and Repair of Hull Structure

Part A. Revision History

Version no.	Approval date	Implementation date when applicable
Rev.1 (June 2016)	17 June 2016	-
New (March 1999)	30 March 1999	-

• Rev 1 (June 2016)

.1 Origin of Change:

- Other (Periodical review of IACS resolutions)

.2 Main Reason for Change:

As outcome of the periodical review of the IACS recommendation 55.

.3 List of non-IACS Member classification societies contributing through the TC Forum and/or participating in IACS Working Group:

None

.4 History of Decisions Made:

Survey Panel discussed the revision of the Recommendation 55 by correspondence under Panel Task PSU15024. Several proposals of updating have been analysed and processed by the Members during the 22nd Survey Panel meeting. The proposals were mostly addressing:

- editorial comments,
- modification of some sketches of proposed repairs, for generic part of the ship, so that they are aligned to those contained in the other IACS Recommendations relevant to guidelines for surveys, assessment and repair of hull structure of other types of ships
- modification of some sketches of proposed repairs dedicated for the dry cargo ships
- updating of some photographs detailing the typical damages with new one which add more clarity.
- The removal of the reference to the Early Warning Scheme (paragraph 3.5) due to the fact that the recommendation is intended not only for IACS Members but also for ship's superintendent and other personnel not working in a Class Society.
- The addition of a new paragraph relevant to the "Voyage repairs and maintenance".

Panel Members agreed the modifications to be applied at the 22nd meeting and finalized the revision 1 by correspondence.

No TB has been expected.

.5 Other Resolutions Changes:

None

.6 Dates:

Panel Approval: 7 March 2016 (Ref: PSU15035)

GPG Approval: 17 June 2016 (Ref: 16060_IGd)

- **New (Mar 1999)**

No records available.

Part B. Technical Background

List of Technical Background (TB) documents for Rec.55:



Note: *There are no Technical Background (TB) documents available for New (Mar 1999) and Rev.1 (June 2016).*

Recommendation No.57

“Maintenance and inspection of electrical equipment on the ship”

Part A. Revision History

Version no.	Approval date	Implementation date when applicable
Rev.1 (Mar 2016)	9 March 2016	-
New (May 1999)	No record	-

• Rev.1 (Mar 2016)

.1 Origin for Change:

- Other (*Periodical review of IACS resolutions*)

.2 Main Reason for Change:

During the periodical review of the IACS recommendation 57 two members proposed to update maintenance schedule for electrical equipment.

.3 List of non-IACS Member Classification Societies contributing through the TC Forum and/or participating in IACS Working Group:

None

.4 History of Decisions Made:

Survey Panel discussed the two proposals under PSU15035 and during the 22nd Survey Panel meeting agreed to:

- line 7 of Table 1 by inserting the provisions requiring the examination of the computer equipment, where fitted, in accordance with the PAT testing (Portable Appliance Testing).
- insert the maintenance and inspection provisions for cooling system integrated within a switchboard enclosure to table 1.

It is also worth to note that Panel Members discussed by correspondence and agreed by the majority of Members the following two items:

- a) to modify/update the reference standards related to the provision for qualification and training personnel appointed for the maintenance and inspection, so that also the technicians in charge of the verification of medium voltage systems, dynamic positioning systems (for example) and other new electrical systems are being covered.
- b) to insert the requirement that the records for qualification and training of the personnel described in a) is made available on board.

Item b) was not agreed by GPG.

All the modifications agreed have been applied in the revision 1 of the recommendation.

No TB has been developed.

.5 Other Resolutions Changes

None

.6 Dates:

Panel Approval: 9 January 2016 (Ref: PSU15035)

GPG Approval: 9 March 2016 (Ref: 16004_IGc)

- **New (May 1999)**

No records available

Part B. Technical Background

List of Technical Background (TB) documents for Rec.57:



Note: *There are no Technical Background (TB) documents available for New (May 1999) and Rev.1 (Mar 2016).*

Recommendation No.58 “Fire Protection of Machinery Spaces”

Summary

This Recommendation provides a Guidance for fire protection of Machinery Spaces.

Part A. Revision History

Version no.	Approval date	Implementation date when applicable
Rev.2 (Feb 2021)	04 February 2021	-
Corr.1 (Jan 2004)	January 2004	-
Rev.1 (July 2003)	July 2003	-
New (June 1999)	June 2003	-

- **Rev.2 (Feb 2021)**

1 Origin of Change:

Based on IACS Requirement (Periodic review of IACS Resolution by Safety Panel)

2 Main Reason for Change:

Similar guidelines for measures to prevent fires in engine-rooms and cargo pump-rooms was approved as MSC.1/Circ.1321 on 11 June 2009 by the Maritime Safety Committee (MSC) in IMO. So, a new Note was added to make reference both documents together.

3 List of non-IACS Member classification societies contributing or participating in IACS Working Group:

None

4 History of Decisions Made:

Based on periodic review of IACS Resolution by Safety Panel, this document rather outdated. The Safety Panel agreed to update this recommendation.

5 Other Resolutions Changes:

None

6 Any hinderance to MASS, including any other new technologies:

Not applicable.

7 Dates:

Original Proposal: 11 December 2020 (Made by: Safety Panel)
Panel Approval: 18 January 2021 (Ref: PS19002mISb)
GPG Approval: 04 February 2021 (Ref: 19001gIGb)

- **Rev.1 Corr.1 (Jan 2004)**

No records available.

- **Rev.1 (July 2003)**

No records available.

- **New (June 1999)**

No records available.

Part B. Technical Background

List of Technical Background (TB) documents:



Note: There are no separate Technical Background (TB) documents for New (1999), Rev.1 (2003), Corr.1(2004) and Rev.2 (Feb 2021)

Recommendation No.60 “Intact stability of tankers during liquid transfer operations”

Summary

This document provides recommendations for tankers which are not subject to MARPOL Annex I Regulation 27 regarding intact stability during liquid transfer operation. The Corr.1 updates footnote 2 to refer to the 2008 IS Code rather than UI LL61 which is proposed for deletion.

Part A. Revision History

Version no.	Approval date	Implementation date when applicable
Corr.1 (Nov 2022)	08 November 2022	-
Rev.1 (Mar 2021)	26 March 2021	-
New (May 2001)	May 2001	-

• Corr.1 (Nov 2022)

1 Origin of Change:

- Other (*Proposed deletion of UI LL61*)

2 Main Reason for Change:

UI LL61 is referenced in footnote 2 of Rec.60. UI LL61 is proposed for deletion as its contents are contained in the 2008 IS Code.

Footnote 2 has therefore been updated to refer to the 2008 IS Code.

3 List of non-IACS Member classification societies contributing or participating in IACS Working Group:

None

4 History of Decisions Made:

Safety Panel agreed the amendment by correspondence.

5 Other Resolutions Changes:

None

6 Any hinderance to MASS, including any other new technologies:

None

7 Dates:

Original Proposal : 01 September 2022 (Made by Safety Panel)
Panel Approval : 21 October 2022 (Ref: PS19002wISe)
GPG Approval : 08 November 2022 (Ref: 19001xIGb)

• Rev.1 (Mar 2021)

1 Origin of Change:

Based on IACS Requirement (*Periodic review of IACS Resolution by Safety Panel*)

2 Main Reason for Change:

Resolution A.749(18) was revised, resulting the adoption of 2008 IS Code (Resolution MSC.267(85)) which is mandatory under 1974 SOLAS and 1988 Load Line Protocol. In addition, MARPOL Annex I was completely revised by Resolution MEPC.117(52).

3 List of non-IACS Member classification societies contributing or participating in IACS Working Group:

None

4 History of Decisions Made:

As a part of the maintenance of IACS Resolutions which have not been updated for the last ten years, Safety Panel agreed to revise Recommendation No.60 in order to revise the reference to Resolution A.749(18) to the 2008 IS Code and update the reference to MARPOL Annex I.

5 Other Resolutions Changes:

None

6 Any hinderance to MASS, including any other new technologies:

None

7 Dates:

Original Proposal: February 2021 (Made by: Safety Panel)
Panel Approval: 10 March 2021 (Ref: 19001mPSa)
GPG Approval: 26 March 2021 (Ref: 19001mIGb)

• New (May 2001)

No records available

Part B. Technical Background

List of Technical Background (TB) documents for Rec 60:

Note: *There are no separate Technical Background (TB) documents for New (May 2001), Rev.1 (Mar 2021) and Corr.1 (Nov 2022).*

Recommendation No. 61 “Recommended Maximum Allowable Rudder Pintle Clearance”

Summary

Deletion of no more useful recommendation.

Part A. Revision History

Version no.	Approval date	Implementation date when applicable
Del (Apr 2020)	18 April 2020	-
New (Jan 2000)	(No detail)	-

- **Del (Apr 2020)**

.1 Origin for Change:

- Other (Review of IACS instruments which have not been updated for the last ten years)

.2 Main Reason for Change:

For addressing GPG 85 FUA 9, Survey Panel reviewed the relevant Resolutions and Recommendations which have not been updated for the last ten years, and agreed to delete Recommendation 61 because the Recommendation is considered invalid due to the fact that the maximum allowable rudder pintle clearance should be provided by OEM.

.3 List of non-IACS Member classification societies contributing through the TC Forum and/or participating in IACS Working Group:

None

.4 History of Decisions Made:

Survey Panel reviewed and agreed to delete Recommendation 61 because the Recommendation is considered invalid due to the fact that the Maximum Allowable Rudder Pintle Clearance should be provided by OEM.

5 Other Resolutions Changes:

None

6 Any hindrance to MASS, including any other new technologies:

None

7 Dates:

Original Proposal: 29 November 2018 (Requested by GPG Vice-Chair)
Panel Approval: 06 March 2020 (Ref: PSU19016)
GPG Approval: 18 April 2020 (Ref: 19001_Ige)

- **New (Jan 2000)**

(No details)

Part B. Technical Background

List of Technical Background (TB) documents for UI SC 182:

There is no separate technical background document available for Rec.61 New (Jan 2000) and Del (Apr 2020).



Recommendation No. 67

“Test and Installation of Busbar Trunking Systems”

Part A. Revision History

Version no.	Approval date	Implementation date when applicable
Rev.1 (June 2018)	12 June 2018	-
New (June 2000)	June 2000	-

- **Rev.1 (June 2018)**

.1 Origin for Change:

- Suggested by IACS member

.2 Main Reasons for Change:

The checking and updating of international standards that referenced by IACS resolutions has been carried out by Machinery panel. As a result, it is found that there is a need to update the international standards that referred in the IACS resolution Rec 67.

.3 List of non-IACS Member Classification Societies contributing through the TC Forum and/or participating in IACS Working Group:

None

.4 History of Decisions Made:

Replace IEC 60332-1 with IEC 60332-1-1 & IEC 60332-1-2;
 Replace IEC 60439-1 with IEC 61439-1 & IEC 60439-2 with IEC 61439-6.

.5 Other Resolutions Changes

None

.6 Dates:

Original Proposal: 22 May 2015, made by Machinery Panel
 Panel Approval: 11 May 2018 (Ref: PM5901)
 GPG Approval: 12 June 2018 (Ref: 18082_IGc)

- **New (June 2000)**

No records available.

Part B. Technical Background

List of Technical Background (TB) documents for Rec 67:

Annex 1. **TB for Rev.1 (June 2018)**

See separate TB document in Annex 1.



Note: *There is no Technical Background (TB) document available for New (June 2000).*

Technical Background (TB) document for Rec 67 (Rev.1 June 2018)

1. Scope and objectives

To make amendment to Rec 67 in order to update the international standards that referenced in this IACS resolutions.

2. Engineering background for technical basis and rationale

None.

3. Source / derivation of the proposed IACS Resolution

The task of checking and updating of international standards that referenced by IACS resolutions carries out every five years. From 21st Meeting of IACS MP, the working scope extended from IEC standards referenced to all MP related international standards.

4. Summary of Changes intended for the revised Resolution

None

5. Points of discussions or possible discussions

After discussion, the edition year for the standards referenced in the original version has been removed, the panel agrees that while it would be good to reference a specific year (or version), nevertheless this may result in additional work to review and amend the IACS documents every time an update to an external standard is published. It is therefore preferred that in general the reference does not include the year/version such that the IACS documents always refer to the latest standard (unless there are specific reasons to refer to a particular version).

6. Attachments if any

None

Rec 68 "Guidelines for non-destructive testing of hull and machinery steel forgings"

Summary

The content of Rec 68 has been fully reworked and revised with following changes:

- Updated standards reference (external and IACS) to current version.
- Editorial changes to clarify the scope of Rec.
- Addition of clarifying text on the use of angle beam probes and of explanatory text when using RT.
- Update on UT and DAC requirements and acceptance criteria.
- application of this Rec. extended to the testing of austenitic stainless steel and ferritic-austenitic (duplex) stainless steel forgings.

Part A. Revision History

Version no.	Approval date	Implementation date when applicable
Rev.1 (Apr 2021)	7 April 2021	-
New (June 2000)	June 2000	-

• Rev.1 (Apr 2021)

1 Origin of Change:

- ✓ Suggestion by IACS member

2 Main Reason for Change:

IACS Rec.68 to be updated where necessary and relevant, with considerations of the following: international standards; any relevant IACS documents; review and clarification of technical testing parameters; review of acceptance standards

3 List of non-IACS Member classification societies contributing or participating in IACS Working Group:

No contribution by non-IACS Member classification societies.

4 History of Decisions Made:

- Proposal to revise IACS Rec 68 was confirmed by EG/MW Chairman on 16 April 2019. This was an action that derived from GPG, to revise EG/MW related UR's and Rec's, originally developed under a separate task.
- Task was assigned on 29 May 2019.

- Form A was submitted by task lead in October 2019.
- Five drafts have been discussed by the group.
- Discussions took place regarding personnel qualifications, and relevance and applicability to UR W35.

Consensus was made to adopt some of the content of UR W35, and a general agreement that UR W35 is not fully applicable in its entirety to Rec 68, due to the decision made within UR W35 discussions that NDT service suppliers are not applicable to manufacturers. However, some of the general principles were adopted for personnel requirements.

- Discussions and agreement took place regarding extending this Recommendation to the testing of austenitic stainless steel and ferritic-austenitic (duplex) stainless steel forgings.
- EG/MW members agreed on the revisions made for technical revisions to (mainly) UT requirements – specifically, introduction of DAC acceptance criteria (with introduction of new Tables, specifying DAC acceptance criteria [equivalent to DGS present limits] when UT testing).
- EG/MW members agreed that there is no current need to generally change the acceptance criteria limits and considers the acceptance criteria for hull and machinery steel forgings as sufficiently robust compared to other industry standards. Furthermore, no members expressed any particular industry feedback that these requirements need to be changed.
- Final draft submitted 04 March 2021 to EG/MW and advised by EG/MW Chairman that this should be the final draft.

5 Other Resolutions Changes:

None.

6 Any hinderance to MASS, including any other new technologies:

None.

7 Dates:

Original Proposal: 13 April 2019 (Made by GPG)
 EG M&W Approval (for task 1909): 16 April 2019
 EG M&W Approval (for 5th and final draft of this revision task): 20 March 2021
 GPG Approval: 7 April 2021 (Ref: 19255_IGb)

- **New (June 2000)**

No records available

Part B. Technical Background

List of Technical Background (TB) documents:

Annex 1. **TB for Rev.1 (Apr 2021)**

See separate TB document in Annex 1.



Note: *There are no separate Technical Background (TB) documents for New (June 2000).*

Technical Background (TB) document for Rec 68 (Rev.1 Apr 2021)

1. Scope and objectives

The scope of Rec 68 is to provide guidelines for the non-destructive examination/non-destructive testing of hull and machinery steel forgings. The recommendation details general requirements (including NDE/NDT personnel qualifications), and makes provision for both surface and volumetric testing, using common industry methods. The recommendation also provides acceptance criteria for defect evaluation when applied to hull and machinery steel forgings, for the selected testing methods.

The objectives of this revision were to perform a general review of Rec.68 to assess the following aspects, and recommend any necessary changes:

- Its relevance to current industry standards, including the specified date/version of that standard
- Its relevance to other IACS Resolutions, since 2000.
- Where any new standards are specified in the revision, the corresponding versions will also be included.
- Edit, review, update where necessary, by preparing a new (revised) draft
- Review the current acceptance criteria, and revise if considered necessary
- Review the NDE/NDT methodologies, and revise if considered necessary.

2. Engineering background for technical basis and rationale

This recommendation was originally published in 2000, with no further revisions until this revision task was implemented. IACS GPG and EG/MW agreed that a review was required to assess the technical relevance compared with industry standards and IACS Resolutions.

The summary of main changes is described in section 4 of this Annex, and the following technical points were considered in the preparation of this revision:

- A comprehensive literature review was carried out to attempt to align (and reference, if appropriate), any relevant external standards for acceptance purposes, e.g. EN 10228 (parts 1-4), ASTM A745.
- The review also consisted of a review of historic and current procedural reviews involving UT and MT/PT on forged components.
- The above review revealed that a direct comparison was not easily obtained, nor clear enough for inclusion.
- Furthermore, IACS members networking with internal and external relevant stakeholder feedback suggested that there isn't currently any fundamental issue with current acceptance standards within REC.68 (in terms of defect sizes).

- In addition, service experience suggests that the current robust level of NDE/NDT acceptance criteria is not a factor contributing to any failure of components.
- An in-depth comparison was made (conducted by experienced ISO 9712 UT level 3 specialists) into the comparison of, and potential introduction of DAC sensitivity acceptance criteria. DAC sensitivity acceptance criteria does not feature in the original version of Rec.68 and has now been introduced into Rev 1.
- Industry (and comprehensive procedure reviews) indicates that DAC method is a popular testing regime, and simplifies the practical testing
- Furthermore, DGS is often not used in some countries and /or organisations, so these considerations formed part of the review.
- In addition, some modern equipment – particularly UT probes – may not be entirely suitable for application of DGS method.
- The review also consisted of considerations and references to other IACS documents, and relevance to product types currently within Rec. 68 (e.g. UR's M68 and M72)
- Introduction (from a comprehensive review) on formulation of new content to ascertain equivalent DAC acceptance criteria
- Introduction/extension of this Recommendation scope for the inclusion of austenitic stainless steel and ferritic-austenitic (duplex) stainless steel forgings.
- Revising the requirements for repair/defect rectification, as EG/MW opinion is that this is an NDT standard, and not a repair standard
- A decision was made *not to change the existing acceptance criteria for defect length/size*, as there doesn't appear to be an explicit need (or feedback) to do so.
- A decision was made *not to change or revise* the Annex figures (other than minor edits/ numbering revisions)
- Introduction of other test methods (eddy current testing) for defect confirmation and/or detection of unauthorised weld repairs (note – no acceptance criteria is assigned to this method – it is mentioned for qualitative purposes only)

3. Source/derivation of the proposed IACS Resolution

Existing Classification Societies Rules as well as the following international standards have been considered:

- ASTM A745 / A745M – 20: Standard Practice for Ultrasonic Examination of Austenitic Steel Forgings
- EN 10228-1:2016: Non-Destructive Testing of Steel Forgings. Magnetic Particle Inspection.
- EN 10228-2:2016: Non-Destructive Testing of Steel Forgings. Penetrant Testing.

- EN 10228-3:2016: Non-Destructive Testing of Steel Forgings. Ultrasonic testing of ferritic or martensitic steel forgings.
- EN 10228-4:2016: Non-Destructive Testing of Steel Forgings. Ultrasonic testing of austenitic and austenitic-ferritic stainless steel forgings.

4. Summary of Changes intended for the revised Resolution:

The content of Rec 68 has been fully reworked and revised with major changes summarised hereafter:

- Update language and terminology (where applicable) to reflect general industry nomenclature, and alignment with other revised IACS documents
- Update or introduce new standards references (external and IACS) to current version, and to reflect new or revised UR's published since Rev. 1
- Deletions/additions, and general formatting for clarity
- Insertion of statement for dealing with products not explicitly covered by Rec. 68
- Introduction/extension of scope for the inclusion of austenitic stainless steel and ferritic-austenitic (duplex) stainless steel forgings.
- Indication definitions generally aligned to new revisions in UR W24 +W27, and Rec 69
- Revised (mainly deleted and improved) text regarding repair of forgings/rectification of defects. In summary, removed repair procedure text which is not intended to form part of the recommendations.
- Some additional requirements to reporting criteria
- Briefly introduce advanced UT methods (as referenced in UR W34)
- Proposed clarity on the use of angle beam probes
- Clarification of UT DGS criteria when applied to zone 1 in crankshafts (Table 3)
- Update on general UT requirements, and details regarding the setting up of, and using DAC sensitivity
- Introduction of UT acceptance criteria, to account for DAC sensitivity method, with a direct comparison to existing DGS method (and further guidance on the use of other Flat Bottom Holes [FBH] for setting up equivalent DAC on different size FBH's).
- Introduction of other test methods (eddy current testing) for defect confirmation and/or detection of unauthorised weld repairs (note – no acceptance criteria is assigned to this method – it is mentioned for qualitative purposes only)

5. Points of discussions or possible discussions

- Personnel qualifications, and relevance and applicability to UR W35:
Consensus was made to adopt some of the content of UR W35, and a general agreement that UR W35 is not fully applicable in its entirety to Rec 68, due to the decision made within UR W35 discussions that NDT service suppliers are not applicable to manufacturers. However, some of the general principles were adopted for personnel requirements.
- Agreement regarding the additional scope and (and subsequent new references for UT standards) for testing austenitic and duplex forgings.
- Agreement that no further changes or standards need to be introduced regarding surface testing of austenitic and duplex forgings.
- Agreed on the revisions and technical rationale for UT requirements – specifically, introduction of DAC acceptance criteria.
- EG/MW members agreed that there is no current need to change the acceptance criteria limits (defect sizes) and considers the acceptance criteria for hull and machinery forgings as suitably robust compared to other industry standards. Furthermore, no members expressed any particular industry feedback that these requirements need to be changed

6. Attachments if any

No attachments, however, the following numerical formula was used as a basis in the construction of DAC equivalent acceptance for UT (extract from ASTM E2375 – 16):

Based on the formula $40 \log_{10}$ (reference FBH dia / acceptance FBH dia. from ASTM E 2375-16 Standard practice for ultrasonic examination of wrought products).

$$40 \log_{10} \left[\frac{\text{reference FBH diameter}}{\text{acceptance FBH diameter}} \right] = \text{dB}$$

Therefore:

$$40 \log_{10} (6 / 12) = 12 \text{ dB} \ \& \ 40 \log_{10} (6 / 15) = 16 \text{ dB}$$

Rec 69 “Guidelines for non-destructive testing of marine steel castings”

Summary

The content of Rec 69 has been fully reworked and revised with following changes:

- Updated to standards reference (external and IACS) to current version.
- Editorial changes to clarify the scope of Rec.
- Addition of clarifying text on the use of angle beam probes and of explanatory text when using RT.
- Update on UT and DAC requirements and acceptance criteria.

Part A. Revision History

Version no.	Approval date	Implementation date when applicable
Rev.2 (Oct 2020)	20 October 2020	-
Rev.1 (May 2004)	May 2004	-
New (June 2000)	June 2000	-

• Rev.2 (Oct 2020)

1 Origin of Change:

- ✓ Suggestion by IACS member

2 Main Reason for Change:

IACS Rec.69 to be updated where necessary and relevant, with considerations of the following: international standards; any relevant IACS documents; review and clarification of technical testing parameters; review of acceptance standards

3 List of non-IACS Member classification societies contributing or participating in IACS Working Group:

No contribution by non-IACS Member classification societies.

4 History of Decisions Made:

- Proposal to revise IACS Rec 69 was confirmed by EG/MW Chairman on 16 April 2019. This was an action that derived from GPG, to revise EG/MW related UR's and Rec's, originally developed under a separate task.

- Task was assigned on 29 May 2019.
- Form A was submitted by task lead in October 2019.
- Three drafts have been discussed by the group.
- Discussions took place regarding personnel qualifications, and relevance and applicability to UR W35.

Consensus was made to adopt some of the requirements of UR W35, and general agreement that UR W35 is not fully applicable in its entirety to Rec 69, due to the decision made within UR W35 discussions that NDT service suppliers are not applicable to manufacturers. However, some of the general principles were adopted for personnel requirements.

- Discussions and agreement took place regarding additional references to RT standards for volumetric testing, where UT may not be applicable.
- EG/MW members agreed on the revisions made for technical revisions to (mainly) UT requirements – specifically, introduction of DAC acceptance criteria (with introduction of figure 1 as an illustration of DAC curve when UT testing).
- EG/MW members agreed that there is no current requirement to change the acceptance criteria limits and considers the acceptance criteria for marine castings as sufficiently robust compared to other industry standards.

Furthermore, no members expressed any particular industry feedback that these requirements need to be changed.

- Final draft (draft 3) submitted 08 July 2020 to EG/MW and advised by EG/MW Chairman that this should be the final draft.

5 Other Resolutions Changes:

None

6 Any hinderance to MASS, including any other new technologies:

None

7 Dates:

Original Proposal:	13 April 2019 (Made by GPG)
EG M&W Approval:	2 October 2020 (Ref: 19256_EMWb)
GPG Approval:	20 October 2020 (Ref: 19256_IGb)

- **Rev.1 (May 2004)**

No records available

- **New (June 2000)**

No records available

Part B. Technical Background

List of Technical Background (TB) documents:

Annex 1. **TB for Rev.2 (Oct 2020)**

See separate TB document in Annex 1.



Note: *There are no separate Technical Background (TB) documents for Recommendation No.69 New (June 2000) and Rev.1 (May 2004).*

Technical Background (TB) document for Rec 69 (Rev.2 Oct 2020)

1. Scope and objectives

The scope of Rec 69 is to provide guidelines for the non-destructive examination/non-destructive testing of marine steel castings. The recommendation details general requirements (including NDE/NDT personnel qualifications), and makes provision for both surface and volumetric testing, using common industry methods. The recommendation also provides acceptance criteria for defect evaluation when applied to marine castings, for the selected testing methods.

The objectives of this revision were to perform a general review of Rec.69 to assess the following aspects, and recommend any necessary changes:

- Its relevance to current industry standards, including the specified date/version of that standard
- Its relevance to other IACS Resolutions, since 2004 (and relevant version)
- Where any new standards are specified in the revision, the corresponding versions will also be included.
- Edit, review, update where necessary, by preparing a new (revised) draft
- Review the current acceptance criteria, and revise if considered necessary
- Review the NDE/NDT methodologies, and revise if considered necessary.

2. Engineering background for technical basis and rationale

This recommendation was originally published in 2000 and revised in 2004. No review or further revisions have been carried out until this present revision (rev.2), therefore, GPG and EG/MW agreed that a review was required to assess the technical relevance compared with industry standards and IACS Resolutions.

The summary of main changes is described in section 4 of this Annex, and the following technical points were considered in the preparation of this revision:

- A comprehensive literature review was carried out to attempt to align (and reference, if appropriate), any relevant external standards for acceptance purposes, e.g. ISO 4992 (parts 1 & 2).
- The review also consisted of a review of historic and current procedural reviews involving UT and MT on cast components.
- The above review revealed that a direct comparison was not easily obtained, nor clear enough for inclusion.
- Furthermore, IACS members networking with internal and external relevant stakeholder feedback suggested that there isn't currently any fundamental issue with current acceptance standards within REC.69 (in terms of sizing).
- In addition, service experience suggests that the current robust level of NDE/NDT acceptance criteria is not a factor contributing to any failure of components.
- An in-depth comparison was made (conducted by experienced ISO 9712 UT level 3 specialists) into the comparison of, and potential introduction of DAC sensitivity acceptance criteria. Whilst DAC is mentioned in Rec 69, it was felt that further clarification and guidance was needed.
- Industry (and comprehensive procedure reviews) indicates that DAC method is a popular testing regime, and simplifies the practical testing

- Furthermore, DGS is often not used in some countries and /or organisations, so these considerations formed part of the review.
- In addition, some modern equipment – particularly UT probes – may not be entirely suitable for application of DGS method.
- The review also consisted of considerations and references to other IACS documents, and relevance to product types currently within Rec. 69
- Introduction (from a comprehensive review) on formulation of new content to ascertain equivalent DAC acceptance criteria
- Revising the requirements for repair/defect rectification, as LR opinion is that this is an NDT standard, and not a repair standard
- A decision was made *Not to change or revise the existing acceptance criteria*, as there doesn't appear to be an explicit need (or feedback) to do so.
- A decision was made *Not to change or revise the Annex figures* (other than numbering updates)

3. Source/derivation of the proposed IACS Resolution

Existing Classification Societies Rules as well as the following international standards have been considered:

- ASTM E2375 – 16: Standard Practice for Ultrasonic Testing of Wrought Products (for derivation of DAC reflector comparison formula),
- ASTM E446 – 15: Standard Reference Radiographs for Steel Castings Up to 2 in. (50.8 mm) in Thickness,
- ASTM E186 - 15(2019) e1: Standard Reference Radiographs for Heavy-Walled (2 to 412 in. (50.8 to 114 mm)) Steel Castings,
- ASTM E280 - 15(2019) e1: Standard Reference Radiographs for Heavy-Walled (412 to 12 in. (114 to 305 mm)) Steel Castings,
- ISO 4993:2015: Steel and iron castings-Radiographic testing
- ISO 4992-2:2006: Steel castings —Ultrasonic examination —Part 2: Steel castings for highly stressed components
- ISO 4992-1:2006: Steel castings —Ultrasonic examination —Part 1: Steel castings for general purposes
- ISO 4986:2010: Steel castings —Magnetic Particle Inspection
- EN 1370 Founding – examination of surface condition

4. Summary of Changes intended for the revised Resolution:

The content of Rec 69 has been fully reworked and revised with major changes summarised hereafter:

- Update language and terminology (where applicable) to reflect general industry nomenclature, and alignment with other revised IACS documents

- Update or introduce new standards references (external and IACS) to current version, and to reflect new or revised UR's published since Rev. 1
- Deletions/additions, and general formatting for clarity
- Insertion of new paragraphs for dealing with products not explicitly covered by Rec. 69
- Indication definitions generally aligned to new revisions in UR W24 +W27, and Rec 68
- Revised (mainly deleted and improved) text regarding repair of castings/rectification of defects. In summary, removed repair procedure text which is not intended to form part of the recommendations.
- Some additional requirements to reporting criteria
- Briefly introduce advanced UT methods (as referenced in UR W34)
- Proposed clarity on the use of angle beam probes
- Clarification of DAC method (equivalent to existing DGS criteria)
- Update on general UT requirements, and details regarding the setting up of, and using DAC sensitivity
- Clarification of UT acceptance criteria, to account for DAC sensitivity method, with a direct comparison to existing DGS method (and further guidance on the use of other Flat Bottom Holes [FBH] for setting up equivalent DAC on different size FBH's).
- Introduction of a new figure (fig 1) to clarify DAC method sensitivity
- Addition of explanatory text when using RT, and suggested reference standards in a guidance format

5. Points of discussions or possible discussions

- Personnel qualifications, and relevance and applicability to UR W35: Consensus was made to adopt some of the requirements of UR W35, and general agreement that UR W35 is not fully applicable in its entirety to Rec 69, due to the decision made within UR W35 discussions that NDT service suppliers are not applicable to manufacturers. However, some of the general principles were adopted for personnel requirements.
- Agreement regarding additional references to RT standards for volumetric testing, where UT may not be applicable.
- Agreed on the revisions made for technical revisions to (mainly) UT requirements – specifically, introduction of DAC acceptance criteria (with introduction of figure 1 as an illustration of DAC curve when UT testing).
- EG/MW members agreed that there is no current requirement to change the acceptance criteria limits and considers the acceptance criteria for marine castings as suitably robust compared to other industry standards. Furthermore, no members expressed any particular industry feedback that these requirements need to be changed

6. Attachments if any

No attachments, however, the following numerical formula was used as a basis in the construction of DAC equivalent acceptance for UT (extract from ASTM E2375 – 16):

Based on the formula $40 \log_{10}$ (reference FBH dia. / acceptance FBH dia. from ASTM E 2375-16 Standard practice for ultrasonic examination of wrought products).

$$40 \log_{10} \left[\frac{\text{reference FBH diameter}}{\text{acceptance FBH diameter}} \right] = \text{dB}$$

Therefore:

$$40 \log_{10} (6 / 12) = 12 \text{ dB} \ \& \ 40 \log_{10} (6 / 15) = 16 \text{ dB}$$

Rec 70 “Guidelines on welding procedure qualification tests of aluminium alloys for hull construction and marine structures”

Summary

Review and update industry standards format according to GPG instructions

Part A. Revision History

Version no.	Approval date	Implementation date when applicable
Rev.2 (Sep 2021)	21 September 2021	-
Rev.1 (Nov 2006)	Nov 2006	-
New (June 2000)	June 2000	-

• Rev.2 (Sep 2021)

1 Origin of Change:

- Suggestion by IACS member

2 Main Reason for Change:

To update industry standards format according to GPG instructions given in GPG Vice-chair message 19000_IRC.

3 List of non-IACS Member classification societies contributing through the TC Forum and/or participating in IACS Working Group:

None.

4 History of Decisions Made:

Original proposal was made according to GPG Vice-chair message 19000_IRC. Proposal to revise the IACS URs and RECs only to refer to a dated version of the industry standard as per GPG instructions was made at IACS EG/MW meeting in September 2019. Three drafts have been discussed by the group.

5 Other Resolutions Changes:

None.

6 Any hinderance to MASS, including any other new technologies:

None.

7 Dates:

Original Proposal	: April 2019	(Made by GPG)
EG M&W Approval	: July 2021	
GPG Approval	: 21 September 2021	(Ref: 19000_IGq)

- **Rev.1 (Nov 2006)**

No records available.

- **New (June 2000)**

No records available.

Part B. Technical Background

List of Technical Background (TB) documents for Rec 70:

Annex 1. **TB for Rev.1 (Nov 2006)**

See separate TB document in Annex 1.

Annex 2. **TB for Rev.2 (Sep 2021)**

See separate TB document in Annex 2.

Note: *There is no Technical Background (TB) document available for New (June 2000).*

**TECHNICAL BACKGROUND DOCUMENT
IACS RECOMMENDATION No.70 (REV.1, NOV 2006)**

1. Scope and objective

To develop a UR or Recommendation for welding procedure qualification tests for aluminium alloys 5383 and 5059.

2. Background

Rec.70 was produced in 2000. In 2004 new important industrial accepted specifications of aluminium alloy 5383 and 5059 were added to UR W25. These should be incorporated into the Recommendation and at the same time it may be upgraded to a UR for welding procedure qualification tests for the alloys based upon elaborate considerations.

3. Points of discussions or possible discussions

- Hull Panel PT2 unanimously agreed that the revised document should be retained as a recommendation.
- It was therefore submitted as a revision to the existing Recommendation No.70 to the Hull Panel on 3 March 2006.
- Accordingly Hull Panel reviewed it and comments made by GL were sent back to the PT2 on 12 April 2006.
- With regard to GL's comments, having received replies from PT2 on 25 July in addition to comments made by ABS and CCS, the Hull Panel further reviewed them and finally agreed unanimously to the final draft revision to Recommendation No. 70 at the 5th Hull Panel meeting held on 16-18 October 2006.

4. Source/derivation of proposed requirements

- IACS Recommendation No. 70 (Rev.2)

5. Appendix

N.A.

Submitted by Hull Panel Chairman
27 October 2006

Permanent Secretariat Note (December 2006):

- Rec.70, Rev.2 was approved by GPG and Council on 15 November 2006 (6187_IGb), with the request that PermSec update the language to be a non-mandatory style, i.e. replacing terms such "are to be" and "shall" with "should", etc., to avoid confusing the public domain about the non-mandatory nature of the Recommendation.
- Following approval GL proposed some additional editorial amendments to improve the readability of the document and emphasize the relation of Rec.70 to UR W28 (GLb). However after bilateral communication between GPG Chair and Hull Panel Chair it was proposed to deal with these amendments at the next appropriate revision of Rec.70. This proposal received no objections from GPG members.

Technical Background (TB) document for Rec 70 Rev.2 Sep 2021

1. Scope and objectives

Review and update industry standards format according to GPG instructions.

2. Engineering background for technical basis and rationale

None.

3. Source/derivation of the proposed IACS Resolution

ISO 4063:2009
ISO 10042:2018
ISO 14175:2008

4. Summary of Changes intended for the revised Resolution:

Industry standards format has been updated according to GPG instructions.

5. Points of discussions or possible discussions

None.

6. Attachments if any

None.

Recommendation No.71

“Guide for the development of shipboard technical manuals”

Part A. Revision History

Version no.	Approval date	Implementation date when applicable
Corr.1 (Mar 2014)	04 March 2014	-
New (Sept 2000)	26 September 2000	-

- **Corr.1 (Mar 2014)**

1 Origin for Develop:

- Suggestion by IACS Permsec

.2 Main Reasons for Develop:

To correct the reference to an ISO standard in Para 7.1.1.

.3 List of non-IACS Member classification societies contributing through the TC Forum and/or participating in IACS Working Group:

None.

.4 History of Decisions Made:

A typographical error was found in Para 7.1.1 of recommendation 71. ISO 8879 was wrongly referenced as ISO 8779. The correction has been made by Permsec.

.5 Other Resolutions Changes

None.

.6 Dates:

Original Proposal: 18 February 2014 by IACS Permsec
GPG Approval: 04 March 2014 (Ref: 14026_IGb)

- **New (Sep 2000)**

Developed by WP/HE in September 2000 (Ref: 0085aIGb)

Part B. Technical Background

Note: No Technical Background (TB) document has been prepared for Recommendation No.71 (New, Sep 2000) and Corr.1 (Mar 2014).

Recommendation No.72 "Confined Space Safe Practice"

Summary

This Recommendation is revised aligning with IACS PR 37, with the main texts being re-structured as Part One, and the guidelines annexed to this Recommendation being restructured as Part Two.

Part A. Revision History

Version no.	Approval date	Implementation date when applicable
Rev.4 (Jan 2025)	08 January 2025	-
Rev.3 (Dec 2018)	01 December 2018	-
Corr.1 (Sep 2017)	18 September 2017	-
Rev.2 (Apr 2007)	April 2007	-
Rev.1 (Oct 2003)	October 2003	-
New (2000)	2000	-

• Rev.4 (Jan 2025)

1 Origin for Change:

- Based on IACS Requirement (PR 37)
- Based on Other Standard (IMO Res. A 1050(27))

2 Main Reason for Change:

The changes made in PR37 and incorporation of hazards and safety practices associated with alternate fuels and NORMs (Naturally Occurring Radioactive Materials) / LSA (Low Specific Activity) scales.

3 List of non-IACS Member Classification Societies contributing through the TC Forum and/or participating in IACS Working Group:

None

4 History of Decisions Made

The EG/SOS has revised the Rec.72 by correspondence within the EG members by considering Members own internal procedures/rules, experience/expertise of Members, relevant requirements/guidelines of IMO, ISO/IEC standards, other international standards and best practices within the industry.

All the amendments/changes made by the EG/SOS are agreed by all members unanimously.

5 Other Resolutions Changes

None

6 Dates:

Original Proposal : 31 July 2023 (Ref: 23015_ESd)
Panel Approval : 02 December 2024 (Ref: 23015_ESf)
GPG Approval : 08 January 2025 (Ref: 23015_IGi)

• Rev.3 (Dec 2018)

.1 Origin for Change:

- Based on IACS Requirement (PR 37)
- Based on Other Standard (ISO 19891-1:2017(en))

.2 Main Reason for Change:

The finalization of Rev.3 of Recommendation 72 was put on hold by 13138_IGe, awaiting finalization of ISO standard on multi-gas meters. As ISO has finalized and published ISO 19891-1:2017(en), the work on Rev.3 of Recommendation 72 can be continued.

.3 List of non-IACS Member Classification Societies contributing through the TC Forum and/or participating in IACS Working Group:

None

.4 History of Decisions Made

The drafted Rev.3 of Recommendation 72 being put on hold by 13138_IGe was developed by the former EG/SoS in 2013, with no TB attached.

Survey Panel reviewed the history discussions on Rec. 72 since 2013, and finalized the Rev.3 of Rec. 72 together with a TB.

Please refer to the TB document in Annex 2 of Part B.

.5 Other Resolutions Changes

Para 2.8 of Rev.2 of PR 37 was entered with "F+T", in accordance with the table given in Chapter 19 of IGC Code.

.6 Dates:

Original Proposal: By Persmec
Panel Approval: 15 November 2018 (Ref: 17119_PYd).
GPG Approval: 01 December 2018 (Ref: 17119_IGh)

- **Corr.1 (Sep 2017)**

.1 Origin for Change:

- Other (Editorial correction identified by Persmec)

.2 Main Reason for Change:

Corrections needed to CO & CO₂ limit values were identified in the table by Whitherby's Publication group and Persmec.

.3 List of non-IACS Member Classification Societies contributing through the TC Forum and/or participating in IACS Working Group:

None

.4 History of Decisions Made

Table was corrected as the following by Survey panel and GPG:

Gas	Limit 8 Hour work shift [ppm]	Limit 15 min working [ppm]
Carbon Dioxide (CO ₂)	5 5000	30 10000
Carbon Monoxide (CO)	25 20	50

.5 Other Resolutions Changes

None

.6 Dates:

Original Proposal: 27 July 2017 by Persmec
Panel Approval: 30 August 2017 (Ref: 17119_PYa).
GPG Approval: 18 September 2017 (Ref: 17119_IGb)

- **Rev.2 (Apr 2007)**

Refer TB document in Annex1 of Part B.

- **Rev.1 (Oct 2003)**

No history files or TB document available.

- **New (2000)**

No history files or TB document available.

Part B. Technical Background

List of Technical Background (TB) documents for Rec.72:

Annex 1. **TB for Rev.2 (Apr 2007)**

See separate TB document in Annex 1.

Annex 2. **TB for Rev. 3 (Dec 2018)**

See separate TB document in Annex 2.



Note: *There are no separate Technical Background (TB) documents for New (2000), Rev.1 (Oct 2003), Corr.1 (Sep 2017) and Rev.4(Jan 2025).*

Technical Background

IACS Recommendation 72, Rev. 2 (April 2007)

Survey Panel Task 46 – Safe Entry into Tanker Double Hull Spaces

1. Objective

Update as necessary IACS recommendation 72 to include Safe Entry Practices for Surveyors into Double Hull Spaces when adjacent cargo tanks are empty but inerted or the cargo tanks are loaded

2. Background

ABS Panel member raised this issue to the Survey Panel at the Spring 2006 Panel meeting due to no current guidelines being available.

3. Methodology of Work

Survey Panel members through Project Team and correspondence

4. Discussion

Survey Panel Project Team members at the spring 2007 meeting discussed the amendments to Recommendation 72 based on the initial draft proposed by DNV PT member.

All survey panel members agreed to the amendments which consisted of two parts, i.e., Recommendation 72 and Annex to the Recommendation.

Submitted by Survey Panel Chairman
27 March 2007

Permanent Secretariat note (August 2007):

- Amendments agreed by GPG 14 April 2007 (6079_IGh).
- Owing to the extent of the amendments, including a change to the document layout, Rev.2 of Rec.72 has been treated as a complete revision and as such no underlined document is available.

Technical Background (TB) document for Rec 72 (Rev.3 Dec 2018)

1. Scope and objectives

This Recommendation provides a guideline to assist Classification Societies in developing Confined Space Entry (CSE) procedures or technical instructions for the Surveyors, when conducting confined space entry activities, according to a common reference standard of good practice.

The Guideline is structured in two parts. Part one includes general information with definitions and requirements for confined spaces safe entry, and Part two includes detailed guidelines on recognizing the hazards associated with confined spaces and making a safe survey preparation and entry.

A Checklist for Entry into Confined Space is also annexed to this recommendation.

2. Engineering background for technical basis and rationale

The marine industry continues to have fatalities where confined spaces are entered that are not safe for human occupancy. Good practices for confined space safe entry are widely known including that those who enter and work in confined spaces are competent to do so, that the space has been confirmed containing a safe atmosphere, that a safe system of work is adopted, that suitable personal protective equipment is used, and that the confined space safety entry policy and procedure are established. IACS developed this guideline based on the good practices of its members and the industries.

3. Source/derivation of the proposed IACS Resolution

- IACS member expertise
- IACS member practices for confined space entry
- IACS PR 37 "Procedural Requirement for Confined Space Safe Entry"
- IACS Recommendation No. 39 - Safe use of Rafts or Boats for Survey
- ISGOTT International Safety Guide for Oil Tankers and Terminals, fifth edition.
- Tanker Safety Guide Chemicals, third edition
- Tanker Safety Guide Liquid Gas, second edition 1995
- OCIMF - Health, Safety and Environment at New-building and Repair Shipyards and During Factory acceptance testing (01 July 2003)

4. Summary of Changes intended for the revised Resolution

- 4.1 A preamble "Introduction" was developed to introduce the scope and objectives of the Recommendation.
- 4.2 This Recommendation was re-structured in two parts. Part one included the main texts of the previous version of the recommendation with the previous Sections 3 to 8 being re-structured as Sections 3 and 4, and Part two included the guideline in the previous annex to the Recommendation.
- 4.3 Definitions of the following terms were entered in Part One for aligning with IACS PR 37: Confined Space Entry, Attendant, Adjacent Space, Toxic Product, Surveyor and Permit to Enter / Permit to Work.

- 4.4 The item c of the previous Section 4.1 (new Section 3.3.1 of Part One) was removed.
- 4.5 Item H of Section 3.3.1 of Part One was newly added, including a recommendation about EEBDs to be placed at the entry of a confined space for emergency rescue.
- 4.6 Item I of Section 3.3.1 of Part One was inserted with wordings that the surveyor's personal gas measurements during the survey shall not substitute the measurements taken by the Owner/or Owner Representative.
- 4.7 The safety limit values of oxygen in Sections 3.3.1 and 4.0 of Part One, and Section 3.2 of Part Two, and the Checklist annexed to this Recommendation were both revised as "20.6% to 22%" by volume, aligning with IACS PR 37.
- 4.8 In the table of Sub-Section "Testing for toxic atmospheres" (under new Section 4.0, previous Section 6), the following rows in the previous version were removed: Carbon Dioxide (CO₂), Nitrogen Dioxide (NO₂), Nitrogen Monoxide (NO) and Sulphur Dioxide (SO₂).
- 4.9 Section 4.2 (Personal Protection Equipment) of Part One was revised as follows:
- 4.9.1 The item for Multi-gas meter was added with a footnote, referring to Referring to ISO 19891-1:2017(en) "Ships and marine technology — Specifications for gas detectors intended for use on board ships — Part 1: Portable gas detectors for atmosphere testing of enclosed spaces".
- 4.9.2 For aligning with IACS PR 37, the previous item "Lighting" was replaced with a new item "A flashlight".
- 4.9.3 Item "Respiratory protection (e.g. dust mask)" was newly added.
- 4.9.4 Item 4.2.1 was newly added for aligning with paragraph 3.3.2 of IACS PR 37.
- 4.10 Section 2.1.1 of Part Two, in the table "Health effects from lack of oxygen", the row relevant to "22%" of the previous version was removed.
- 4.11 Section 8.2 of Part Two, the wording "In general a pocket size backup light" was replaced with "A flashlight".
- 4.12 The annexed Checklist for Entry into Confined Spaces was updated with several items being amended and several items being inserted.
- 4.13 The picture in the cover page was replaced with several pictures, showing the surveyors taking appropriate PPEs.

5. Points of discussions or possible discussions

- 5.1 When discussing the contents of the first paragraph of Section 1.8 Toxic Product of Part One, Survey Panel realized that the toxic gases assigned with suffixes "F+T" in column "f" of table given in Chapter 19 of IGC Code should be

also additionally included, and agreed to insert 'or "F+T"' into this paragraph;

- 5.2 In view of that a new ISO standard 19891-1 regarding the multi-gas meter was already developed in 2017, Survey Panel Members agreed to add a footnote to the "multi-gas meter" of paragraph 4.2 of Part Two, referring to this ISO Standard;
- 5.3 When discussing the Personal Protection Equipment (PPE) of Section 4.2 of Part One, Survey Panel concurred with the view that "Lighting" is not a PPE and should be replaced with "A flashlight", and made the revisions as listed in the above items 4.9.2 and 4.11. Furthermore, as proposed by one member, Survey Panel agreed to add a PPE "Respiratory protection (e.g. dust mask)" in this Section, which might be used when entering the confined spaces of a ship in a shipyard or a dockyard;
- 5.4 For aligning with IACS PR 37 regarding the safe atmospheric oxygen limits (20.6% to 22% by volume) for safe entry to a confined Space, which were derived from the guidance in Section 2.1.1 "Oxygen-deficient atmosphere" of the guidelines annexed to Revision 2 of Rec 72 (in the table "Health effects from lack of oxygen", the normal oxygen level for safe entry was 20.8% "+" or "-" 0.2%, and the enriched atmospheric oxygen level was 22%), the safety limit values of oxygen throughout this Recommendation were revised as "20.6% to 22%" by volume (please refer to the above item 4.7);
- 5.5 According to the practices of IACS members of CSE, the atmospheric limits of CO₂, NO₂, NO and SO₂ in the confined space are normally not required when the Oxygen and the other hazardous gases are measured, and the revisions as in the above item 4.8 were duly effected;
- 5.6 Please also refer to the TB of Rev.0 of PR 37, for the other revisions aligning with PR 37.

6. Attachments if any

None

Recommendation No. 73

“Type approval procedure for cable trays/protective casings made of plastics materials”

Summary

In Rev.3 of this Recommendation, the resistivity test requirement in section 4.1 has been revisited, referring to the latest publication of IEC standard and contacting IEC TC in charge.

Part A. Revision History

Version no.	Approval date	Implementation date when applicable
Rev.3 (Dec 2023)	21 December 2023	-
Rev.2 (Jan 2023)	23 January 2023	-
Corr.1 (Oct 2021)	20 October 2021	-
Rev.1 (Dec 2020)	11 December 2020	-
New (June 2002)	June 2002	-

• Rev.3 (Dec. 2023)

1 Origin of Change:

- Suggestion by IACS member

2 Main Reason for Change:

A member expressed concerns over the adequacy of surface resistivity value which revised in Rec. No.73 Rev.2. Thereafter the Panel agreed to conclude after consulting with IEC TC in charge.

3 List of non-IACS Member classification societies contributing or participating in IACS Working Group:

None

4 History of Decisions Made:

The Panel confirmed to retain the surface resistivity value.

5 Other Resolutions Changes:

None

6 Any hinderance to MASS, including any other new technologies:

None

7 Dates:

Original Proposal:	16 October 2023	(Ref: PM23400_IMg)
Panel Approval:	06 December 2023	(Ref: PM23400_IMj)
GPG Approval:	21 December 2023	(Ref: 23228_IGb)

• Rev.2 (Jan 2023)

1 Origin of Change:

Suggestion by IACS member

2 Main Reason for Change:

The surface sensitivity in section 4 has been revised from 10^6 to 10^8 Ohm [Ω] based on IEC standard 61537:2006.

3 List of non-IACS Member classification societies contributing or participating in IACS Working Group:

None

4 History of Decisions Made:

None

5 Other Resolutions Changes:

None

6 Any hinderance to MASS, including any other new technologies:

None

7 Dates:

Original Proposal :	16 February 2022	(Ref: PM20906gIMg)
Panel Approval :	26 December 2022	(Ref: PM20906gIMI)
GPG Approval :	23 January 2023	(Ref: 22206_IGb)

• Corr.1 (Oct 2021)

1 Origin of Change:

Suggestion by IACS member

2 Main Reason for Change:

There was a need to correct editorial errors which were identified after approval of Rev.1 of this Recommendation.

3 List of non-IACS Member classification societies contributing or participating in IACS Working Group:

None

4 History of Decisions Made:

None

5 Other Resolutions Changes:

None

6 Any hinderance to MASS, including any other new technologies:

None

7 Dates:

Original Proposal : 23 March 2021 (Ref: PM20906gIMa)
Panel Approval : 29 July 2021 (Ref: PM20906gIMd)
GPG Approval : 20 October 2021 (Ref: 20206_IGm)

• Rev.1 (Dec 2020)

1 Origin of Change:

- Other (Periodical review to reflect the latest IMO Resolutions and update to comply with the required format when industry standards are referred to)

2 Main Reason for Change:

There was a need to update this REC to reflect the latest IMO Resolutions related to the FTP Code and to comply with the following format when industry standards are referred to:

[Standard Designation], [version/revision, if applicable], [year of publication] (examples: API Spec 2F, 6th Edition, 1997; ISO 4624, 2002), where [version/revision, if applicable] and/or [year of publication] are decided by IACS and are not necessarily to be the current/latest version.

To take this opportunity, references to IMO instruments have been specified in the following format based upon confirmation of amendments up to the latest one:

regulation/paragraph x.x.x of SOLAS/MARPOL/the XXX Code, as amended by resolutions MSC/MEPC.xx(xx), (...) and MSC/MEPC.xx(xx)

3 List of non-IACS Member classification societies contributing or participating in IACS Working Group:

None

4 History of Decisions Made:

None

5 Other Resolutions Changes:

None

6 Any hinderance to MASS, including any other new technologies:

None

7 Dates:

Original Proposal	: 28 October 2019	(Ref: PM18939_IMd)
Panel Approval	: 09 November 2020	(Ref: PM20906_IMf)
GPG Approval	: 11 December 2020	(Ref: 20206_IGb)

• **New (June 2002)**

No history file or TB document available.

Part B. Technical Background

List of Technical Background (TB) documents for Rec 73:

Annex 1. **TB for Rev.1 (Dec 2020)**

See separate TB document in Annex 1.

Annex 2. **TB for Corr.1 (Oct 2021)**

See separate TB document in Annex 2.

Annex 3. **TB for Rev.2 (Jan 2023)**

See separate TB document in Annex 3.

Annex 4. **TB for Rev.3 (Dec 2023)**

See separate TB document in Annex 4.

Note: For Technical Background (TB) of Recommendation No.73 new (June 2002), refer to the TB file of UR E16. This TB for UR E16 was issued retrospectively in Feb 2007 following evaluation of Petrobras Brasil query on UR E16 and Rec.73 by Machinery Panel (ref. 6097_).

Technical Background (TB) document for Rec. No 73 (Rev.1 Dec 2020)

1. Scope and objectives

Recommendation No. 73 (Original version) does not reflect the latest IMO Resolutions related to the FTP Code or the agreed format for referencing the IEC Standard. Rev.1 has been developed to comply with the agreed format.

2. Engineering background for technical basis and rationale

A) Update to reflect latest IMO Resolutions

Amendments to the FTP Code as per IMO Resolutions MSC.307(88) and MSC.437(99) were reflected in Recommendation No. 73.

B) References to IMO instruments

Format:

regulation/paragraph x.x.x of SOLAS/MARPOL/the XXX Code, as amended by resolutions MSC/MEPC.xx(xx), (...) and MSC/MEPC.xx(xx)

C) Format for references to Industry standards

[Standard Designation], [version/revision, if applicable], [year of publication]
(examples: API Spec 2F, 6th Edition, 1997; ISO 4624, 2002), where [version/revision, if applicable] and/or [year of publication] are decided by IACS and are not necessarily to be the current/latest version.

3. Source/derivation of the proposed IACS Resolution

None

4. Summary of Changes intended for the revised Resolution:

Recommendation No. 73 has been updated to specify the revision/version of the IEC Publication and the FTP Code as follows:

IEC Publication	Replaced by
IEC 60068-2-75	IEC 60068-2-75:2014
IEC 60093	IEC 62631-3-1:2016 and IEC 62631-3-2:2015
IEC 61537	IEC 61537:2006
FTP Code	Replaced by
MSC.61(67), Part 2	Part 2 of 2010 FTP Code adopted by IMO Resolution MSC.307(88) as amended by IMO Resolution MSC.437(99)

5. Points of discussions or possible discussions

None

6. Attachments if any

None

Technical Background (TB) document for Rec. No 73 (Corr.1 Oct 2021)

1. Scope and objectives

There was a need to correct editorial errors which were identified after approval of Rev.1 of this Recommendation.

2. Engineering background for technical basis and rationale

The below editorial errors in Paragraph 4.1, including its Note, of this Recommendation have been identified:

1. *105 ohm* to be corrected as follows: *10⁵ ohm meter [Ω m]*;
2. *106 ohm* to be corrected as follows: *10⁶ ohm [Ω]*; and
3. *tray/pro-TECTIVE* to be corrected as follows *tray/protective*.

3. Source/derivation of the proposed IACS Resolution

None

4. Summary of Changes intended for the revised Resolution:

Refer to the above item 2.

5. Points of discussions or possible discussions

Review of this Recommendation to change *10⁶ ohm [Ω]* in Paragraph 4.1 to *10⁸ ohm [Ω]* will be carried out, taking into account IEC 61537.

6. Attachments if any

None

Technical Background document for Rec 73 (Rev.2 Jan 2023)

1. Scope and objectives

To upgrade the surface resistivity in Paragraph 4.1 from 10^6 ohm [Ω] to 10^8 ohm [Ω].

2. Engineering background for technical basis and rationale

The revision is based on IEC standard 61537:2006 "Cable management – Cable tray systems and cable ladder systems", which in part 11.2 reads:

11.2 Electrical non-conductivity

Cable tray system components and cable ladder system components declared according to 6.4.2 shall be deemed electrically nonconductive if having surface resistivity values of 100 M Ω or greater.*

Metal cable tray systems and metal cable ladder systems with a coating are considered as conductive.

Compliance is checked by the following tests for system components according to 6.1.2 or 6.1.3:.....

***6 Classification**

.....

6.4 According to electrical conductivity

6.4.1 Electrically conductive system component

6.4.2 Electrically non-conductive system component

Therefore, since the standard categorizes cable tray system components as non-conductive if the surface resistivity is 100 M Ω or greater and the Recommendation advises in 4.1 that the cable trays/protective casings when passing through a hazardous area should be electrically conductive, the wording in 4.1 of the Recommendation needed modification to read ...*the surface resistivity should be below ~~10^6~~ 10^8 ohm [Ω].*

3. Source/derivation of the proposed IACS Resolution

IEC standard 61537:2006 "Cable management – Cable tray systems and cable ladder systems"

4. Summary of Changes intended for the revised Resolution:

Refer to the above item 2.

5. Points of discussions or possible discussions

The following additional comment has been raised by a member:

*...there is a Note for resistance to earth under the second paragraph of 4.1.
And the Note describes the 10^6 ohm as a criterion for resistance to earth.
....the panel should be considered whether this criterion 10^6 ohm also is to be revised or not. And it may be helpful for PT PM47 to review this issue.*

Note: The resistance to earth from any point in these appliances should not exceed 10^6 ohm [Ω].

One member expressed the following disagreement: *....the "resistance to earth from any point in these appliances" depends on the installation, such as resistance in fixing points of the trays to the hull.does not consider this note to be suitable in a recommendation for type approval procedures and suggests that it is deleted.*

According to the qualified majority, the Note under the second paragraph of 4.1 has been retained.

6. Attachments if any

None

Technical Background document for Rec 73 (Rev.3 Dec 2023)

1. Scope and objectives

To revisit resistivity test requirement in paragraph 4.1 of the cable trays/protective casings of plastic materials.

2. Engineering background for technical basis and rationale

After a concern was raised on the adequacy of surface resistivity value which was increased from 10^6 to 10^8 Ohm [Ω] in Rev.2 of REC 73, the Panel investigated the issue referring to the latest edition of the reference standard and also contacting IEC TC in charge.

3. Source/derivation of the proposed IACS Resolution

IEC standard 61537:2023 "Cable management – Cable tray systems and cable ladder systems"

4. Summary of Changes intended for the revised Resolution:

The Panel confirmed to retain the surface resistance value which is aligned with IEC 61537:2023 and the response from IEC TC.

Taking the opportunity, the introductory part of paragraph 4.1 has been rephrased for better understanding and clarity.

Updating the IEC standard version to IEC 61537:2023 in Appendix 1.

5. Points of discussions or possible discussions

A member asked about the expression "from any point" in Note to paragraph 4.1.

The panel found the necessity to modify the expression "between any point and the ship's hull" based on the understanding that it is same requirement as what in clause 5.5 Static electricity of IEC 60092-502 and the one in paragraph 1 of UR E9.

However, Panel decide to delete the note in paragraph 4.1 as no agreement achieved by majority in the panel to update the phrase, as mentioned note found more related to ship installation rather than related to type approval of products in question.

6. Attachments if any

None

Recommendation No.74

“A Guide to Managing Maintenance in accordance with the requirements of the ISM Code”

Summary

Recommendation 74 gives guidance regarding managing maintenance in accordance with the requirements of ISM Code. Rev.2 of this publication is issued considering the new technologies on Condition Based Inspecting/Maintenance (CBM). Also CBM is included in the checklist of Principal Maintenance System Management Controls.

Part A. Revision History

Version no.	Approval date	Implementation date when applicable
Rev.2 (Aug 2018)	06 August 2018	-
Rev.1 (May 2008)	May 2008	-
New (April 2001)	April 2001	-

- **Rev.2 (Aug 2018)**

.1 Origin of Change:

- Suggested by IACS member

.2 Main Reason for Change:

To address the FUA 11 of C73, raised by the Council of the IACS in respect to the future work directions on the implications of new technology on Remote Monitoring/Diagnosis (RMD) and Condition Based Inspecting/Maintenance (CBM).

Survey Panel discussed the issue and agreed to establish a PT to provide suggestions for the possible revisions of the relevant IACS Resolutions and Recommendations (e.g. UR Z18, UR Z20, Rec.74) and the draft of new Recommendations/Guidelines which may help the concrete application of these technologies.

.3 List of non-IACS Member Classification Societies contributing through the TC Forum and/or participating in IACS Working Group:

None

.4 History of Decisions Made:

Survey panel discussed this issue under Panel task PSU16057 allocated by GPG on 21th October 2016. The subject deals with the review of the UR and Recommendation under Panel responsibility in order to determine whether a revision could need in order to consider the new technologies on Remote Monitoring/Diagnosis (RMD) and Condition Based Inspecting/Maintenance (CBM).

In this respect the Survey Panel discussed the topics and agreed that a PT dealing with the matters would be advisable in order to provide suggestions for the possible revisions of the relevant IACS Resolutions and Recommendations (e.g. UR Z18, UR Z20, Rec 74) and the draft of new Recommendations/Guidelines which may help the concrete application of these technologies.

PT PSU34/2017 was established, and made revisions mostly addressing the following:

- Modification of item ii) in Maintenance intervals under paragraph 2.
- Insert "measurements" into the paragraph of Inspection methods under paragraph 2.
- Insert "Condition monitoring reports, where applicable" into part A and part B of paragraph 3.
- Insert new item 19 of CBM into the checklist.

During the 26th Survey Panel meeting, panel members concurred with comments on PT's submission and proposed actions were taken by the PT. Survey Panel reviewed the drafts which was further amended and agreed by Survey Panel.

Finally, the qualified majority of the Panel Members agreed the draft text of the UR Z 27 and modifications to UR Z18, UR Z20 and Recommendation 74.

Refer to TB Document in Annex 2.

.5 Other Resolutions Changes

UR Z18, UR Z20

.6 Dates:

Original Proposal: 21 October 2016 assigned by GPG

Panel Approval: 24 July 2018 by Survey Panel (Ref: PSU16057)

GPG Approval: 06 August 2018 (Ref: 18076_IGg)

- **Rev.1 (May 2008)**

Refer TB Document in Annex 1.

- **New (April 2001)**

No records available.

Part B. Technical Background

List of Technical Background (TB) documents for Rec 74:

Annex 1. **TB for Rev.1 (May 2008)**

See separate TB document in Annex 1.



Annex 2. **TB for Rev.2 (Aug 2018)**

See separate TB document in Annex 1.



Note: *There is no Technical Background (TB) document available for New (April 2001).*

Technical Background (TB) document for Rec 74 (Rev.1 May 2008)

The ISM/ISPS Expert Group has made a number of changes to Recommendation 74. These changes do not alter the document substantially but are intended to emphasise the following two aspects of maintenance management that the Group felt had not been sufficiently addressed in the original version.

1. The need for companies to be concerned not only with the rectification of technical defects and hazardous situations but also with the identification and resolution of the underlying management systems failures that led to the problems in the first place.
2. The importance of a systematic approach to the assessment of risk when planning an effective maintenance management system.

At the same time, the opportunity was taken to clarify the wording of the introduction.

17th April 2008
Michael Molloy, LR

Øivind N. Bråten
Chairman EG-ISM/ISPS

Submitted by Statutory Panel Chairman: 04 May 2008

Permanent Secretariat note (June 2008):
Rec.74, Rev.1 approved by GPG 30 May 2008 (ref. 8582_IGc)

Technical Background (TB) document for Rec 74 (Rev.2 Aug 2018)

1. Scope and objectives

Upon the investigations of new technologies' implications on survey regime, IACS developed this unified requirement to the approved Condition Monitoring and Condition Based Maintenance schemes applying to the machinery components and systems where the condition monitoring results are used to influence the scope and/or frequency of Class survey, including the requirements of software, onboard working, documentation, personnel, approval and survey for applying the scheme, and survey/audit for maintenance of the scheme.

2. Engineering background for technical basis and rationale

As far as the PT members have been able to conclude, the CBM is a set of maintenance actions based on real-time or near-real time assessment of equipment condition which is obtained from embedded sensors and/or external tests & measurements taken by portable equipment. From a Classification Society's consideration, the RMD embraces similar principles of monitoring. Apart of CBM and RMD there exist various systems of monitoring based on acquisition and processing of information and data that indicate the state of a machine over time. With emerging technologies such as Radio Frequency IDentification (RFID), various sensors, Micro-Electro-Mechanical System (MEMS), wireless tele-communication, Supervisory Control and Data Acquisition (SCADA) and Product Embedded Information Devices (PEID) there are expected to be rapidly used in the world such systems for gathering and monitoring the status of components. Moreover, the CBM scheme in general can be treated as a method used to reduce the uncertainty of maintenance activities and embraces various condition monitoring/diagnosis technologies and techniques such as lubricant/fuel, wear particle, bearing temperature, infrared thermography and motor current signature analysis.

Having recognized that, the PT agreed the subsequent Guidelines shall not be limited only by CBM and RMD systems and decided to leave opportunity for implementation existing and forthcoming systems based on the principals of the condition monitoring/diagnosing intrinsic to the CBM.

3. Source/derivation of the proposed IACS Resolution

The PT reviewed the current IACS Resolutions and Recommendations and detected paragraphs potentially impacted.

4. Summary of Changes intended for the revised Resolution:

The PT prepared a draft of a new document UR Z27 covering Condition Monitoring and Condition Based Maintenance schemes where the condition monitoring results are used to influence the scope and/or frequency of Class survey. Besides, the PT proposed a draft of corrigenda to the UR Z18, UR Z20 and Recommendation 74.

5. Points of discussions or possible discussions

The task was triggered by GPG to review and set the future work directions on the implications of new technology on survey regime, in relation with other technologies, especially the Remote Monitoring/Diagnosis (RMD) and the Condition Based

Inspecting/Maintenance (CBM). A project team was agreed to be established, and the Form A and Form 1 were agreed by GPG on 24/03/2017.

PT manager submitted the PT outcomes to the Survey Panel meeting on 25/08/2017, and some comments were got from panel members before the 26th panel meeting.

During the 26th Survey Panel meeting, a Member introduced their comments and indicated that as a minimum requirement, the related UR shall include the minimum parameters to be checked in order to monitor the condition of the various machinery for which this type of maintenance is accepted; The panel agreed with the view of a Member that for ease of understanding and implementation, revisions should be made in UR Z20 only, to include the elements of the proposed new UR instead of having two separate URs.

The PT suggested:

- that elaborating on requirements would likely to limit UR's applicability for ensuing technologies, thus no changes are required.
- to steer a course of action had been embarked on during the team joint work and be committed to have a separate UR Z27 instead of merging the requirements with UR Z20.

Based on preceding discussion it was concluded that qualified majority of the Panel Members agreed with PT's opinion that a separate UR for CM/CBM as designed by PT was the appropriate course of action.

PT, after examination of the Panel's comments, prepared

- a new version of the draft UR addressing the comments and suggestions, and
- the technical justifications/explanations.

On October 2017 PT sent to the Panel the new version of the draft.

Finally, the qualified majority of the Panel Members agreed the draft text of the UR Z27 and modifications to UR Z18, UR Z20 and Recommendation 74.

6. Attachments if any

None

Rec 75 "Format for Electronic Exchange of Class and Statutory Data"

Summary

Corr.1 to Recommendation 75 (Revision 3) updates the name of an IACS member Society referred in Appendix. Condition of Class"

Part A. Revision History

Version no.	Approval date	Implementation date when applicable
Corr.1 (Oct 2020)	09 October 2020	-
Rev.3 (Jan 2020)	08 January 2020	-
Rev.2 (Dec 2016)	16 December 2016	-
Corr.1 (Feb 2016)	-	-
Rev.1 (Feb 2015)	10 February 2015	-
New (June 2001)	4 June 2001	-

• Corr.1 (Oct 2020)

.1 Origin for Change:

- Suggestion by IACS member

.2 Main Reasons for Develop:

To update the name of an IACS member Society from "Korean Register of Shipping" to "Korean Register".

.3 List of non-IACS Member Classification Societies contributing or participating in IACS Working Group:

None

.4 History of Decisions Made:

An IACS member requested to update its company name referred in Appendix of Recommendation 75 from "Korean Register of Shipping" to "Korean Register".

GPG endorsed to make a relevant corrigenda.

.5 Other Resolutions Changes

PR 16

. 6 Any hinderance to MASS, including any other new technologies:

None

.7 Dates:

Original Proposal: 22 September 2020 (made at GPG by a GPG Member)
EG Approval: -
GPG Approval: 9 October 2020 (Ref: 20156_IGb)

• Rev.3 (Jan 2020)

.1 Origin for Change:

- Suggestion by IACS member
- Based on IACS Requirement (*GPG policy decision to use the terminology "Condition of Class" (CoC)" and "Statutory Condition" instead of the terms "Recommendation" or "Recommendation / Condition of Class ; as per 17044bIGr)*)

.2 Main Reasons for Develop:

- Review the data model, to make it more conceptual to facilitate its mapping against any other data model of classification societies, make it more flexible to manage changes, enable easier addition of data, to facilitate the management of potential individual requests from flag states and / or other maritime stakeholders, facilitate the request for harmonization of data models from other maritime stakeholders
- Define a governance to manage potential changes (editorial board)
- Get rules or guidelines for the data exchange (direction, technical protocol) to avoid specific development for each Flag State
- This revision is to address the policy decision made by GPG using the common terminology 'Condition of Class'(CoC) instead of the terms 'Recommendation/ Condition of Class' based on the outcome of III 5.

.3 List of non-IACS Member Classification Societies contributing through the TC Forum and/or participating in IACS Working Group:

None.

.4 History of Decisions Made:

- Following suggestion of EG-Data members all issues has been duly discussed and incorporated.
- During the 29th panel meeting, the panel discussed about the comments of members, and concurred with the view to retain the present definitions of CoC

in the IACS resolutions with the wording 'Recommendation' to be removed. The panel also agreed to use the term 'Statutory Condition' for the 'recommendation' of the statutory certificates in IACS resolutions and RECs, and when discussing the proposal of a member to consider the harmonization of the terms of 'recommendation' and 'condition of class' in RO Code, the panel unanimously agreed to take no action on the IMO instruments, leaving the relevant actions to be decided by the relevant IMO bodies when IACS feeds back to IMO the IACS action on the harmonization of the two terms.

- Panel members concurred with the view that it is not necessary to develop a new procedure requirement, and agreed to set the implementation date of these IACS resolutions (other than RECs) as 1st July 2020.
- Before the implementation date of 1st July 2020 for using the common terminology 'Condition of Class' only, 'Recommendations' and 'Condition of Class' are to be read as being different terms used by Societies for the same thing, i.e. requirements to the effect that specific measures, repairs, surveys etc. are to be carried out within a specific time limit in order to retain Classification.

.5 Other Resolutions Changes

The following IACS resolutions and Recommendations (RECs) were agreed to be revised:

- Procedural Requirements: PR1A, PR1B, PR1C, PR1D, PR1 Annex, PR3, PR12, PR20, PR35 and the attachment of PR16;
- Unified Requirements: Z7, Z7.1, Z7.2, Z10.1, Z10.2, Z10.3, Z10.4, Z10.5, Z15 and Z20
- Unified Interpretations: GC13
-
- Recommendations: Rec.41, Rec.96, Rec.98

. 6 Any hinderance to MASS, including any other new technologies:

None.

.7 Dates:

Original Proposal : 15 July 2019 (made by EG-Data)
EG Approval: 30 September 2019
GPG Approval: 08 January 2020 (Ref: 18175_IGh)

• Rev.2 (Dec 2016)

1 Origin for Change:

- Suggestion by IACS member

.2 Main Reasons for Develop:

To further amend REC75 Rev.1 and bugfix of findings on first implementations.

.3 List of non-IACS Member Classification Societies contributing through the TC Forum and/or participating in IACS Working Group:

None.

.4 History of Decisions Made:

Following suggestion of the EG-Data members all issues has been duly discussed and incorporated.

.5 Other Resolutions Changes

None.

. 6 Any hinderance to MASS, including any other new technologies:

None.

.7 Dates:

Original Proposal: 07 April 2016 from GPG80 - FUA 10
EG Approval: 19 October 2016 (Ref: 16076_EDc)
GPG Approval: 16 December 2016 (Ref: 16076_IGg)

• Corr.1 (Feb 2016)

1 Origin for Change:

Suggestion from an IACS Member

.2 Main Reasons for Develop:

To correct DNV GL's details and codes.

.3 List of non-IACS Member classification societies contributing through the TC Forum and/or participating in IACS Working Group:

None.

.4 History of Decisions Made:

Following suggestion from DNV GL, Permsec reviewed Rec.75 and updated DNV GL's details and codes. The new revision has been confirmed by DNV GL before being circulated to GPG for information.

.5 Other Resolutions Changes

None.

. 6 Any hinderance to MASS, including any other new technologies:

None.

.7 Dates:

Original Proposal: Feb 2016, made by DNV GL
Circulate to GPG for information: 17 February 2016 (Ref: 16041_IAa)

• Rev.1 (Feb 2015) (Complete Revision)

1 Origin for Change:

Suggestion by IACS GPG (GPG 71 (FUA 26))

.2 Main Reasons for Develop:

To review Rec.75 and develop a standard set of data to be provided to Flag States.

.3 List of non-IACS Member classification societies contributing through the TC Forum and/or participating in IACS Working Group:

None.

.4 History of Decisions Made:

EG/Data reviewed Rec.75 under task No.1 (Form A approved under subject no: 13101a) and proposed a complete revision to Rec.75.

.5 Other Resolutions Changes

None.

. 6 Any hinderance to MASS, including any other new technologies:

None.

.7 Dates:

Original Proposal: November 2011 (GPG 71 FUA 26)
EG Approval: 24 December 2014 by EG/Data
GPG Approval: 10 February 2015 (Ref: 14209_IGc)

- **New (June 2001)**

Developed by AHG/EACSD in April 2001 (Ref: 0071aLRb) and adopted by Council on 4 June 2001.

Part B. Technical Background

List of Technical Background (TB) documents for Rec.75:



Note: *There are no separate Technical Background (TB) documents for Recommendation No.75 New (June 2001), Rev.1 (Feb 2015), Corr.1 (Feb 2016 Rev.2 (Dec 2016)), Rev.3 (Jan 2020) and Corr.1 (Oct 2020)*

APPENDIX

Main changes introduced in Rec 75 (Rev.3 Jan 2020)

Mapping of data comparing IACS REC 75 Rev.2 and IACS REC 75 Rev.3 (Mapping Data IACS Rec 75 Rev.2 Rev.3 Jan 2020)

Recommendation No.75 REV 3 “Main Changes included in Revision 3”

- **Main changes introduced in Revision 3 of IACS Recommendation 75, compared to Revision 2**

1) Introduce a structure in the data model to facilitate the mapping of the different data and future maintenance (paragraph 2.5 and Appendixes)

2) Eliminate duplication of data:

- Classed Ship and MMS Ship were managed with duplicated data; those were merged into one field SHIPS, the scope of the RO issuing the data being specified in other field

- Due to this merge, some data may not be mandatory for MMS ships as this data may be of competence of another RO ; to address this point, the 'Mandatory' column in Table 1 has been changed to include 3 values :

Y = Mandatory data

N = Not mandatory data

C = Mandatory data for ships classed by the reporting RO

Those fields shall be marked as C: SHIP_Build_Date, SHIP_Keel_Laid_Date, SHIP_Class_Entry_Date, SHIP_Classed_By, SHIP_Class_Number, SHIP_Class_Status, SHIP_Ship_Status, SHIP_Class_Notation, SHIP_Gross_Tons , SHIP_Registered_Owner

3) Rationalize codifications for better data accuracy

- Flags were only defined with ISO code of countries, however some countries have several flags (naval, civilian) and some ships did not have flags; this was modified by enabling to specify with 2 fields the SHIP ADMINISTRATION TYPE and the SHIP ADMINISTRATION COUNTRY

- Ship types (SHIP GENERAL TYPE DESCRIPTION) included a value "ZZ-Other Vessel Type" but it was not possible to provide more information; a field SHIP TYPE DETAILED DESCRIPTION has been added

- Rationalize codification of SHIP_SHIP_STATUS (new status: In Service, Laid Up, Lost from RO's Class)

- Rationalize codification of SHIP CERTIFICATE CODE , to match with naming conventions (remove international from all certificates names as it could be Statement of Compliance, remove CAS, change ISS to ISPS, change SPSS to SPS, change COCDG to DG, change CRGGR to ILO152 ; national certificate to use the international convention code and be prefixed by the country code)

- Align statutory Survey Types to IMO naming (as per IMO resolution A1120 (30))

- Remove the SHIP prefix to objects within SURVEY/AUDITS section and COMMENTS section of the data model as those are also applicable to companies
- Change COMPANY CERTIFICATE NAME to COMPANY CERTIFICATE CODE, enable to indicate if it is an international or national certificate
- EU-MRV, ILO92 and ILO 133, ISO standards included as not mandatory data, stating it is up to the RO as per the RO scope of work and the RO agreement with the flag state to include or not the data
- SURVEY_AUDIT_Type: removal of the status P for Periodical, rationale being that Annual, Intermediate and Renewal surveys are by nature periodical (scheduled) surveys; for this reason, we should avoid defining Periodical as a survey type. As SOLAS defines two surveys denoted 'periodical':
- For the Cargo Ship Safety Equipment Certificate. This shall be performed timewise as an intermediate survey. It should therefore be given the code SE.In.
- For the Cargo Ship Safety Radio Certificate. This shall be performed timewise as an annual survey. It should therefore be given the code SR.A.

4) Enrich the data provided to flag states and facilitate management of certificates

- enrich the COMMENTS section, changed to FINDINGS COMMENTS and covering all types of deficiencies and comments (NC, deficiency, observation, memorandums, recommendations)

5) Reflect GPG policy decision to use the terminology "Condition of Class" (CoC)" and "Statutory Condition" instead of the terms "Recommendation" or "Recommendation / Condition of Class", as per 17044bIGr.

This policy decision will be applicable from July 1st 2020.

Note: in case a condition is linked to both class and statutory matters, the condition will need to be duplicated, 1 line with COMMENT_Type = "C" and 1 line with COMMENT_Type = "S"

6) To secure no data is missed, change the rule for the inclusion of withdrawn certificate data: ("SHIP_CERTIFICATES Data of the certificates/documents issued by the RO for a ship and not yet withdrawn or **withdrawn in the last month**") has been changed to "**withdrawn in the last 2 months**"

7) To facilitate future maintenance, a new Chapter has been added to propose a governance for potential future changes in REC 75.

8) Rationalize document

- former Chapter 3 was deleted as it was not relevant to the scope of REC 75, former chapter 3 was about viewing documents online rather than interfacing data with 3rd parties including flag states.

Parent	Child	List of values
GENERAL DATA	RO	ABS=American Bureau of Shipping BV=Bureau Veritas CCS=China Classification Society CRS=Croatian Register of Shipping IRS=Indian Register of Shipping KR=Korean Register of Shipping LR=Lloyd's Register of Shipping NK=Nippon Kaiji Kyokai PRS=Polish Register of Shipping RINA=RINA Services S.p.A. RS=Russian Maritime Register of Shipping VL=DNV GL Non-IACS members ROs may use other codes and abbreviations.
CLASSED SHIPS	SHIP_Classed_By	ABS=American Bureau of Shipping BV=Bureau Veritas CCS=China Classification Society CRS=Croatian Register of Shipping IRS=Indian Register of Shipping KR=Korean Register of Shipping LR=Lloyd's Register of Shipping NK=Nippon Kaiji Kyokai PRS=Polish Register of Shipping RINA=RINA Services S.p.A. RS=Russian Maritime Register of Shipping VL=DNV GL Non-IACS members ROs may use other codes and abbreviations.
	SHIP_General_Type_d escription	BC - Bulk Carrier (all combinations OB, OBO, OO) CT - Chemical Tanker GC - General Cargo Vessel (including Ro- Ro Cargo, Container, Reefer, HSC Cargo) GT - Gas Tanker LC - Other Bulk Liquid Carrier OT - Oil Tanker PS - Passenger Vessel (including Passenger / General Cargo, Passenger / Ro-Ro, Passenger HSC) ZZ - Other Vessel Type
	SHIP_Class_Status	V=Class valid S=Class suspended W=Class Withdrawn
	SHIP_Ship_Status	E=In service L=Laid Up P=Lost
MMS_SHIPS	SHIP_ISM_Type	BC=Bulk carrier CH=Cargo high speed craft CT=Chemical tanker GC=Gas carrier MO=Mobile offshore drilling unit OC=Other cargo ship OT=Oil tanker PH=Passenger high speed craft PS=Passenger ship PR=Passenger ferry (ro-ro)
SHIP_CERTIFICATE	SHIP_CERTIFICATE_Status	V (Valid), S (Suspended), W (Withdrawn)
	SHIP_CERTIFICATE_Issued_By	same as SHIP_Classed_by
	SHIP_CERTIFICATE_Code	AFS=International Anti-Fouling System Certificate BWM=International Ballast Water Management Certificate CLASS=Classification Certificate DSC=Dynamically Supported Craft Construction and Equipment Certificate HSCS=High-Speed Craft Safety Certificate IBC=International Certificate of Fitness for Dangerous Chemicals in Bulk (IBC Code) BCH=Certificate of Fitness for Carriage of Dangerous Chemicals in Bulk (BCH Code) IGC=International Certificate of Fitness for Carriage of Liquefied Gases in Bulk (IGC Code) GC=Certificate of Fitness for Carriage of Liquefied Gases in Bulk (GC Code) CA=Crew Accommodation Certificate CRGGR=ILO Cargo Gear Certificate INF=International Certificate of Fitness for the Carriage of INF Cargo (INF Code) DOC=Document of Compliance (ISM Code) SMC=Safety Management Certificate (ISM Code) ISS=International Ship Security Certificate ILL=International Load Line Certificate NLL=National* Load Line Certificate IOPP=International Oil Pollution Prevention Certificate NOPP=National* Oil Pollution Prevention Certificate NLS=International Pollution Prevention Certificate for the Carriage of Noxious Liquid Substances in Bulk (NLS Certificate) ISPP=International Sewage Pollution Prevention Certificate IAPP=International Air Pollution Prevention Certificate NAPP=National* Air Pollution Prevention Certificate EFFC=Energy Efficiency Certificate ML=Maritime Labour Certificate MODU=Mobile Offshore Drilling Unit Safety Certificate CRGSS=Cargo Ship Safety Certificate DOCDG=Document of Compliance (Dangerous Goods) (SOLAS Reg II-2/19) SC=Cargo Ship Safety Construction Certificate SE=Cargo Ship Safety Equipment Certificate SR=Cargo Ship Safety Radio Certificate PSS=Passenger Ship Safety Certificate SPSS=Special Purpose Ship Safety Certificate NT=National* Tonnage Certificate IT=International Tonnage Certificate OTHER=Other Certificate NOCRT=Survey handled, but no certificate issued CAS=Conditional Assessment Scheme (*) Relating to National Rules of the Flag State

SHIP_CERTIFICATE_Validity_Type F=Full Term issue
 I=Interim/Unconditional Issue
 S=Short term (a certificate valid for a maximum period of 5 months, issued in order to bridge the time until the Full Term Certificate is received on board)
 C=Conditional (certificate issued when deficiencies exists and it is valid for a period only long enough to permit the ship to proceed to the port where the deficiencies can be rectified)

SHIP_CERTIFICATE_Category S=Standard
 D=Document of compliance

Mapping Rev 2 to Rev 3
 S => IC
 D => C
 C => SoC
 N => C
 F => SoC
 V => SoC

C=Statement of compliance (not on behalf of the flag)

N=Non convention
 F=Statement for Issue
 V=Voluntary

COMPANY CERTIFICATES

COMPANY_CERTIFICATE_Status V (Valid)
 S (Suspended)
 W (Withdrawn)

COMPANY_CERTIFICATE_Name DOC=Document of compliance
 EEMC=Company energy efficiency management certificate
 SRPS=Document of compliance for seafarer recruitment and placement service
 Other certificate types may be defined in the future

COMPANY_CERTIFICATE_Type V=Voluntary
 C=Convention

COMPANY_CERTIFICATE_Validity_Type DOC_status must be one of the following:
 F=Full
 I=Interim
 S=Short-term

COMPANY_CERTIFICATE_Ship_Types BC=Bulk carrier
 CH=Cargo high speed craft
 CT=Chemical tanker
 GC=Gas carrier
 MO=Mobile offshore drilling unit
 OT=Oil tanker
 OC=Other cargo ship
 PH=Passenger high speed craft
 PS=Passenger ship
 PR=Passenger ferry (ro-ro)

SURVEYS /AUDITS

SHIP_SURVEY_Code same as SHIP_CERTIFICATE_Code.
 For the class surveys this shall be "CLASS".

SHIP_SURVEY_Type A=Annual survey, annual survey or periodical inspection;
 AD=Additional/Occasional survey;
 B=Inspection of the outside of the ship's bottom (dry);
 W=Inspection of the outside of the ship's bottom (iws)
 T=Tailshaft (They could be more than one: T1, T2, etc)
 Bo=Boiler (They could be more than one: Bo1, Bo2, etc)
 I=Initial survey;
 IN=Intermediate survey;
 P=Periodical survey;
 R=Renewal survey;
 Int=Interim /pre-audit /pre-verification (for ISM, ISPS, MLC certificates);
 For classification surveys SHIP_SURVEY_Type will be in accordance with the rules, regulations and practice of the particular classification society which has classed the ship.

NEXT

SHIP_SURVEY_Status D=the current date is within the survey range dates.
 O=the current date is after the survey range to date.
 P=the survey has been started but is not yet complete.
 B=before the survey range dates.
 The contents of this field may be calculated at run-time.

COMMENTS

SHIP_COMMENT_Type M="Memorandum"
 R="Recommendation"

SHIP_COMMENT_Status A="Active" - the comment is still applicable.
 P="Postponed" - the comment is still applicable and the due date/expiry survey have been changed.
 O="Overdue" - the comment is still applicable and is also overdue for implementation.

Parent	Child		List of values	Reference
GENERAL DATA	RO	ABS	American Bureau of Shipping	
		BV	Bureau Veritas	
		CCS	China Classification Society	
		CRS	Croatian Register of Shipping	
		IRS	Indian Register of Shipping	
		KR	Korean Register of Shipping	
		LR	Lloyd's Register of Shipping	A1
		NK	Nippon Kaiji Kyokai	
		PRS	Polish Register of Shipping	
		RINA	RINA Services S.p.A.	
		RS	Russian Maritime Register of Shipping	
		VL	DNV GL	
			Non-IACS member ROs may use other codes.	
SHIP DATA	SHIP_Administration_Type	C	Civilian	
		N	Naval	
		O	Other	
		X	None	
		U	Unknown	
	SHIP_Classed_By	ABS	American Bureau of Shipping	
		BV	Bureau Veritas	
		CCS	China Classification Society	
		CRS	Croatian Register of Shipping	
		IRS	Indian Register of Shipping	
		KR	Korean Register of Shipping	
		LR	Lloyd's Register of Shipping	A1
		NK	Nippon Kaiji Kyokai	
		PRS	Polish Register of Shipping	
RINA		RINA Services S.p.A.		
RS	Russian Maritime Register of Shipping			
VL	DNV GL			
	Non-IACS member ROs may use other codes.			
SHIP_Type_IACS	BC	Bulk carrier (all combinations OB, OBO, OO)		
	CT	Chemical tanker		
	GC	General cargo vessel (including ro-ro cargo, container, reefer, HSC cargo)		
	GT	Gas tanker	A2	
	LC	Other bulk liquid carrier		
	OT	Oil tanker		
	PS	Passenger vessel (including Passenger/General cargo, Passenger/ro-ro, Passenger HSC)		
ZZ	Other vessel type			
SHIP_Class_Status	V	Class valid		
	S	Class suspended		
	W	Class withdrawn		
SHIP_Ship_Status	E	In service		
	L	Laid up		
	P	Lost from RO's class		
SHIP_Type_MMS	BC	Bulk carrier		
	CH	Cargo high speed craft		
	CT	Chemical tanker		
	GC	Gas carrier		
	MO	Mobile offshore drilling unit	A3	
	OC	Other cargo ship		
	OT	Oil tanker		
	PH	Passenger high speed craft		
	PS	Passenger ship		
PR	Passenger ferry (ro-ro)			
CERTIFICATE_DATA	CERTIFICATE_Status	V	Valid	
		S	Suspended	
		W	Withdrawn	
	CERTIFICATE_Issued_By	Same as SHIP_Classed_by		A1
	CERTIFICATE_Code	AFS	<> Anti-Fouling System <>	Vessel
		BWM	<> Ballast Water Management <>	Vessel
		CL	Classification <>	Vessel
		DSC	Dynamically Supported Craft Construction and Equipment <>	Vessel
		EU-MRV	Monitoring, reporting, and verification of carbon dioxide emissions <>	Vessel
		HSC	<> High-Speed Craft Safety <>	Vessel
		IBC	<> of Fitness for the Carriage of Dangerous Chemicals in Bulk	Vessel
		IGC	<> of Fitness for the Carriage of Liquefied Gases in Bulk	Vessel
		ILO92	ILO92 <> - Crew Accommodation	Vessel
		ILO133	ILO133 <> - Crew Accommodation	Vessel
ILO152		ILO152 <> - Cargo Gear	Vessel	
INF		<> of Fitness for the Carriage of INF Cargo	Vessel	
DOC		<> Safety Management <>, Company	Company	
SMC		<> Safety Management <>, Vessel	Vessel	
ISPS		<> Ship Security <>	Vessel	
ISO9001		Quality management system <>	Company	
ISO14001		Environmental management system <>	Company	
ISO45001		Occupational health and safety management system <>	Company	
ISO50001		Energy management system <>	Company	
LL		<> Load Line <>	Vessel	
OPP		<> Oil Pollution Prevention <>	Vessel	
NLS		<> Pollution Prevention <> for the Carriage of Noxious Liquid Substances in Bulk	Vessel	
SPP		<> Sewage Pollution Prevention <>	Vessel	
GPP		<> Garbage Pollution Prevention <>	Vessel	
APP		<> Air Pollution Prevention <>	Vessel	
EE		<> Energy Efficiency <>	Vessel	
FDACS		<> Fuel Oil Consumption Reporting <>	Vessel	
MLC		Maritime Labour <>	Vessel	
MODU		Mobile Offshore Drilling Unit Safety <>	Vessel	
POLAR		Polar Ship <>	Vessel	
CSS		Cargo Ship Safety <>	Vessel	
DG		<> for the Carriage of Dangerous Goods	Vessel	
SC		Cargo Ship Safety Construction <>	Vessel	
SE	Cargo Ship Safety Equipment <>	Vessel		
SR	Cargo Ship Safety Radio <>	Vessel		
PSS	Passenger Ship Safety <>	Vessel		
SPS	Special Purpose Ship Safety <>	Vessel		
TM	<> Tonnage <>	Vessel		
OTHER	<>	Vessel		

CERTIFICATE_Validity_Type	F	Full term issue	
	I	Interim/unconditional issue	
	S	Short term (a certificate valid for a maximum period of 5 months, issued in order to bridge the time until the full term certificate is received on board).	
	C	Conditional (certificate issued when deficiencies exist and it is valid for a period only long enough to permit the ship to proceed to the port where the deficiencies can be rectified)	
CERTIFICATE_Category	IC	Use when: a. the regulation is an international convention or mandatory referenced code, and b. the regulation has entered into force, and c. the regulation is ratified by the Administration, and d. the regulation applies to the vessel/company, and e. the Administration has authorised the issuing organization to issue the certificate.	
	C	Use when: a. the Administration has authorized the issuing organization to issue the certificate, and b. not all conditions a - d for IC are met.	
	SoC	Use when: a. the flag state has not authorised the issuing organisation to issue the certificate	

COMPANY_CERTIFICATE_Ship_Types	BC	Bulk carrier	
	CH	Cargo high speed craft	
	CT	Chemical tanker	
	GC	Gas carrier	
	MO	Mobile offshore drilling unit	
	OC	Other cargo ship	A3
	OT	Oil tanker	
	PH	Passenger high speed craft	
	PS	Passenger ship	
	PR	Passenger ferry (ro-ro)	

SURVEY_AUDIT_DATA	SURVEY_AUDIT_Code	BOT	For bottom surveys		
		B	Inspection of the outside of the ship's bottom (dry)		
		W	Inspection of the outside of the ship's bottom (iws)		
		Tx	Tailshaft (x to enable to code several tailshafts T1, T2, etc)		
		Box	Boiler (x to enable to code several boilers Bo1, Bo2, etc)		
			For statutory surveys/audits, use the CERTIFICATE_Code given by Appendix Table A4. For other class surveys, use the coding of the ship's recognised organization	A4	(see CERTIFICATE_Code above in line I73)

SURVEY_AUDIT_Type	A	Annual	Scheduled
	F	Final	Un-scheduled
	I	Initial	Un-scheduled
	In	Intermediate	A5 Scheduled
	It	Interim	Un-scheduled
	O	Occasional	Un-scheduled
	R	Renewal	Scheduled

NEXT	SURVEY_AUDIT_Status		To be filled in only for surveys/audits not yet carried out or completed. The contents of this field may be calculated at run-time.
		D	The current date is within the survey/audit range dates.
		O	The current date is after the survey/audit range to date.
		P	The survey/audit has been started but is not yet complete.
		B	Before the survey/audit range dates.

FINDING_COMMENT_DATA	COMMENT_Type	M	Memorandum
		C	Condition of Class
		S	Statutory condition
		N	Non-conformity
		D	Deficiency
		O	Observation
COMMENT_Status	A	Active: the comment is still applicable.	
	P	Postponed: the comment is still applicable and the due date/expiry survey have been changed.	
	O	Overdue: the comment is still applicable and is also overdue for implementation.	

Recommendation No.77

“Guidelines for the Surveyor on how to Control the Thickness Measurement Process”

Part A. Revision History

Version no.	Approval date	Implementation date when applicable
Rev.4 (Oct 2017)	15 October 2017	-
Rev.3 (Oct 2016)	05 October 2016	-
Rev.2 (Apr 2006)	12 April 2006	
Rev 1 (July 2004)	29 July 2004	-
New (Mar 2002)	27 March 2002	-

• Rev 4 (Oct 2017)

.1 Origin of Change:

- Suggestion by an IACS member

.2 Main Reason for Change:

A Survey Panel Member proposed to revise PR19 to provide clarity by specifying the applicability of mobile offshore drilling units (MODU). The relevant text in Recommendation 77 is suggested to be aligned with the PR19 (Rev.1) by GPG.

.3 List of non-IACS Member Classification Societies contributing through the TC Forum and/or participating in IACS Working Group:

None

.4 History of Decisions Made:

The proposed amendments were discussed and agreed under the task PSU17015.

The relevant text in Recommendation 77 was aligned with the corresponding text in the revised PR 19 Rev.1. A footnote was added to the control process. MODU and Z15 were added to the para. 1.

No TB has been expected for this revision.

.5 Other Resolutions Changes:

UR Z17, PR19

.6 Dates:

Panel Approval: 12 September 2017 (Ref: PSU17015)
GPG Approval: 15 October 2017 (Ref: 16161aIGd)

- **Rev 3 (Oct 2016)**

.1 Origin of Change:

- Suggestion by an IACS member

.2 Main Reason for Change:

The list of the participants to kick-off meeting is not aligned to that set in paragraph 2.1 of IACS Procedural Requirement 19 (which took effect from 1st January 2010).

.3 List of non-IACS Member Classification Societies contributing through the TC Forum and/or participating in IACS Working Group:

None

.4 History of Decisions Made:

Survey Panel initiate the discussion the revision of the Recommendation 77 under Panel Task PSU16034 and Members agreed that the provisions set in IACS PR19 need to be reflected in to the IACS Recommendation 77.

For the modification of the 1st period two proposals of updating have been analysed and processed by the Members.

No qualified majority has been expressed for any of the two but the majority of the Members has clearly indicated the preference for the one listing the participants, to the kick-off meeting, according to the order used in the Procedural Requirement 19

By considering that:

- the participants to the kick-off meeting listed into the ESP Code and the PR19 are the same and that the only difference is the order of listing,
 - no dissenting views have been received
- the modification has been considered agreed by the Panel.

Three typo errors found in the text of revision 2 has been corrected.

No TB has been expected for this revision.

.5 Other Resolutions Changes:

Nil

.6 Dates:

Panel Approval: 09 September 2016 (Ref: PSU16034)

GPG Approval: 05 Oct 2016 (Ref: 16161_IGb)

- **Rev 2 (Apr 2006)**

Survey Panel Task 36: Amend Recommendation 77 to reflect changes to PR19. (Ref 5031gIGe)

1. Paragraph 2.4 "shall" replaced "should"
2. Paragraph 3.6 as shown in 5031jBVa added.

- **Rev 1 (July 2004)**

Subject no. 4072, WP/SRC Task 144. Amendment re signature of TM report. UR Z 7.1 and Z10s also to be amended per 4072cNVa 11/05/04.

- **New (Mar 2002)**

WP/SRC submitted a draft Rec to GPG for approval. PR19 (Rev.1) and Rec 77 were approved on 27 March 2002 (0065i)

Part B. Technical Background

List of Technical Background (TB) documents for Rec. 77:

Note:

1) There are no separate Technical Background (TB) documents for New (March 2002), Rev.1 (July 2004), Rev.2 (Apr 2006), Rev.3 (Oct 2016) and Rev.4 (Oct 2017).

Recommendation No: 79

“Guidance for Anchoring Equipment in Service”

Part A. Revision History

Version no.	Approval date	Implementation date when applicable
Rev.1 (July 2014)	15 July 2014	-
New (July 2003)	14 July 2003	-

- **Rev.1 (July 2014)**

1 Origin for Change:

- Suggestion by IACS Member

.2 Main Reasons for Change:

To clarify guidance/requirements for loose studs in anchor cable, looseness and diminution criteria in kenter and other joining links, and looseness criteria for anchor pins. Accordingly, update Rec. 79 or UR A1 as deemed appropriate.

.3 List of non-IACS Member classification societies contributing through the TC Forum and/or participating in IACS Working Group:

None.

.4 History of Decisions Made:

The task was triggered by an IACS member following imposition of a Condition of Class on loose studs in anchor cable on a tanker, leading to chartering difficulties and an owner complaint on the lack of criteria for such looseness.

The task was augmented by members to include kenter and other cable links' acceptance criteria, and anchor pin clearances.

Panel discussed and agreed to update Rec. 79 to clarify the acceptance criteria of anchoring equipment in service. Accordingly, Panel revised the title of the Rec 79 in order to make it consistent with the guidance additionally included to this revised IACS Recommendation. Panel also concluded to include terminologies of different anchoring equipment with figures as an annex to this guidance for better clarification.

.5 Other Resolutions Changes

None

.6 Dates:

Original Proposal: 6 October 2011 by Survey Panel Member

Survey Panel Approval: 8 March 2013 during 17th Survey Panel Meeting
GPG Approval: 15 July 2014 (Ref: 12007_IGg)

- **New (July 2003)**

Proposed by WP/MW and approved at GPG 54.

Part B. Technical Background

No Technical Background (TB) documents are available for Rec.79 New (July 2003) and Rev.1 (July 2014).

Recommendation No.80 "Containers "In One Door Off" Operation"

Part A. Revision History

Version no.	Approval date	Implementation date when applicable
Del (Jan 2013)	30 January 2013	-
New (July 2003)	14 July 2003	-

- **Del (Jan 2013)**

.1 Origin for Change:

- Suggestion by an IACS Member (refer GPG 73 FUA 8)

.2 Main Reason for Change:

IMO resolution MSC.310(88), which entered into force on 1 January 2012, now clearly indicates the information to be provided on the CSC Safety Approval Plate in case of ONE DOOR OFF OPERATION relating to stacking and racking tests (new section 8 of Annex II of CSC 1972, as amended). It is also noted that DSC 17 agreed further draft amendments to CSC 1972, as amended, which were approved at MSC 91, with a view to subsequent adoption. These new draft amendments, inter alia, update the CSC provisions in such a way that it is considered that IACS Recommendation 80 is no longer considered necessary.

.3 List of non-IACS Member Classification Societies contributing through the TC Forum and/or participating in IACS Working Group:

None

.4 History of Decisions Made:

GPG 73 discussed the matter and tasked Statutory Panel to consider this further. Statutory Panel proposed the deletion of Rec.80. GPG accepted the proposal.

.5 Other Resolutions Changes

None

.6 Dates:

Original Proposal: October 2012 made by a Member
 Panel Approval: 11 December 2012 by Statutory Panel
 GPG Approval: 30 January 2013 (Ref: 12220_IGc)

- **New (July 2003)**

No records available

Part B. Technical Background

List of Technical Background (TB) documents:

There are no separate technical background (TB) documents available for New (July 2003) and Del (Jan 2013).

Recommendation No. 82

“Surveyor’s Glossary Hull Terms & Hull Survey Terms”

Summary:

For aligning with the descriptions of the forepeak and afterpeak tanks in the UR Z7 Table 1 as revised by the Rev. 27 of UR Z7, Survey Panel revised the relevant text in the definition of “Aft Peak Bulkhead” in Recommendation 82.

Part A. Revision History

Version no.	Approval date	Implementation date when applicable
Rev.1 (Oct 2018)	28 October 2018	-
New (July 2003)	July 2003	-

• Rev.1 (Oct 2018)

.1 Origin of Change:

- Suggested by IACS member

.2 Main Reason for Change:

To revise Rec.82 for aligning with the descriptions of the forepeak and afterpeak tanks in the UR Z7 Table 1 as revised by the Rev. 27 of UR Z7.

.3 List of non-IACS Member classification societies contributing through the TC Forum and/or participating in IACS Working Group:

None

.4 History of Decisions Made:

A member noted that the description of current FP and AP tanks in UR Z7 Table 1 and Rec.82 are not completely accurate and recommended to be revised.

During the 27th Survey Panel Meeting, the members reviewed the UR Z7 & Rec.82 and agreed to modify the definition of Aft Peak Bulkhead in Rec.82 as “Aft Peak Bulkhead is a term applied to the first main transverse watertight bulkhead forward of the stern. ~~The An~~ aft peak tank is the compartment any tank in the narrow part of the stern aft of this last watertight bulkhead.”

During the 28th Survey Panel Meeting, the members finalized the revisions of UR Z7 and Rec. 82 and their HFs.

No TB is expected for the present revision.

.5 Other Resolutions Changes

UR Z7

.6 Dates:

Original Proposal: 07 December 2017 Made by a Survey Panel Member

Panel Approval: 12 October 2018 (Ref: PSU17044)

GPG Approval: 28 October 2018 (Ref: 18160_IGc)

- **New (2003)**

No history files or TB document available.

Part B. Technical Background

List of Technical Background (TB) documents for Rec 82:

Note: *There are no separate Technical Background (TB) documents for New (2003), and Rev.1 (Oct 2018).*

Recommendation No.84 “CONTAINER SHIPS - Guidelines For Surveys, Assessment and Repair of Hull Structure”

Part A. Revision History

Version no.	Approval date	Implementation date when applicable
Rev.1 (Nov 2017)	08 November 2017	-
New (2005)	2005	-

• Rev.1 (Nov 2017)

.1 Origin for Change:

- Request by non-IACS entity (Bahamas Administration)
- Other (Periodical review of IACS resolutions)

.2 Main Reason for Change:

This task was initiated in order to provide the revision of the IACS Rec. 84 as permanent task of the Survey Panel. In addition to this the Permanent Secretariat of IACS highlighted that the Administration of Bahamas sent a query to IACS regarding the possible revision of the Rec. 84. Survey Panel discussed the issue and agreed to establish a PT to review and amend Rec. 84.

.3 List of non-IACS Member Classification Societies contributing through the TC Forum and/or participating in IACS Working Group:

None

.4 History of Decisions Made

Survey Panel discussed the revision of the Recommendation 84 under Panel Task PSU15044.

PT PSU28/2016 was established, and made revisions mostly addressing the following:

- modification of some paragraphs of general part and some sketches of proposed repairs, so that they are aligned to those contained in the other IACS Recommendations relevant to guidelines for surveys, assessment and repair of hull structure of other types of ships, such as Rec. 55 Rev.1;
- modification of some paragraphs of general part, for aligning with the present requirements of UR Z3 and Z7;
- modification of some paragraphs with the reference to UR S33, Part B of Rec 47 and IMO Circular MSC/Circ. 1087 (IACS UI LL64);

- modification of some sketches with more detailed typical damages or repair methods;
- addition of some sketches of typical damages and repairs with the references to the examples;
- add a new paragraph providing survey guidelines upon the review of the IMO documents MSC 93/INF.14 and MSC 95/INF.11, the interim and final investigation reports of M.V. "MOL COMFORT", as proposed by IMO documents MSC 93/9/2 and MSC 95/16, for large container ships (8,000 TEU or over) not subject to the structure assessments as per IACS UR S11A;
- add a new paragraph providing survey guidelines about steel renewal for structures subject to net scantling approach as per the Unified Requirements of IACS (Refer to UR S11A and S21A).

During the 25th Survey Panel meeting, the proposed actions by PT to the comments of panel members were reviewed and agreed by the panel subject to some wordings and sketches to be further revised by PT. Following the PT revised the draft Rec.84 according to the FUAs of 25th Survey Panel meeting, Survey Panel members agreed the modifications and finalized the revision 1 at 26th Survey Panel meeting.

No TB has been expected

.5 Other Resolutions Changes

None

.6 Dates:

Original Proposal: 14 September 2017 by Non IACS Entity

Panel Approval: 23 October 2017 (Ref: PSU15044).

GPG Approval: 08 November 2017 (Ref: 16017_IGh)

- **New (2005)**

No history files or TB document available.

Part B. Technical Background

List of Technical Background (TB) documents for Rec.84:

Note: *There are no separate Technical Background (TB) documents for New (2005) and Rev. 1 (Nov 2017).*

Recommendation No.85 “Recommendation on Voyage Data Recorder”

Summary:

This is an existing document, offering interpretation of SOLAS, IMO MSC Res. & IGC Code (MSC.5(48) as amended) with respect to VDR installations. The necessity of revision was agreed by IACS members for alignment with the revised (amended) IGC Code (MSC.370 (93)) as well as with updated IMO Resolutions (such as MSC.333(90) and A.1021(26)).

Part A. Revision History

Version no.	Approval date	Implementation date when applicable
Rev.1 (Dec 2018)	21 December 2018	-
New (Jan 2005)	January 2005	-

• Rev.1 (Dec 2018)

.1 Origin of Change:

- GPG request (15042_IGd)
- Suggestion by an IACS member for further revision for alignment with updated IMO Resolutions.

.2 Main Reason for Change:

In the light of the revised IGC Code (MSC.370(93)), GPG tasked IACS panel members to review the applicable URs, UI's & REC's and propose revision, deletion or amendment of the application statement, as appropriate within the scope of the standing task "maintenance of IACS Resolutions".

It was noted that interpretations as provided in REC. No. 85 required amendments for consistency with the revised IGC Code (MSC.370(93)); to this end it was proposed by panel members that existing REC. No.85 is to be revised.

On the occasion of the alignment with the amended IGC Code, further revision for alignment with updated IMO performance standards for VDR (Res. MSC.333(90)) and Code on Alerts and Indicators (Res.A.1021(26)) was agreed by the Panel.

.3 List of non-IACS Member Classification Societies contributing through the TC Forum and/or participating in IACS Working Group:

None

.4 History of Decisions Made:

This task was triggered by the Machinery Panel during 22nd meeting under PM5901-Maintenance of IACS resolutions.

The Machinery Panel has been requested by GPG to review applicable URs, UIs and RECs under its responsibility as the text in the original IGC code has been revised and the new IGC code has been adopted (Resolution MSC. 370(93)) and where necessary propose revision, deletion or amendment of the application statements, taking into account that GPG is in favour of the retention of UR/UI's relating to the older IGC Code.

.5 Other Resolutions Changes

- UI GC2
- UI GC9
- UI SC6
- REC.114

.6 Dates:

Original Proposal: September 2015 (22nd Machinery Panel Meeting)

Panel Approval: 29 November 2018 (Ref: PM5901fIMn)

GPG Approval: 21 December 2018 (Ref: 15042_IGze)

- **New (Jan 2005)**

No records available.

Part B. Technical Background

List of Technical Background (TB) documents for Rec.85:

Annex 1. **TB for Rev.1 (Dec 2018)**

See separate TB document in Annex 1.

Note: There is no separate Technical Background (TB) document for New (Jan 2005).

Technical Background (TB) document for Rec 85 (Rev.1 Dec 2018)

1. Scope and objectives

Alignment of Rec. No. 85 with the amended IGC Code (Res. MSC.370(93)) and with updated IMO documents pertaining to VDR performance standards and installations.

2. Engineering background for technical basis and rationale

- The initial version of Rec.85 (Jan 2005) contains tables with alarms recommended to be recorded by the VDR if the alarms are located on the bridge, with one of the Tables referring to sections of the superseded IGC Code. Following the entry into force of the amended IGC Code (Res. MSC.370(93)) as of 1 January 2016, consideration was given to possible revision of the specific Table (7.9.7 in the initial version of Rec.85) to refer to sections of the amended IGC Code. Consideration was also given to any additional requirement for alarms per the amended IGC Code (such as the Overflow Control alarm in regulation 13.3.7).
- IMO issued in 2012 revised performance standards applicable to VDRs installed on or after 1 July 2014. Paragraphs based on or making reference to the previous standard A.861(20), as amended, need an update.
- Based on amendments/updates to SOLAS, FSS Code, IBC Code and the Code on Alerts and Indicators, all sections of the Recommendation referring to older editions of IMO Instruments have been also reviewed aiming at further revision.

3. Source/derivation of the proposed IACS Resolution

The following IMO documents have been the source for the revision together with the various amendments to SOLAS Chapters II-1, II-2, IV and XII and to the FSS Code:

- Res.MSC.370(93) "Amendments to the International Code for the Construction and Equipment of Ships Carrying Liquefied Gases in Bulk (IGC Code)";
- Res. MSC.333(90) "Adoption of Revised Performance Standards for Shipborne Voyage Data Recorders (VDRs)";
- Res. A.1021(26) "Code on Alerts and Indicators".

4. Summary of Changes intended for the revised Resolution:

Introductory paragraph: A clause is added clarifying that the revised recommendations apply to VDRs installed on/after 1 July 2014 and that VDRs installed before that date, Res. A.861(20), as amended, applies. The paragraph on Simplified VDRs has been removed as an S-VDR applies to cargo ships constructed before 1 July 2002 only (SOLAS V/20.2).

The following sections have been updated as follows:

- Section 1: "Res. A.861(20)" has been replaced by "Res. MSC.333(90)";
- Section 2: The "final" recording medium has been replaced by "fixed" recording medium, float-free recording medium in its float-free capsule and long-term recording medium per the definitions of Res. MSC.333(90);
- Section 3.1: Reference to Res. A.861(20), 5.3.3, has been replaced by a reference to Res. MSC.333(90), Annex, 5.1.3 – Paragraph for recording for at least 12 hours before survey rearranged;
- Section 3.2: Paragraph 10 of UR Z17, Annex 1, has been corrected to read Paragraph 9;
- Section 4.1: Header "Protective Capsule" has been replaced by "Fixed and float-free recording medium" – Last sentence on the float-free capsule has been rearranged to include the minimization of the interference by radar beam;
- Section 4.2: Wording of 5.5.5 of the Annex to Res. MSC.333(90) is adopted;
- Section 4.4: "Res. MSC.333(90), Annex, 5.1.3" has been added;
- Section 5: The main source of power supply has been added together with the 2-hour duration for the dedicated reserve source of electrical power (see 5.4 of the Annex to Res. MSC.333(90)). The last paragraph has been replaced by a new one clarifying the continuous recording unless automatically terminated per 5.4.3 and 5.4.2 of the Annex to Res. MSC.333(90);
- Section 6: Reference to 8 of the Annex to Res. MSC.333(90) has been added;
- Section 7.1: The wording of 5.5.1 of the Annex to Res. MSC.333(90) replaced the complete paragraph.
- Section 7.3: "Speed through water or speed over ground" now reads "Speed through water *and* speed over ground" per 5.5.3 of the Annex to Res. MSC.333(90) – Clarification for the speed "over ground" and for the acronym EPFS has been added to the closing sentence;
- Section 7.7: Footnote 4 for SVDRs has been deleted;
- Section 7.8: ECDIS installation is addressed together with an interpretation in case multiple ECDIS are installed and it is not possible to determine which ECDIS image is used as a primary means of navigation;
- Section 7.9: New paragraph numbering (previous 7.8)
- Section 7.10 (previous section 7.9 on Main Alarms is now renumbered as 7.10): A reference to Table 10.1.1 of the Code on Alerts and Indicators (Res. A.1021(26)) replaced the previous reference to statutory instruments, to A.861(20) and to previous Alarms and Indicators Code (Res.A.830(19)). Based on the new reference all lists in 7.9.1 to 7.9.8 (previous numbering) have been deleted;

- Section 7.11: New paragraph numbering (previous 7.10);
- Section 7.12: New paragraph numbering (previous 7.11) – “Thruster” has been added to the header;
- Section 7.13: New paragraph numbering (previous 7.12) – SOLAS Regulation and applicability have been revised. – Comment under asterisk has been removed.
- Section 7.14: New paragraph numbering (previous 7.13) - SOLAS Regulations and applicability have been revised;
- Section 7.15: New paragraph numbering (previous 7.14);
- Section 7.16: New paragraph numbering (previous 7.15);
- Section 7.17 (new): AIS data recording is addressed (5.5.17 of the Annex to Res. MSC.333(90));
- Section 7.18 (new): Connection to an electronic inclinometer, if installed, is addressed ((5.5.18 of the Annex to Res. MSC.333(90) and Res. 363(92), item 11 (Annex));
- Section 7.19 (new): Electronic logbook information recording is addressed (5.5.20 of the Annex to Res. MSC.333(90));
- Section 7.20: New paragraph numbering (previous 7.16); in addition wording “below 12 hours of data” has been deleted as Section 3.1 specify the requirements for the recording period.

5. Points of discussions or possible discussions

During the initial review for alignment with the amended IGC Code, the following suggestions were made for revision of the Table of previous section 7.9.7:

Sr. No.	Previous IGC Code (MSC. 5(48) regulations	IGC Code (MSC. 370(93)) Changes sought
1	13.4.1 (High & low pressure in cargo tank)	13.4.2
2	13.6.4; Reg. 17.9 (Gas detection equipment)	13.6.13; Reg. 17.9 deleted
3	13.5.2 (Hull or insulation temperature)	13.7.2.2
4	17.18.4.4 (Cargo high pressure, or high temperature at discharge of compressors)	17.16.4.4
5	17.14.4.3 (Gas detection system monitoring chlorine concentration)	17.13.4.3
6	17.14.4.4 (High Pressure in chlorine cargo tank)	17.13.4.4

7	5.2.1.7 (Liquid cargo in ventilation system)	5.2.2.4
8	8.4.2.1 (Vacuum protection of cargo tanks)	8.3.1.1
9	17.14.1.4 (Gas detection after bursting disk for chlorine)	17.13.1.4
10	(Overflow Control)	Addition of 13.3.7

During the subsequent review for alignment with the various amendments of IMO Instruments, the following revisions have been suggested for the Tables of the Recommendation:

7.9.2 SOLAS II-1

Reference	Alarm	Applicability	Comments
15.13.7.3.1	Watertight door low hydraulic fluid level or gas pressure or loss of stored energy in hydraulic accumulator for centralized hydraulic system	Passenger ships constructed on or after 1 February 1992 <u>1 January 2009</u>	
15.13.7.3.2	Watertight door low gas pressure (group alarm), loss of stored energy for each independent hydraulic system	Passenger ships constructed on or after 1 February 1992 <u>1 January 2009</u>	
15.13.7.8	Watertight door electrical power supply loss	Passenger ships constructed on or after 1 February 1992 <u>1 January 2009</u>	
17-1.1.2 <u>20-2.1/2</u>	Watertight integrity from the ro-ro deck to spaces below	Ro-Ro passenger ships <u>constructed on or after 1 January 2009</u>	<u>Vehicle Ramps giving access to spaces below the bulkhead deck</u>

<u>17-1.1.3</u>	<u>Particular accesses to spaces below the bulkhead deck</u>	<u>Ro-Ro passenger ships constructed on or after 1 January 2009</u>	
<u>17-1.2</u>	<u>Bow, inner, stern ramp or any other shell door</u>	<u>Ro-ro passenger ships constructed on or after 1 January 2009</u>	<u>Door open or locking device not secured.</u>
<u>22-1</u>	<u>Flooding detection systems</u>	<u>Passenger ships carrying 36 or more persons constructed on or after 1 July 2010</u>	<u>MSC.1/Circ. 1291</u>
<u>25.3</u>	<u>Water level detectors</u>	<u>Single hold cargo ships other than bulk carriers. See Reg. 25.1, 25.2 and 25.4 for application</u>	<u>Need not be fitted in ships complying with XII/12</u>

New Tables on SOLAS Chapters IV and XII have been suggested as follows:

<u>Reference</u>	<u>Alarm</u>	<u>Applicability</u>	<u>Comments</u>
<u>19.2.2.3</u>	<u>Bridge Navigational Watch Alarm System (BNWAS)</u>		<u>Mandatory for VDR installations on/after 1 July 2014 per MSC.333(90)</u>

<u>Reference</u>	<u>Alarm</u>	<u>Applicability</u>	<u>Comments</u>
<u>12.2</u>	<u>Hold, ballast and dry space water ingress alarms (pre-alarm and main alarm)</u>	<u>Bulk Carriers</u>	

In the previous Tables on FSS Code (Res. MSC.98(73)) and on IMO Resolutions, the following revisions have been suggested:

RESOLUTION MSC.98(73) as amended by MSC.206(81), MSC.217(82), MSC.292(87), MSC.311(88), MSC.327(90), MSC.339(91), MSC.367(93)

<u>Reference</u>	<u>Alarm</u>	<u>Applicability</u>	<u>Comments</u>
<u>9.2.5.1.4 2</u>	<u>Fire detection and fire alarm operation</u>		<u>If located on the bridge</u>

10.2.4.1.4 <u>2</u>	Detection of smoke		If located on the bridge
15.2.4.3 2.4, 2.3.2, <u>2.4.2</u>	Inert gas system alarms	Tankers	If located on the bridge
<u>16.2.2.3.3</u>	<u>Fixed Hydrocarbon Gas Detection Systems</u>	<u>oil tankers of 20,000 tonnes deadweight and above, constructed on or after 1 January 2012</u>	<u>cargo pump-rooms subject to the provisions of 5.10 need not comply with</u>

IMO Resolutions

Reference	Alarm	Applicability
A.481(12) A.830(19) 7.1.1 <u>1021(26)</u> Table <u>10.1.1</u>	Personnel alarm (dead man alarm)	If provided Ships except warships, naval auxiliaries, fishing vessels, pleasure yachts, wooden

Bulk Carriers

Reference	Alarm conditions	Comments
MSC.145(77) <u>188(79)</u> 3.3.6, 3.3.7, 3.3.8	Deactivation of water level detectors	If located on the bridge
MSC.145(77) <u>188(79)</u> 3.3.6, 3.3.7, 3.3.8	Failure of water level detector system	If located on the bridge
MSC.145(77) <u>188(79)</u> 3.3.6, 3.3.7, 3.3.8	Failure of electrical power supply to water level detector system	If located on the bridge

In connection with the suggestions in a and b above, the latest agreed revised Rec.85 removed all lists from section "Main Alarms".

A suggestion was made by a member society for reference to Res. A.861(20) for VDRs installed on gas carriers before 1 July 2014, in conjunction with the applicable IGC Code editions; however, as Rec.85 is not limited to gas carriers, a more general comment has been preferred in the introductory section of the document referring to Res.A.861(20).

6. Attachments if any

None

Recommendation No. 86

Applicable Standards for UR P4.7 “Requirements for Type Approval of Plastic Pipes”

Summary

As a follow up of the revision five (5) of the UR P4 it was found that there was the need to update the reference to the typical standards for Tests Nos 1 to 4 in Table 2 of Recommendation 86 (Rev.1, June 2018).

Part A. Revision History

Version no.	Approval date	Implementation date when applicable
Rev.2 (Mar 2019)	20 March 2019	-
Rev.1 (Jun 2018)	12 June 2018	-
New (Feb 2005)	February 2005	-

• Rev.2 (Mar 2019)

.1 Origin for Change:

- Suggested by IACS member

.2 Main Reasons for Change:

As a follow up of the revision five (5) of the UR P4 it was found that there was the need to update the reference to the typical standards for Tests Nos 1 to 4 in Table 2 of Recommendation 86.

.3 List of non-IACS Member Classification Societies contributing through the TC Forum and/or participating in IACS Working Group:

None

.4 History of Decisions Made:

- 1) Test No. 1 in Table 2: the text “IMO Res. A.753(18), Appendix 1, 2” has been replaced with the text “IMO Res. A.753(18), as amended, Appendix 1, 2”
- 2) Test No. 2 in Table 2: the text “UR P 4.4.2” has been replaced with the text “IMO Res. A.753(18), as amended, Appendix 3”
- 3) Tests Nos. 3 and 4 in Table 2: the text “IMO Fire Test Procedures Code” has been replaced with text “IMO Res.A.753(18), as amended, Appendix 3”

.5 Other Resolutions Changes

None

6 Any hinderance to MASS, including any other new technologies:

None

.7 Dates:

Original Proposal: 17 December 2018 (Ref. 16035aIGb)
Panel Approval: 28 February 2019 (Ref: PM15907cIMc)
GPG Approval: 20 March 2019 (Ref: 16035aIGd)

• **Rev.1 (Jun 2018)**

.1 Origin for Change:

Suggested by IACS member

.2 Main Reasons for Change:

The checking and updating of international standards that referenced by IACS resolutions has been carried out by Machinery panel. As a result, it is found that there is a need to update the international standards that referred in the IACS resolution Rec 86.

.3 List of non-IACS Member Classification Societies contributing through the TC Forum and/or participating in IACS Working Group:

None

.4 History of Decisions Made:

Delete the edition year of the ISO standards referenced.

.5 Other Resolutions Changes

None

.6 Dates:

Original Proposal: 22 May 2015, made by Machinery Panel
Panel Approval: 11 May 2018 (Ref: PM5901)
GPG Approval: 12 June 2018 (Ref: 18082_IGc)

• **New (Feb 2005)**

No records available.

Part B. Technical Background

List of Technical Background (TB) documents for Rec 86:

Annex 1. **TB for Rev.1 (Jun 2018)**

See separate TB document in Annex 1.

Annex 2. **TB for Rev.2 (Mar 2019)**

See separate TB document in Annex 2.



Note: *There is no Technical Background (TB) document available for New (Feb 2005).*

Technical Background (TB) document for Rec 86 (Rev.1 June 2018)

1. Scope and objectives

To make amendment to Rec 86 in order to update the international standards that referenced in this IACS resolutions.

2. Engineering background for technical basis and rationale

None.

3. Source / derivation of the proposed IACS Resolution

The task of checking and updating of international standards that referenced by IACS resolutions carries out every five years. From 21st Meeting of IACS MP, the working scope extended from IEC standards referenced to all MP related international standards.

Additionally, it was considered that the "note" should not apply just to tests 1, 2 and 5 in table 2 as all tests in table 2 are optional depending on location and service. In addition, the note should state 'not carried out' in place of 'carried out'.

4. Summary of Changes intended for the revised Resolution

None

5. Points of discussions or possible discussions

After discussion, the edition year for the standards referenced in the original version has been removed, the panel agrees that while it would be good to reference a specific year (or version), nevertheless this may result in additional work to review and amend the IACS documents every time an update to an external standard is published. It is therefore preferred that in general the reference does not include the year/version such that the IACS documents always refer to the latest standard (unless there are specific reasons to refer to a particular version).

6. Attachments if any

None

Technical Background (TB) document for Rec 86 (Rev.2 Mar 2019)

1. Scope and objectives

As a follow up of the revision five (5) of the UR P4 it was found that there was the need to update the reference to the typical standards for Tests Nos 1 to 4 in Table 2 of Recommendation 86.

2. Engineering background for technical basis and rationale

None.

3. Source / derivation of the proposed IACS Resolution

- IMO Res. A.753(18)
- IMO Res. MSC. 313(88)
- IMO Res. MSC. 399(95)

4. Summary of Changes intended for the revised Resolution

- 1) Test No. 1 in Table 2: the text "IMO Res. A.753(18), Appendix 1, 2" has been replaced with the text "IMO Res. A.753(18), as amended, Appendix 1, 2"
- 2) Test No. 2 in Table 2: the text "UR P 4.4.2" has been replaced with the text "IMO Res. A.753(18), as amended, Appendix 3"
- 3) Tests Nos. 3 and 4 in Table 2: the text "IMO Fire Test Procedures Code" has been replaced with text "IMO Res.A.753(18), as amended, Appendix 3"

5. Points of discussions or possible discussions

None

6. Attachments if any

None

Recommendation 87 “Guidelines for Coating Maintenance & Repairs for Ballast tanks and Combined Cargo/Ballast tanks on Tankers”

Part A. Revision History

Version no.	Approval date	Implementation date when applicable
Rev.2 (May 2015)	05 May 2015	-
Rev.1 (June 2006)	20 June 2006	-
NEW (June 2004)	<i>No record</i>	-

• Rev.2 (May 2015)

.1 Origin for Change:

- Suggestion by IACS member

.2 Main Reason for Change:

IMO Res.A.744(18), which is recalled in recommendation 87(Rev.1), had been revoked by IMO Res.A.1049(27)- ESP Code.

.3 List of non-IACS Member classification societies contributing through the TC Forum and/or participating in IACS Working Group:

None.

.4 History of Decisions Made:

During the discussion under Panel task PSU14041 a Member noted that the Recommendation 87 has not been updated with the new IMO resolution A.1049(27)- ESP code.

Panel agreed that the Recommendation 87 shall be amended.

No technical background has been expected for this revision.

.5 Other Resolutions Changes

None

.6 Dates:

Original Proposal: 21 October 2014 made by IACS Member
 Survey Panel Approval: 07 February 2015 (Ref: PSU14041)
 GPG Approval: 05 May 2015 (Ref: 15022_IGd)

- **Rev.1 (June 2006)**

No records for this revision are available.

- **New (June 2004)**

No records are available.

Part B. Technical Background

Note: No Technical Background (TB) documents are available for Rec.87 New (June 2004), Rev.1 (June 2006) and Rev.2 (May 2015)



Recommendation No.88 “Periodical hydrostatic tests of air cylinders of safety equipment”

Summary

This revision is to update the reference of “MSC/Circ.850” with “MSC.1/Circ.1432”.

Part A. Revision History

Version no.	Approval date	Implementation date when applicable
Rev.1 (Apr 2020)	18 April 2020	-
New (June 2005)	June 2005	-

• Rev.1 (Apr 2020)

.1 Origin for Change:

- Other (Review of IACS instruments which have not been updated for the last ten years)

.2 Main Reason for Change:

For addressing GPG 85 FUA 9, Survey Panel reviewed the relevant Resolutions and Recommendations which have not been updated for the last ten years, and agreed to update this recommendation with the references to MSC.1/Circ.1432 which supersedes the IMO Circular MSC/Circ.850.

.3 List of non-IACS Member classification societies contributing through the TC Forum and/or participating in IACS Working Group:

None

.4 History of Decisions Made:

Survey Panel reviewed Rec. 88, and agreed to update the reference of “MSC/Circ.850” with “MSC.1/Circ.1432” which supersedes the former.

No TB is expected for this revision.

5 Other Resolutions Changes:

None

6 Any hindrance to MASS, including any other new technologies:

None

7 Dates:

Original Proposal: 29 November 2018 (Requested by GPG Vice-Chair)
Panel Approval: 6 March 2020 (Ref: PSU19016)
GPG Approval: 18 April 2020 (Ref: 19001_Ige)

- **New (July 2005)**

(No details)

Part B. Technical Background

List of Technical Background (TB) documents for Rec.88:

There is no separate technical background document available for Rec 88 New (June 2005) and Rev. 1 (Apr 2020).



Recommendation No.89 “Firms engaged in testing of navigational equipment and systems”

Summary

This revision is to delete attachment 1 and 2 due to their duplicated contents and for effective control of this recommendation.

Part A. Revision History

Version no.	Approval date	Implementation date when applicable
Rev.2 (June 2020)	18 June 2020	-
Rev.1 (Apr 2020)	18 April 2020	-
New (July 2005)	13 July 2005	-

• Rev.2 (June 2020)

.1 Origin for Change:

- Other (Further consideration after 1st Revision by a recommendation from GPG)

.2 Main Reason for Change:

During the review of 1st revision, there was a recommendation by GPG to consider streamlining attachments in Rec.89 comparing with Rec.128 due to duplicated contents and some inconsistencies between the Recommendations.

.3 List of non-IACS Member classification societies contributing through the TC Forum and/or participating in IACS Working Group:

None

.4 History of Decisions Made:

The Survey Panel reviewed Rec. 89 comparing with Rec. 128, and agreed to delete the attachment 1 and 2 due to their duplicated contents and for effective control of this recommendation.

The Survey Panel consulted with Safety Panel for the decision as recommended by GPG and the Safety Panel also agreed to the decision.

No TB is expected for this revision.

5 Other Resolutions Changes:

None

6 Any hindrance to MASS, including any other new technologies:

None

7 Dates:

Original Proposal: 18 April 2020 recommended by GPG
Panel Approval: 25 May 2020 (Ref: PSU19016)
GPG Approval: 18 June 2020 (Ref: 19001_IGi)

• **Rev.1 (Apr 2020)**

.1 Origin for Change:

Other (Review of IACS instruments which have not been updated for the last ten years)

.2 Main Reason for Change:

For addressing GPG 85 FUA 9, Survey Panel reviewed the relevant Resolutions and Recommendations which have not been updated for the last ten years, and agreed to update this recommendation with the references to the IMO Resolutions entered into force by the end of 2019.

.3 List of non-IACS Member classification societies contributing through the TC Forum and/or participating in IACS Working Group:

None

.4 History of Decisions Made:

Survey Panel reviewed Rec. 89, and agreed to update the table in item 5 and also relevant contents in the attachments 1 and 2, with the reference to relevant IMO Resolutions entered into force by the end of 2019.

No TB is expected for this revision.

5 Other Resolutions Changes:

None

6 Any hindrance to MASS, including any other new technologies:

None

7 Dates:

Original Proposal: 29 November 2018 requested by GPG Vice-Chair
Panel Approval: 06 March 2020 (PSU19016)
GPG Approval: 18 April 2020 (19001_IGe)

- **New (July 2005)**

(No details)

Part B. Technical Background

List of Technical Background (TB) documents for Rec.89:

There is no separate technical background document available for Rec 89 New (July 2005), Rev.1 (Apr 2020) and Rev.2 (June 2020).



Recommendation No. 90 "SHIP STRUCTURE ACCESS MANUAL"

Summary

In Rev.2 of this REC, updates were made to keep consistency with Rev.9 of UI SC190 and Rev.2 of UI SC191.

Part A. Revision History

Version no.	Approval date	Implementation date when applicable
Rev.2 (Nov 2024)	26 November 2024	-
Rev.1 (Apr 2019)	11 April 2019	-
Rev.0 (Oct 2005)	Oct 2005	-

• Rev.2 (Nov 2024)

1 Origin of Change:

- Based on IMO MSC Circular (Para. 1.4 of Annex to MSC.1/Circ.1572/Rev.2, which is based on Annex 5 of SDC 10/17)

2 Main Reason for Change:

During the review of UI SC190 and UI SC191 initiated after the report of IMO SDC 10 was made available in May 2024, the need for revision of this REC was identified in order to keep consistency with those UIs.

3 Surveyability review of UR and Auditability review of PR

Survey Panel checked the correctness of this revision.

4 List of non-IACS Member classification societies contributing and/or participating in IACS Working Group:

None

5 History of Decisions Made:

Survey Panel discussed this matter under PSU24024 where the need for updates to UI SC190 and UI SC191 was confirmed bearing in mind revisions made to a relevant MSC Circular (MSC.1/Circ.1572/Rev.1). These revisions of MSC.1/Circ.1572/Rev.1 were, after agreement of SDC 10, approved by MSC 108 and reflected in as MSC.1/Circ.1572/Rev.2. During the process of the revision of UI SC190 and SC191, this REC was updated accordingly to align the requirements with these UIs.

6 Other Resolutions Changes:

UI SC190, UI SC 191

7 Any hinderance to MASS, including any other new technologies:

None

8 Dates:

Original Proposal	: 31 May 2024	(Ref: PSU24024_ISUa)
Panel Approval	: 29 August 2024	(Ref: 40 th Survey Panel meeting)
GPG Approval	: 26 November 2024	(Ref: 23041mIGh)

• Rev. 1 (Apr 2019)

.1 Origin for Change:

Based on IMO Regulation (A.1049(27))

.2 Main Reason for Change:

When reviewing the IMO paper SDC 5/14/1 at the request of IACS Accredited Representative to IMO, in which it is proposed that references are still made to Resolution A. 744(18) in some IMO instruments, which should be replaced by the 2011 ESP Code as adopted by Resolution A.1049(27), Survey Panel identified several IACS Resolutions (UI SC 190, UI SC 191, REC 90 and REC 91) to be updated accordingly.

.3 List of non-IACS Member classification societies contributing through the TC Forum and/or participating in IACS Working Group:

None

.4 History of Decisions Made:

Survey Panel discussed this matter under PSU17042. Panel members agreed to amend the reference to ESP Code in Rec.91 from "resolution A.744(18), as amended" to "the ESP Code, as amended".

.5 Other Resolutions Changes

Rec.91, UI SC190, UI SC 191

.6 Any hindrance to MASS, including any other new technologies:

None

.7 Dates:

Original Proposal: 08 January 2018, made by Survey Panel
Panel Approval: 12 March 2019

GPG Approval: 11 April 2019 (Ref: 17130eIGd)

- **Rev.0 (Oct 2005)**

New recommendation Re-categorized from the provisions of SOLAS regulation II-1/3-6 adopted by resolution MSC.134(76) as amended by resolution MSC.151(78) and the Technical provisions for means of access for inspections adopted by resolution MSC.133(76) as amended by resolution MSC.158(78).

Part B. Technical Background

List of Technical Background (TB) documents for Recommendation No.90:

Note:

1) There is no separate Technical Background (TB) document for Recommendation No.90 Rev.0 (Oct 2005), Rev.1 (Apr 2019) and Rev.2 (Nov 2024).

Recommendation No. 91 “Guidelines for Approval / Acceptance of Alternative Means of Access”

Summary

To update the text, replacing “resolution A.744(18)” with “the ESP Code”.

Part A. Revision History

Version no.	Approval date	Implementation date when applicable
Rev.3 (Apr 2019)	11 April 2019	-
Rev.2 (May 2014)	08 May 2014	-
Rev.1 (Jan 2011)	11 January 2011	-
Rev.0 (Oct 2005)	07 October 2005	-

• Rev. 3 (Apr 2019)

.1 Origin for Change:

- Based on IMO Regulation (A.1049(27))

.2 Main Reason for Change:

When reviewing the IMO paper SDC 5/14/1 at the request of IACS Accredited Representative to IMO, in which it is proposed that references are still made to Resolution A. 744(18) in some IMO instruments, which should be replaced by the 2011 ESP Code as adopted by Resolution A.1049(27), Survey Panel identified several IACS Resolutions (UI SC 190, UI SC 191, REC 90 and REC 91) to be updated accordingly.

.3 List of non-IACS Member classification societies contributing through the TC Forum and/or participating in IACS Working Group:

None

.4 History of Decisions Made:

Survey Panel discussed this matter under PSU17042. Panel members agreed to amend the reference to ESP Code in Rec.91 from “resolution A.744(18), as amended” to “the ESP Code, as amended”.

.5 Other Resolutions Changes

Rec.90, UI SC190, UI SC 191

.6 Any hindrance to MASS, including any other new technologies:

None

.7 Dates:

Original Proposal: 08 January 2018, made by Survey Panel

Panel Approval: 12 March 2019

GPG Approval: 11 April 2019 (Ref: 17130eIGd)

• **Rev.2 (Mar 2014)**

.1 Origin for Change:

Suggestion by an IACS member

.2 Main Reason for Change:

One Member during the revision of the provisions of paragraph 5.6.2, relevant to the safety routines about the use of portable ladders for inspections, recognizes that this were not consistent with the provision of IACS Recommendation 78 (Safe Use of Portable Ladders for Close up Surveys). The Member proposed the modification of paragraph 5.6.2 by eliminating the figure 2 and by specifying that that the minimum raising angle (of the ladder) should be referred to the horizontal plane.

.3 List of non-IACS Member classification societies contributing through the TC Forum and/or participating in IACS Working Group:

None

.4 History of Decisions Made:

The matter was discussed by the Survey Panel at the Spring Meeting 2014 under item PSU14003.

.5 Other Resolutions Changes

None.

.6 Dates:

Original Proposal: February 2014, made by Survey Panel

Panel Approval: March 2014

GPG Approval: 08 May 2014 (Ref: 14058_IGb)

• **Rev.1 (Jan 2011)**

.1 Origin for Change:

Suggestion by an IACS member

.2 Main Reason for Change:

One member introduced a notification from shipbuilders in the Far East, related to Wire Lift Platform (WLP) and suggested Survey Panel to discuss the issue with respect to safety. One other member confirmed they had received details and approved a wire lift platform for shipboard use, accommodating one person. This would be for survey use in large tanks and cargo holds. It would be incumbent upon the surveyor, occupying the platform, to operate it, in addition to survey tasks. The purpose of the proposed change to the Recommendation is a safety concern that surveyors may not be equipped or knowledgeable to operate such machinery.

.3 List of non-IACS Member classification societies contributing through the TC Forum and/or participating in IACS Working Group:

None

.4 History of Decisions Made:

The matter was discussed at length by the Survey Panel, by correspondence and at the Spring Meeting 2010 under item PSU9022.

.5 Other Resolutions Changes

None.

.6 Dates:

Original Proposal: *August 2009, made by Survey Panel*

Panel Approval: *August 2010*

GPG Approval: *11 January 2011 (Ref: 10053_IGe)*

- **Rev.0 (Oct 2005)**

New recommendation Re-categorized from UI SC191.

Part B. Technical Background

List of Technical Background (TB) documents for Recommendation No.91:

Annex 1. **TB for Rev.1 (Jan 2011)**

See separate TB document in Annex 1.



Note:

1) There is no separate Technical Background (TB) document for Recommendation No.91 Rev.0 (Oct 2005), Rev.2 (May 2014) and Rev.3 (Apr 2019).

Technical Background for Recommendation No.91 (Rev.1, Jan 2011)

1. Scope and objectives

IACS Recommendation No. 91 'Guidelines for Approval / Acceptance of Alternative Means of Access' for compliance with SOLAS II-1/3-6 indicates various alternative (non-permanent) methods that may be used to establish access to ship's structure. The Ship Structure Access Manual prepared in accordance with SOLAS II-1/3-6 indicates permanent means of access aboard the ship and any alternative means of access that may be provided. Recommendation No. 91 contains Guidelines on these alternative means of access.

2. Engineering background for technical basis and rationale

Recommendation No. 91 Para 5.2. gives Guidelines on the use of Wire Lift Platforms. It does not, however, preclude the use of single-person operated Wire Lift Platforms, which would be operated by the surveyor for the purpose of access to survey. The Survey Panel were in broad agreement that they would not permit their staff to use these single-person operated machines, for reasons of safety. Given that the surveyor may have little or no familiarity with the given machine, which may vary between ships and indeed tanks, there is a safety concern that the surveyor may not be able to satisfactorily carry out his task while operating the wire lift platform.

3. Source/derivation of the proposed IACS Resolution

NA – the original document was produced as a result of SOLAS II-1/3-6.

4. Summary of Changes intended for the revised Resolution:

One sentence is to be added to Para 5.2 Wire Lift Platforms Para. 5.2.1 - "Such equipment should be rated for more than one person and be operated by suitably authorised personnel."

The Safety Routines Para 5.2.2 have been enhanced by the addition of four further safety considerations, referring to (a) Lift controls, safety devices and brakes (b) Load limitations (c) Working within the basket, and (d) Body belts/harnesses and lanyards.

Additionally, it was considered that the text under Para. 5.1.2 applied more generally to other types of Alternative Means of Access, and it has, accordingly, been re-sited under Para 5 with minor modification.

Furthermore, Survey Panel Task 53 – Annual Review of UI SC 191, highlighted an amendment to be made to Para 5.6.1 of Recommendation No. 91. Since this amendment is concurrent to the amendments of the same document under this Task, the amendment has been added. This is concerned with the use of portable ladders equipped with top-end securing devices for close-up survey use.

5. Points of discussions or possible discussions

The matter of surveyor-operated single-person Wire Lift Platforms was discussed at length in the Survey Panel, with many concerns being raised about the safety of surveyors operating these in addition to carrying out surveying duties.

6. Attachments if any

None

Recommendation No. 95 “Recommendation for the Application of SOLAS Regulation V/15 Bridge Design, Equipment Arrangement and Procedures (BDEAP)”

Summary

After a 10th anniversary review, references to external documents were amended and a new line for BNWAS alerts was included in table C 2.3.

Part A. Revision History

Version no.	Approval date	Implementation date when applicable
Rev.1 (Mar 2022)	28 March 2022	-
Corr.2 (July 2011)	11 July 2011	-
Corr.1 (Mar 2009)	04 March 2009	-
New (Oct 2007)	30 October 2007	-

• Rev.1 Mar 2022

1 Origin of Change:

- Other 10th anniversary review

2 Main Reason for Change:

Outdated references needed to be changed and the requirement for BNWAS alerts needed to be included.

3 List of non-IACS Member classification societies contributing or participating in IACS Working Group:

None

4 History of Decisions Made:

The Safety Panel considered each of the references to external documents included in Rec.95 and decided whether it needed to be updated. There was some discussion about the STCW Code references and which were the correct new ones. Changes were all agreed by correspondence.

5 Other Resolutions Changes:

None

6 Any hinderance to MASS, including any other new technologies:

The recommendation is for bridge design where people are present and will be applicable regardless of the extent of automation.

7 Dates:

Original Proposal : 17 November 2021 (Made by: Safety Panel Chair)
Panel Approval : 10 February 2022 (PS21015aISf)
GPG Approval : 28 March 2022 (Ref: 21197aIGb)

• Corr.2 (July 2011)

.1 Origin for Change:

- Suggestion by an IACS member

.2 Main Reason for Change:

The reference to 2.6.1, UI V/22 in paragraph B 6.5.1 in REC 095 is a reference to a paragraph in a UI that was never adopted. Therefore the reference was deleted.

.3 List of non-IACS Member classification societies contributing through the TC Forum and/or participating in IACS Working Group:

None

.4 History of Decisions Made:

The Statutory agreed with the following detailed explanation offered by DNV:

QUOTE

The reference to 2.6.1, UI V/22 in paragraph B 6.5.1 in REC 095 is a reference to a paragraph in a UI that was never adopted.

Please refer to 6023bIGa of 8 August 2006 to IACS GPG Members from IACS GPG Chairman at the time, Mr. Mo Jianhui, and the subsequent correspondence regarding the same subject.

The following is an extract from the document DraftUISOLASV22forGPGapproval300706.doc that was attached to 6023bIGa.

UNIFIED INTERPRETATIONS

IACS Unified Interpretation of requirements in SOLAS V, Regulation 22, taking into account applicable aims of regulation 15 - Submitted by the International Association of Classification Societies (IACS)

2.6.1 Sunscreens of roller blind type with minimum colour distortion, heavy duty blade type wipers,* fresh water window washing and efficient de-icing and de-misting system or other means shall be installed as required to help maintaining a clear view

through windows. A catwalk or other means shall be provided if required to help maintenance of window wipers and manual cleaning of bridge front windows.

Note:

Clear view screens, if provided, should not be installed in windows in front of the manual steering position and radars, and not more than one to each side of the centre line, available for conning.

Paragraph B 6.5.1 in REC 095 is a sheer copy of paragraph 2.6.1 in the dismissed draft UI V/22. The corrective action would simply be to delete the reference to 2.6.1, UI V/22 in paragraph B 6.5.1 in REC 095.

At present, as you are well aware, the IMO NAV CG on vague expressions in SOLAS regulation V/22 is working on issues similar to the ones addressed in the dismissed draft UI V/22. This work, though, appears to take a slightly different direction.

UNQUOTE

.5 Other Resolutions Changes

None.

.6 Dates:

Original Proposal	: April 2011	(Made by Statutory Panel)
Panel Approval	: 15 April 2011	(by Statutory Panel)
GPG Approval	: 11 July 2011	(Ref: 11108_IGb)

- **Corr.1 (Mar 2009)**

Addition of missing labels from Fig B 7.6.
GPG reference: 6023b

- **New (Oct 2007)**

Previously UI SC181 which was withdrawn.
Draft version was submitted to IMO subcommittee Nav in Spring 2007.
GPG reference: 6023b

Part B. Technical Background

List of Technical Background (TB) documents for Recommendation No.95:

Note: *There is no separate Technical Background (TB) document for New (Oct 2007), Corr.1 (Mar 2009), Corr.2 (July 2011) and Rev.1 (Mar 2022).*

Recommendation No. 96

“Double Hull Oil Tankers - Guidelines for Surveys, Assessment and Repair of Hull Structures”

Summary

In Rev.2 of this Recommendation, an update was made to maintain the consistency with the outcome of previous work related to the definition of oil tankers which was reflected in UR Z10.4(Rev.18).

Part A. Revision History

Version no.	Approval date	Implementation date when applicable
Rev.2 (May 2023)	24 May 2023	-
Rev.1 (May 2019)	30 May 2019	-
New (Apr 2007)	April 2007	-

• Rev.2 (May 2023)

1 Origin of Change:

- Suggestion by IACS member

2 Main Reason for Change:

An update of this Recommendation to maintain the consistency with UR Z10.4.

3 List of non-IACS Member classification societies contributing or participating in IACS Working Group:

None

4 History of Decisions Made:

IACS decided to update this Recommendation to maintain the consistency with the outcome of previous work related to definitions of oil tankers reflected in UR Z10.4(Rev.18).

5 Other Resolutions Changes:

UR Z11(Rev.6)

6 Any hinderance to MASS, including any other new technologies:

None

7 Dates:

Original Proposal	: 20 February 2023	(PSU23009_ISUa)
Panel Approval	: 15 March 2023	(Ref: 37th Survey Panel Meeting)
GPG Approval	: 24 May 2023	(Ref: 23079_IGb)

- **Rev.1 (May 2019)**

1 Origin of Change:

- Suggestion by IACS member

2 Main Reason for Change:

This revision is to address the policy decision made by GPG using the common terminology 'Condition of Class'(CoC) instead of the terms 'Recommendation/Condition of Class' based on the outcome of III 5.

3 List of non-IACS Member classification societies contributing through the TC Forum and/or participating in IACS Working Group:

None

4 History of Decisions Made:

During the 29th panel meeting, the panel discussed about the comments of members, and concurred with the view to retain the present definitions of CoC in the IACS resolutions with the wording 'Recommendation' to be removed. The panel also agreed to use the term 'Statutory Condition' for the 'recommendation' of the statutory certificates in IACS resolutions and RECs, and when discussing the proposal of a member to consider the harmonization of the terms of 'recommendation' and 'condition of class' in RO Code, the panel unanimously agreed to take no action on the IMO instruments, leaving the relevant actions to be decided by the relevant IMO bodies when IACS feeds back to IMO the IACS action on the harmonization of the two terms.

Panel members concurred with the view that it is not necessary to develop a new procedure requirement, and agreed to set the implementation date of these IACS resolutions (other than RECs) as 1st July 2020.

Before the implementation date of 1st July 2020 for using the common terminology 'Condition of Class' only, 'Recommendations' and 'Condition of Class' are to be read as being different terms used by Societies for the same thing, i.e. requirements to the effect that specific measures, repairs, surveys etc. are to be carried out within a specific time limit in order to retain Classification.

No TB is expected for the present revision.

5 Other Resolutions Changes:

The following IACS resolutions and Recommendations (RECs) were agreed to be revised:

- Procedural Requirements: PR1A, PR1B, PR1C, PR1D, PR1 Annex, PR3, PR12, PR20, PR35 and the attachment of PR16;
- Unified Requirements: Z7, Z7.1, Z7.2, Z10.1, Z10.2, Z10.3, Z10.4, Z10.5, Z15 and Z20
- Unified Interpretations: GC13
- Recommendations: Rec.41, Rec.75, Rec.96, Rec.98

6 Any hinderance to MASS, including any other new technologies:

None

7 Dates:

Original Proposal: 14 January 2019 Made by: GPG (17044bIGm)
Panel Approval: 3 May 2019 (PSU19010)
GPG Approval: 30 May 2019 (Ref: 17044bIGu)

• **New (Apr 2007)**

No records available.

Part B. Technical Background

List of Technical Background (TB) documents for Rec 96:

Annex 1. **TB for New (Apr 2007)**

See separate TB document in Annex 1.

Note: *There is no separate Technical Background (TB) documents available for Rev.1 (May 2019) and Rev.2 (May 2023).*

Technical Background

Recommendation 96 (NEW, April 2007)

“Double Hull Oil Tankers - Guidelines for Surveys, Assessment and Repair of Hull Structures”

Survey Panel Tasks 8 and 29

PART 1 – TB for Survey Panel Task 8

PSU Task 8: Surveyor Guidance for Assessment of Tanker Structural Conditions

1. Objective

To develop surveyor guidance addressing assessment of structural conditions on tankers including identification of defects which may contribute to serious structural failure of a vessel, such as grooving corrosion, loss of throat thickness of fillet welding, fatigue cracking, buckling, uneven corrosion of internal members, pitting in plating, etc.

2. Background

GPG 52 originally proposed this, as a result of IACS Ad-Hoc Audit AH 01 objective 3 recommendations following the casualty of the ERIKA.

This issue was part of the original Task 94 assigned to WP/SRC which GPG had subsequently added a second part for bulk carriers. WP/SRC subsequently decided to address this task in two parts. Part 2 addressing bulk carriers was completed by WP/SRC in 2004 and resulted in numerous changes being implemented for bulk carriers including the implementation of UR S31, changes to PR19, PR20, Recommendation 76 and Z10.2.

The remaining Part 1 of WP/SRC Task 94 was reassigned to the Survey Panel and was listed as Task 8.

3. Methodology of Work

The Survey Panel has progressed its work through several meetings as well as a Survey Panel Project Team consisting of ABS (Chair), BV, DNV, LR and NK. The proposed scope of work as well as the draft recommendation by the Project Team was regularly circulated to all Members for comment and agreement. Furthermore as a result of coinciding work on PSU Task 29 the Hull Panel was given an opportunity to review and comment on the draft recommendation in 2006. In addition, the Survey Panel provided an opportunity in October 2006 for the Tanker Structure Co-Operative Forum to review and comment on the draft recommendation. Unfortunately no comments were received from the TSCF.

4. Discussion

The Project Team completed a comprehensive review of information and instructions obtained from Survey Panel Members respective Society's with regards to assessment of structural conditions on tankers.

The Project Team took into consideration the current Industry Publication available:

- Guidance Manual for Inspection and Condition Assessment of Tanker Structures, 1986
- Condition Evaluation and maintenance of Tanker Structures, 1992
- Guidance Manual for Tanker Structures – Tanker Structure Co-operative Forum – Witherby 1997
- Guidelines for Ballast Tank Coating Systems and Surface Preparation – The Tanker Structure Cooperative Forum
- Guidelines for the Inspection and Maintenance of Double Hull Tanker Structures – Tanker Structure Co-operative Forum, Witherby
- Intertanko Corrosion Onboard Crude Oil Tankers – Cargo Tank Corrosion Awareness Guide Inspection, Repair and Maintenance of Ship Structures – Piero Caridis, Witherby

Project Team also took considered the following information:

- Review Japanese papers 48/3/1-3 submittal to DE with amendments to A.744(18), specifically Guidelines for major repair work of hull girders and guidelines for inspection requirements for fillet weld between deck plates and longitudinals, Guidelines on inspection requirements for fillet weld between deck plates and longitudinals and Guidelines for major repair work of hull girders.
- EMSA Report on Double Hull Tankers High Level Panel of Experts.

In the course of the work the Project Team also spent some time considering all of the changes that have already been made with regards to tankers since Task 94 (old WP/SRC Task) was first assigned to the SRC Working Party:

- Z10.1 – Intermediate surveys equivalent to previous Special Survey
- Z10.1 – Drydocking required for ESP vessels over 15 years of age
- Implementation of Z10.4
- Recommendation 87 - GUIDELINES FOR COATING MAINTENANCE & REPAIRS FOR BALLAST TANKS AND COMBINED CARGO/BALLAST TANKS ON OIL TANKERS
- Recommendation 82 Surveyor's Glossary Hull Terms & Hull Survey Terms
- Recommendation 77 Guidelines for the Surveyor on how to Control the Thickness Measurement Process
- PR 20 Procedural Requirement for certain ESP Surveys
- PR 19 Procedural Requirement for Thickness Measurements
- IMO Permanent Means of Access (PMA for new buildings)
- IMO Condition Assessment Scheme (CAS)
- Amendments to A.744 (18) which come into effect on 1 Jan 07 (parts of the CAS Survey Planning to be used for all ships)

Furthermore since this task has been under development for more than two years, several additional Tasks were assigned to the Survey Panel by GPG, which affected the development of Task 8. The additional tasks, which have been taken into account, are the following:

- Survey Panel Task 23: Revise Recommendation 54 ‘Guidelines for acceptance, application and survey of semi-hard coatings in ballast tanks’ to meet current characteristics and effective time period of the semi-hard coatings.
- Survey Panel task 29: Develop guidance for identifying significant failures caused by fatigue and the procedures to be followed when dealing with such cases.

The project team consideration the following aspects prior to proceeding:

- Apply Risk Based Approach
- Make additional changes to UR, PR, Rec to include additional text already in industry publications
- Add specific reference to industry publications in URs and/or PRs
- Since planning is key to survey, expand planning requirements
- Sum up key parts of industry and IACS members publications and issue a guidance notes
- Issue new publication for Double Hull tankers
- Is a new publication necessary for Single Hull tankers since no new designs and will eventually phase out by 2015

Three alternatives were discussed:

- A. Combined guidance
Appendix A: Double Hull Tankers
Appendix B: Single Hull tankers
- B. Separate Guidance for both Single Hull and Double Hull
- C. Issue recommendation referring to TSCF Manual on Single Hull tankers and develop new guidance on Double Hull tankers.

Project Team agreed that team should avoid getting into:

- risk based surveys.
- Leave out remote inspection techniques, as this was not part of the task.

It was agreed to go with option C and since many members already refer to the TSCF publications no specific recommendation is necessary for the repairs for the single hull tankers.

The Project Team agreed that deliverable of this task should be a recommendation on Double Hull Tankers following the same format as that contained in the IACS recommendation 76, “IACS Guidelines for Surveys, Assessment and Repair of Hull Structure - Bulk Carriers”, by using applicable portions of the TSCF books on Double hull and single tankers, IACS publications and information from Members.

It was felt that due to the phase out of single hull tankers and the fact there have been no new designs of same it was not necessary to do anything more on Single Hull tankers other than to refer to the current TSCF publication.

A new recommendation was prepared based on the above, submitted to the Hull Panel in August 2006 and submitted to the Survey Panel at the Fall 2006 and Spring 2007 meetings. Comments were addressed as applicable and incorporated into the document.

Submitted by Survey Panel Chairman
March 2007

PART 2 – TB for Survey Panel Task 29

PSU Task 29: Develop guidance for identifying significant failures caused by fatigue and the procedures to be followed when dealing with such cases

1. Objective

Develop guidance for use by Surveyors to identify significant failures caused by fatigue and the procedures to be followed when dealing with such cases.

2. Background

The request for a guidance document was initiated by the EMSA report on Double Hull Tankers by the high level panel of experts. See following references:

1. EMSA Recommendation 6 from the EMSA report on Double Hull Tankers.
2. 3125_IGh:EMSA Panel of Experts on Safety of Double Hull Tankers

3. Methodology of Work

The Survey Panel has progressed its work through several meetings as well as a combination Survey and Hull Panel Project Team consisting of ABS (Chair), GL (hull), KR, LR, NK, RINA (hull) and RS. The proposed scope of work as well as the draft recommendations by the Project Team were regularly circulated to all Members for comment and agreement. Furthermore the Hull Panel conducted a review in 2006. In addition, the Survey Panel provided an opportunity in October 2006 for the Tanker Structure Co-Operative Forum to review and comment on the draft recommendation. Unfortunately no comments were received from the TSCF.

4. Discussion

The Project Team completed a review of recommendations of the EMSA report on Double Hull Tankers in order to determine type of for development for the tasked guidance document. During this review the Project team also reviewed the draft recommendation being prepared by the Survey Panel under Project Team PSU Task 8, “Double Hull Oil Tankers, Guidelines for Surveys, Assessment and Repair of Hull Structures”.

The project team felt that with some improvements this document being prepared under Task 8 would be suitable to identify typical failures found, including fatigue analysis and assessment, pro-active repairs, recommended repair methods and means of reinforcement. In particular the following sections were of interest to this project team:

3.4.2 – Structural Defects

3.4.3 - Fatigue

3.4.3.a – Typical locations for High Sensitivity to Fatigue Failure

3.4.3.b – The effect of Higher Tensile Steel

3.4.10 – Fractures

Section 5 – Structural detail failures and repairs.

The Project Team then proceeded to amend various parts of the text under 3.4.3, 3.4.10 and some areas of text under the different groups in Section 5. The Project Team also amended numerous sketches developed some new ones.

The PT reviewed the DNV presentation, “JTP – Double hull tanker damage experience”, Sketches and Photos of hull damages for DNV built double hull oil tankers dated April 2005. From this presentation it was agreed to develop new sketches showing the deck damages associated with the DNV hull damages.

The Project team also reviewed the IACS presentation Appendix I, “Summary of Damage Records”. The Project Team noted that the IACS presentation indicated a significant amount of upper deck plating and stiffener fractures but the supporting slides did not reflect significant fractures of the deck plating. Initially it was decided to make this Appendix part of the recommendation but later the majority of the Survey Panel felt that this appendix did not contribute to the overall document.

The Project Team spent a considerable amount of time trying to deal with the work specification no. 2 and 3 related to system of formal communications between owners, operators, class societies and builders and procedures to be followed when failures are found, including fatigue analysis and assessment, pro-active repairs and recommended repair methods and means of reinforcement.

Project Team developed some guidelines under new section 5.2 of the Recommendation following similar categories identified in the EMSA report. However it was agreed that the procedure for notification and communications be covered under PR2 which at the time was being revised by an expert group.

The Project Team considered if there was a need to detail the methodology of the fatigue analysis or structural assessment however it was agreed that each individual Society will have their own comprehensive, though different, methods of assessing fatigue strength of ship structures.

The Project Team also considered whether not the guidelines should include some references to fracture mechanics and predicating crack growth but decided against this as in most cases all Societies require fractures to be repaired on trading ships.

The Project Team agreed that as this document will only be a recommendation in IACS there is no need to suggest revisions to IMO Resolution A.774(18). Considerable discussion took place on whether this should also be a requirement in a Unified Requirement or a Procedural Requirement. Work Specification items 2 and 3 indicated the scope of the this task and it would seem that based on item 3 there did not appear to be a need to go beyond a recommendation. Project Team Chairman confirmed this with the Survey Panel.

The Project Team for this task then worked very closely with the Project Team on Task 8 to finalize the recommendation. It was submitted to the Hull Panel in August 2006 and submitted to the Survey Panel at the Fall 2006 and Spring 2007 meetings. Comments were addressed as applicable and incorporated into the document.

Submitted by Survey Panel Chairman
March 2007

PART 3 – Permanent Secretariat note (June 2007)

New Recommendation 96 was approved 28 April 2007 (ref. 7549_IGb).

Recommendation No.98

“Duties of Surveyors under Statutory Conventions and Codes”

Summary

1. This revision is to harmonize the terms of ‘recommendation’ and ‘condition of class’ with only the term ‘condition of class’ being retained.
2. Additionally, to align the annex A of Rec. 98 with the IMO Resolution A.1119(30). Two (2) items are revised and three (3) items are added accordingly.

Part A. Revision History

Version no.	Approval date	Implementation date when applicable
Rev.3 (June 2019)	08 June 2019	-
Rev.2 (June 2016)	28 June 2016	-
Rev.1 (Mar 2012)	06 March 2012	-
New (Sept 2007)	11 September 2007	-

• Rev.3 (Jun 2019)

.1 Origin of Change:

- Suggestion by an IACS Member

.2 Main Reason for Change:

.2.1 This revision is to address the policy decision made by GPG using the common terminology ‘Condition of Class’(CoC) instead of the terms ‘Recommendation/ Condition of Class’ based on the outcome of III 5.

.2.2 Additionally, to align the annex A of Rec. 98 with the IMO Resolution A.1119(30).

.3 List of non-IACS Member Classification Societies contributing through the TC Forum and/or participating in IACS Working Group:

None

.4 History of Decisions Made:

.4.1 Harmonization of the terms ‘recommendation’ and ‘condition of class’ (PSU19010)

During the 29th panel meeting, the panel discussed about the comments of members, and concurred with the view to retain the present definitions of CoC in the IACS resolutions with the wording 'Recommendation' to be removed. The panel also agreed to use the term 'Statutory Condition' for the 'recommendation' of the statutory certificates in IACS resolutions and RECs, and when discussing the proposal of a member to consider the harmonization of the terms of 'recommendation' and 'condition of class' in RO Code, the panel unanimously agreed to take no action on the IMO instruments, leaving the relevant actions to be decided by the relevant IMO bodies when IACS feeds back to IMO the IACS action on the harmonization of the two terms.

Panel members concurred with the view that it is not necessary to develop a new procedure requirement, and agreed to set the implementation date of these IACS resolutions (other than RECs) as 1st July 2020.

Before the implementation date of 1st July 2020 for using the common terminology 'Condition of Class' only, 'Recommendations' and 'Condition of Class' are to be read as being different terms used by Societies for the same thing, i.e. requirements to the effect that specific measures, repairs, surveys etc. are to be carried out within a specific time limit in order to retain Classification.

.4.2 Amendment to Annex A: (PSU18026)

Following the publication of the IMO Resolution A.1119(30), Procedures for port state control, 2017, Panel reviewed, under task PSU 18026, the text of the Rec. 98 with a view to aligning the corresponding items with Appendix 2 of the IMO Resolution.

Survey Panel members agreed to align item 10 under "SOLAS Convention" and item 3 under "MARPOL 73/78/97, Annex VI" of the Rec. 98 with the text of item 10 under "Areas under the SOLAS Convention" and item 3 under "Areas under the MARPOL Convention, Annex VI" of the IMO Resolution A.1119(30) respectively.

Survey Panel members further discussed detainable deficiencies to be indicated in Rec. 98 to assist surveyors and agreed to add items 14 and 15 under "SOLAS Convention" and item 5 under "Chemical Codes" in the revised Rec. 98 in accordance with items 15 and 16 under "Areas under the SOLAS Convention" and item 8 under "Areas under the IBC Code" of the IMO Resolution A.1119(30) respectively.

Panel during the 29th meeting discussed and agreed with the revised Rec. 98.

The reference to A.1104(29) was agreed to updated with A.1120(30).

After consulting with IACS Safety Panel, Survey Panel discussed their comments as follows:

- Survey panel concurred with the comment of Safety Panel to remove the wording "or 'certificate'" from paragraph 2.1;
- Survey Panel concurred with the view of Safety Panel that the terminologies "non-periodical survey" and "port state control survey" used in paragraphs 5.1 and 5.3.1 are not in accordance with the surveys provided in various IMO Conventions and Codes, and agreed to make a reference to the paragraph 2.8.7 of HSSC Survey Guidelines (A.1120(30)) and use "additional survey" and "additional survey for port state control" in lieu of the two terminologies.

No TB is expected for the present revision.

.5 Other Resolutions Changes

The following IACS resolutions and Recommendations (RECs) were agreed to be revised:

- Procedural Requirements: PR1A, PR1B, PR1C, PR1D, PR1 Annex, PR3, PR12, PR20, PR35 and the attachment of PR16;
- Unified Requirements: Z7, Z7.1, Z7.2, Z10.1, Z10.2, Z10.3, Z10.4, Z10.5, Z15 and Z20
- Unified Interpretations: GC13
- Recommendations: Rec.41, Rec.75, Rec.96, Rec.98

.6 Any hinderance to MASS, including any other new technologies:

None.

.7 Dates:

Original Proposal: 14 January 2019 tasked by GPG (17044bIGm)
May 2018, Made by a Survey Panel Member (PSU18026)
Panel Approval: 22 March 2019 (PSU19010)
26 May 2019 (PSU18026)
GPG Approval: 8 June 2019 (Ref: 17044bIGx)

• Rev.2 (June 2016)

.1 Origin of Change:

- Other (GPG suggestion)

.2 Main Reason for Change:

To adjust the procedures in Rec. 98 to be in accordance with the IMO Resolution A.1104(29).

.3 List of non-IACS Member Classification Societies contributing through the TC Forum and/or participating in IACS Working Group:

None

.4 History of Decisions Made:

Following the issue of the IMO Resolution A 1104(29), Survey Guidelines under the Harmonized System of Survey and Certification (HSSC) 2015, and the revision of the Procedural Requirements PR12 (rev.2) and PR 28(Rev.1) Panel reviewed, under task PSU 14009, the text of the Rec. 98 with the view to harmonize the terminology with that used by the IMO Resolution itself.

During the correspondence rounds Members agreed to replace the definition of findings with the wording deficiency/defects according to those adopted in paragraph 4.8.3.1 and paragraph 4.7 of the IMO Resolution A.1104(29).

In addition, it has been modified the definition of the Statutory Condition and condition of Class in order to align them with the wording used in paragraph 4.8.3 of the IMO Resolution A.1104(29) and the definition of condition of class adopted in PR 35.

The paragraphs 5.2.1, 5.2.2 and 5.4 has been aligned to the text of paragraph 4.8.3.1 of the IMO Resolution A.1104(29).

Panel during the 23rd meeting discussed and approved unanimously all the modification.

For the present revision no technical background has been expected.

.5 Other Resolutions Changes:

None

.6 Dates:

Original Proposal: November 2015, Made by: GPG
Panel Approval: 04 April 2015 (Ref: PSU14009)
GPG Approval: 28 June 2016 (Ref: 14201_IGI)

• Rev.1 (Mar 2012)

.1 Origin of Change:

Suggestion by IACS member

.2 Main Reason for Change:

To adjust the procedures in Rec. 98 to be in accordance with today's implemented practice among class societies.

.3 List of non-IACS Member Classification Societies contributing through the TC Forum and/or participating in IACS Working Group:

None

.4 History of Decisions Made:

A member raised a matter of unreasonable aspect in issuing a condition of class instead of withdrawing the applicable statutory certificate and issuing a short term certificate when the surveyor find the ship cannot be repaired during the survey. Although EMSA gave a non-compliance to this practice quoting IMO A. 997(25), there still seems to remain ambiguity applying the relevant requirements to reality due to large overlap of class and statutory. Various opinions including introduction of each IACS member societies' practice have been exchanged within the Survey panel and

trial to reinforce the relevant IACS resolution was carried out

.5 Other Resolutions Changes:

None

.6 Dates:

Original Proposal: August 2010, Made by: Survey Panel
Panel Approval: December 2011
GPG Approval: 06 March 2012 (Ref: 10004_IGe)

- **New (Sept 2007)**

Previously IG 3 (Rev.4 July 2006).

Changes to text at 1.3, 5.4 and the Reference note for re-categorisation.

GPG reference: 7543

Part B. Technical Background

List of Technical Background (TB) documents for Rec. 98:

Note:

1) There are no separate Technical Background (TB) documents for Recommendation No.98 New (Sept 2007), Rev.1 (Mar 2012), Rev.2 (Jun 2016) and Rev.3 (Jun 2019).

Recommendation No.99 “Recommendations for the Safety of Cargo Vessels of less than Convention Size”

Part A. Revision History

Version no.	Approval date	Implementation date when applicable
Rev.1 (Apr 2013)	18 April 2013	-
NEW (Dec 2007)	14 December 2007	-

- **Rev.1 (Apr 2013)**

.1 Origin for Change:

- Suggestion by IACS member

.2 Main Reason for Change:

Entry into force of the INTERNATIONAL CODE ON INTACT STABILITY, 2008 (2008 IS CODE), IMO RES. Msc.267(85).

Chapter III of Rec.99 was amended to bring it in line with UR L2 (Rev.2) and to clarify the applicability to ships having a length of less than 24m.

.3 List of non-IACS Member classification societies contributing through the TC Forum and/or participating in IACS Working Group:

None

.4 History of Decisions Made:

The Form A was approved by the GPG on 9 November 2011.

.5 Other Resolutions Changes

IACS UR L2 (Intact stability – matter of class)

.6 Dates:

Original proposal: *10 October 2011 Made by: Statutory panel*

Panel Approval: *14 March 2013 (Statutory panel)*

GPG Approval: *18 April 2013 (Ref. 11160_IGf)*

- **NEW (Dec 2007)**

New recommendation was developed as a result of re-categorisation of IACS Internal Guidelines 2 (Deleted in Dec 2007) (Ref: SP6011_PCI & 5142c).

No TB document available.

Part B. Technical Background

List of Technical Background (TB) documents for Recommendation 99:



Note: There are no Technical Background (TB) documents available for IACS Recommendation 99 New (Dec 2007) and Rev.1 (Apr 2013).

Technical Background

Rec. 100 (NEW, February 2008)

IACS recommended practice on the time requirement for thoroughly closing sea inlets and discharges below the waterline in case of influx of water

The Statutory Panel received an enquiry from the Finnish Maritime Administration who intends to seek IACS common practice for compliance with International Convention on Load Lines, 1966 Regulation 22 (3) in the amended protocol, MSC.143(77) and SOLAS II-1/48.3. FMA demonstrated its interpretation to this regulation, i.e. require 30 minutes for fulfilling this regulation.

The Statutory Panel initiated a discussion on this matter for achieving a common view in application of the regulation.

The panel reached a consensus that FMA mixed the requirement set out in ILLC 66 Reg. 22.3 (MSC.143(77)) and in SOLAS Reg. II-1/48.3.

The members of the panel rendered their practices in application of the regulation, which revealed that a common position can not be reached by the panel on this matter. As a result, the panel decided to develop a Recommendation rather than a UI, and forward this recommendation to FMA by means of a cover letter.

This Recommendation was developed to address the issue related to the application of both ICLL 66 Reg. 22(3) (MSC.143(77)) and SOLAS Reg. 48.3 in order to prepare an IACS recommended practice for applying the requirements set forth in the IMO Instruments above regarding the time requirement for thoroughly closing sea inlets and discharges below the waterline in case of influx of water.

The panel considered that it isn't practicable to request a fixed amount of time for the influx of water to reach the control as it is dependant on the ship size and the size and layout of the machinery space.

The panel therefore recommends that a calculation should be carried out to show that the time taken from alarm activation plus the time* to reach and fully close manually operated or powered valves, is less than the time taken for the influx of water to reach the control without submergence of the platform on which the person is operating the valve.

To achieve similar results of the same ship calculated by all Members, a note regarding the calculation of "the time" is agreed and added with reference to MSC/Circ.1033 and MSC.245(83) as follows:

(* The time it will take to reach and close the sea valves should be determined by multiplying the inverse of the nominal speed of travel of a person onboard (1.0 m/sec based on the values taken from MSC/Circ.1033) times the distance to be traveled from the platform in way of manually operated valves (or the actuator for valves controlled by stored mechanical energy) to either:

- (i) the highest position of the control room for an ER under continuous manned supervision; or
- (ii) from the navigation bridge for an unmanned ER.

The time it takes for the influx of water into the ER should be determined based on the fluid dynamic principles contained in MSC.245(83) applied to a breach in the largest diameter seawater line in the lowest and highest locations in the ER and the valve associated with that seawater line.)

In the event calculations are not available, 10 minutes shall be regarded as adequate time for operation unless other requirements are specified by the flag Administration.

Submitted by Statutory Panel Chairman
13 March 2008

Permanent Secretariat note (April 2008):

New IACS Rec.100 was approved by GPG on 26 February 2008 (ref. 8517_IGc).

Rec 103 Guidance for the compilation of the IOPP Supplement

Summary

The Rev.1 of Rec.103 is updated to reflect Resolution MEPC.276 (70), i.e. Amendments to MARPOL Annex I - Form B of the Supplement to the International Oil Pollution Prevention Certificate

Part A. Revision History

Version no.	Approval date	Implementation date when applicable
Rev.1 (July 2020)	07 July 2020	-
New (Dec 2008)	17 December 2008	-

• Rev.1 (July 2020)

1 Origin of Change:

- Suggestion by IACS member
- Based on IMO Regulation (Resolution MEPC.276 (70), Amendments to MARPOL Annex I - Form B of the Supplement to the International Oil Pollution Prevention Certificate)

2 Main Reason for Change:

To update the Rec. 103 to reflect Resolution MEPC.276 (70), i.e. Amendments to MARPOL Annex I (Form B of the Supplement to the International Oil Pollution Prevention Certificate)

3 List of non-IACS Member classification societies contributing or participating in IACS Working Group:

None

4 History of Decisions Made:

Environmental Panel has conducted a review of all IACS Resolutions responsible to the panel. It is noted that para. 5.8 in Form B of the Supplement to IOPPC has been renumbered to para. 5.6 as para. 5.3 and 5.5 were deleted as per Resolution MEPC.276 (70). The panel agreed that Rec. 103 should be modified accordingly.

5 Other Resolutions Changes:

None

6 Any hinderance to MASS, including any other new technologies:

None

7 Dates:

Panel Approval: 02 October 2019 (Ref: PE19019a)

GPG Approval: 07 July 2020 (Ref: 19273_IGe)

- **New (Dec 2008)**

No records available.

Part B. Technical Background

List of Technical Background (TB) documents of Rec.103:

Annex 1. **TB for New (Dec 2008)**

See separate TB document in Annex 1.



Note: There is no separate Technical Background (TB) document available for Rec. 103 (Rev.1, July 2020)

Technical Background

Recommendation No.103 (New, Dec 2008)

Preamble: IACS Internal Guideline No.13 (April 2006) provided guidance to surveyors for the compilation of the IOPP Supplement. Following GPG 62 (March 2007) it was decided to update the document and re-categorize it as a recommendation.

1. The Statutory Panel tasked the Project Team SP7005k (PT) with revising IG 13 based on the comments provided by the Statutory Panel (SP) members. For more detail see the section 'Development History' below.
2. In an effort to standardize the completion of section 5.8 of the supplement form B to the International Oil Pollution Prevention Certificate "Double-hull construction", and to ensure that the different categories of oil tankers described in the regulations of MARPOL Annex I are clearly identified in section 5.8, a document was submitted to IMO Marine Environment Protection Committee 58th session (MEPC 58/6/4) proposing amendments to the section in question.
3. Upon review of the regulations contained in MARPOL Annex I, revisions were proposed to identify the following categories of oil tankers in section 5.8:
 - (a) tankers in compliance with MARPOL Annex I Regulation 19.6,
 - (b) tankers not subject to a phase out date based on size,
 - (c) existing tankers not subject to a phase out date because of compliance with double hull requirements as specified in MARPOL I/19,
 - (d) tankers not subject to a phase out date based on the alternative protection distances specified in MARPOL I/20.1.3 and I/21.1.2.
 - (e) tankers between 600 and 5000 deadweight tons which comply with double hull arrangements in accordance with MARPOL I/21.4.2.
 - (f) tankers not carrying heavy grade oil (HGO).

During MEPC58, the proposed revisions were approved by the Committee and published as an annex to the meeting report (MEPC 58/23 Annex 19).

4. Recognizing that IACS cannot implement such changes before such revisions to a mandatory instrument enter into force, IACS released the Recommendation which, although it does not accomplish the precision of the proposed amendments mentioned above, it does provide some clarification as to the completion of the Form B. This Recommendation will be withdrawn upon entry into force of the above mentioned amendments.

Development History:

1. The PT reviewed 12 messages from the SP members and identified 13 proposals to revise the IG 13 draft version attached to message SP7005kPCd. The list of messages from the SP members and the proposals have been summarized in Annex 1 "SP7005k PT Proposals Summary". The Summary includes the agreement or disagreement to the proposals by the PT members

and whether the proposal was incorporated to the IG 13 draft version selected as starting point. From the 13 proposals identified in the messages, the PT agreed to incorporate 10 proposals into the IG 13 draft version. We proceed to describe the reasoning to incorporate the 10 proposals:

(a) SP Comment 1: MARPOL I/19.2 describes that regulations in column 2 item 5.8.1 are applicable to oil tankers of 5000 DWT and above.

(b) SP Comment 2: It is consider a redundancy to label oil tankers in column 2 as "R19 Oil Tankers" when the tankers are required to comply with MARPOL I/19 because of their date of construction as defined in 1.28.6.

(c) SP Comment 4: It is consider necessary to maintain the label in column 3 "R19 Oil Tankers" to identify oil tankers that comply with MARPOL I/19, but are not required to.

(d) SP Comment 5: Column 3 item 5.8.4 to be marked with a dash "-" as the vessel complies with MARPOL I/19 and a phase out date is not applicable.

(e) SP Comment 6: Column 3 item 5.8.5 to be marked with a "X" as the vessel complies with MARPOL I/19.

(f) SP Comment 7: Column 3 item 5.8.6 to be marked with a dash "-" as the vessel complies with MARPOL I/19 and a phase out date is not applicable.

(g) SP Comment 8: Column 3 item 5.8.7 to be marked with a "X" as the vessel complies with MARPOL I/19 and not subject to MARPOL I/21.

(h) SP Comment 9: Column 6: It is consider a redundancy to label oil tankers in column 6 "R19 Oil Tankers" as the heading of the column specifies compliance with MARPOL I/19 already, because of their date of construction.

(i) SP Comment 10: It is consider a redundancy to label oil tankers in columns 8 to 10 "R19 Oil Tankers", as the sub-columns headings and footnote specify the exact type of hull construction.

(j) SP Comment 11: Footnote 1 was re-written to clarify the footnote.

2. For the messages from the SP members, the summary table was marked with a "C" to identify the message where the proposal was extracted from, an "A" to identify the message that agreed with the proposal and "✓" (a check) to identify the proposals that were incorporated into the IG 13 draft.
3. Additionally, the PT generated 6 proposals. The team agreed to incorporate 4 proposals into the IG 13 draft. The summary of these proposals is also in the attached file "SP7005k PT Proposals Summary". The team proposals have been identified with a "TP" before the number.
4. With regard to the 4 PT proposals incorporated into the IG 13 draft, please consider the following comments:

(a) TP3: We consider this an editorial revision.

(b) TP4: A sentence was added to clarify when footnote 1 is applicable.

(c) TP5: Footnote 2 "to be annotated with X if the ship complies" was deleted considering that the heading for the four columns to which the footnote was assigned indicate that the oil tankers comply with MARPOL I/19, even though compliance is not required. Therefore, it is the PT understanding that the phrase "if the ship complies" is redundant for oil tankers which voluntarily comply.

(d) TP6: It was noted that the current IG 13 draft version recommends to

complete section 5.8 (same items are "X") in the same manner for (i) oil tankers meeting double bottom requirements not carrying HGO, and (ii) oil tankers meeting the double hull requirements of MARPOL I/21.4.2. Furthermore it was noted that the supplement form B does not have provisions to identify oil tankers in compliance with MARPOL I/21.4.2. As it would not be possible to amend the supplement form B before the IACS Recommendation is published, the PT agreed to incorporate TP6 to make a distinction between oil tankers listed in (i) and (ii) above when section 5.8 of form B is completed.

Submitted by Statutory Panel Chairman
1 December 2008

Permanent Secretariat note (January 2009):

New Recommendation No.103 was approved by GPG on 17 December 2008 (ref. 7543alGf).

**ANNEX 1 - Technical Background
PT SP7005k - Recategorization of IG 13 to
Recommendation
Rev. date: 5 June 2008**

COMMENTS	MESSAGE												PT Members Agreement (Y/N)		
	ABS SP7005kABe	BV* SP7005kPCe	CCS SP7005kCCd	DNV SP7005kNVc	GL SP7005kGLc	IRS SP7005kIRb	KR SP7005kKRd	LRS SP7005kLRc	NK SP7005kNKc	RINA SP7005kRId	RS SP7005kRSd	ABS SP7005kABf	ABS	KR	RS

Agreement with draft as per SP7005kPCd, i.e. no comments	-	-	-	-	A	-	A	-	-	A	-	-	-	-	-
(1) ✓ Column 2 – Heading: The header for the column shall indicate greater than 5000 DWT, i.e. (DWT ≥ 5000 t)	C	A	A	A	-	A	-	A	A	-	A	-	Y	Y	Y
(2) ✓ Column 2 – Heading: Delete “R19” before “Oil Tankers”	-	-	-	-	-	-	-	-	C	-	-	A	Y	Y	Y
(3) Column 3 – Heading: Delete “R19” before “Oil Tankers”	-	-	-	-	-	-	-	-	C	-	-	-	N	N	N
(4) ✓ Column 3 – Heading: Maintain “R19” before “Oil Tankers”	-	-	-	-	-	-	-	-	-	-	-	C	Y	Y	Y
(5) ✓ Column 3 - Item 5.8.4: Item to be marked with a “-” as the vessel is DH and not subject to MARPOL I/20.	C	A	A	A	-	A	-	A	-	-	-	-	Y	Y	Y
(6) ✓ Column 3 – Item 5.8.5: Item to be marked with an “X” as the vessel is DH and not subject to MARPOL I/20.	C	A	A	A	-	A	-	A	-	-	-	-	Y	Y	Y
(7) ✓ Column 3 – Item 5.8.6: Item to be marked with a “-” as the vessel is DH and not subject to MARPOL I/21.	C	A	A	A	-	A	-	A	-	-	-	-	Y	Y	Y
(8) ✓ Column 3 – Item 5.8.7: Item to be marked with an “X” as the vessel is DH and not subject to MARPOL I/21.	C	A	A	A	-	A	-	A	-	-	-	-	Y	Y	Y
(9) ✓ Column 6 – Heading Delete “R19” before “Oil Tankers”	-	-	-	-	-	-	-	-	C	-	-	A	Y	Y	Y
(10) ✓ Columns 8 to 10 – Heading Delete “R19” before “Oil Tankers”	-	-	-	-	-	-	-	-	C	-	-	A	Y	Y	Y

- C → Comment in the message to revise the matrix
A → Agreement with the comment
✓ → Comment incorporated in the draft from message SP7005kPCd

**ANNEX 1 - Technical Background
PT SP7005k - Recategorization of IG 13 to
Recommendation
Rev. date: 5 June 2008**

													PT Members Agreement (Y/N)		
MESSAGE															
COMMENTS	ABS SP7005kABe	BV* SP7005kPCe	CCS SP7005kCCd	DNV SP7005kNVc	GL SP7005kGLc	IRS SP7005kIRb	KR SP7005kKRd	LRS SP7005kLRc	NK SP7005kNKc	RINA SP7005kRId	RS SP7005kRSd	ABS SP7005kABf	ABS	KR	RS

(11) ✓ Footnote (1): For clarity the following text should replace the current text: “The appropriate sub-item(s) under 5.8.6 is(are) to be annotated with “X” if tanker carries HGO. If the tanker does not carry HGO, item 5.8.7 is to be annotated with “X”.”	C	A	A	-	-	A	-	A	-	-	-	-	Y	Y	Y
(12) Footnote (1): Delete the footnote based on the proposal to add a proviso to the International Oil Pollution Prevention Certificate to indicate that the ship is prohibited from carrying HGO. Then, only item 5.8.6 should be marked.	-	-	-	C	-	-	-	-	-	-	-	-	N	N	N
(13) Footnote (2): Delete the footnote based on the proposal to amend items 5.8.5 and 5.8.7 of Form B to explicitly describe the reasons the oil tankers are not subject to MARPOL I/20 and/or 21. The reasons included are: (i) compliance with MARPOL I/19 (Ref. MARPOL I/21.1.2, 20.4.1 or 20.4.2) (ii) DWT of the oil tanker (iii) compliance with MARPOL I/20.1.3 or 21.1.2 (IBC Code distances)	-	-	-	C	-	-	-	-	-	-	-	-	N	N	N

- C → Comment in the message to revise the matrix
- A → Agreement with the comment
- ✓ → Comment incorporated in the draft from message SP7005kPCd

**ANNEX 1 - Technical Background
PT SP7005k - Recategorization of IG 13 to
Recommendation
Rev. date: 5 June 2008**

COMMENTS	MESSAGE												PT Members Agreement (Y/N)		
	ABS SP7005kABe	BV* SP7005kPCe	CCS SP7005kCCd	DNV SP7005kNVc	GL SP7005kGLc	IRS SP7005kIRb	KR SP7005kKRd	LRS SP7005kLRc	NK SP7005kNKc	RINA SP7005kRId	RS SP7005kRSd	ABS SP7005kABf	ABS	KR	RS

(TP1) Comment from SP7005kPTRSc Column 1, item 5.8.2 – “(double bottom requirements) shall be added as indicated in Form B.”	-	-	-	-	-	-	-	-	-	-	-	-	N	N	N
(TP2) Comment from SP7005kPTRSc Column 5 Heading – the heading should be replaced by “Oil Tankers <R19 Date (DWT≥5000 t)”.	-	-	-	-	-	-	-	-	-	-	-	-	N	N	N
(TP3) ✓ Comment from SP7005kPTABa (original 15a) Column 7 Heading - replace "complies" with "in compliance"	-	-	-	-	-	-	-	-	-	-	-	-	Y	Y	Y
(TP4) ✓ Comment from SP7005kPTABa (original 15b) Addition after the first sentence in footnote (3): “Footnote (1) is applicable when item 5.8.2 is “X”.”	-	-	-	-	-	-	-	-	-	-	-	-	Y	Y	Y
(TP5) ✓ Comment from SP7005kPTABa (original 12) Footnote 2 – Delete the footnote based on the understanding that the column headings indicate that the vessels comply with Reg. 19. Accordingly, the footnote can be deleted and an “X” is required in all four cases in the matrix: ✓ (a) Column 3 item 5.8.1 ✓ (b) Column 6 item 5.8.1 ✓ (c) Column 9 item 5.8.2 ✓ (d) Column 10 item 5.8.2	-	-	-	-	-	-	-	-	-	-	-	-	Y	Y	Y
(TP6) ✓ Comment from SP7005kPTMNg Footnote 4 – Add footnote “(4) Item 5.8.2 is to be annotated with the proviso: “(Complies with double hull requirements as per 21.4.2)”.	-	-	-	-	-	-	-	-	-	-	-	-	Y	Y	Y

- C → Comment in the message to revise the matrix
A → Agreement with the comment
✓ → Comment incorporated in the draft from message SP7005kPCd

TECHNICAL BACKGROUND

Recommendation 104 (New, March 2009) *“Qualification scheme for welders of steels”*

1. Scope and objective

To develop a new requirement for qualification scheme for welders who are engaged in welding works of hull structural steels in a shipyard or a manufacturer.

2. Background

No current IACS document exists with regard to welder qualification, today any construction requires that welder qualification tests are necessary and should be monitored. The IACS WP/MW recognised this and also noted that current guidance given to shipyards by individual classification societies often resulted in conflict between shipyards and classification society due to the varying requirements of individual societies. Therefore WP/WM raised the Form A but the work was not initiated until reorganisation of the old IACS working groups occurred. The work item was taken over by Hull Panel as their Task 24 and allocated to Project Team 2.

3. Points of discussions

The project team found common ground on the procedures to be followed.

It was unanimously agreed that the document should be developed as a recommendation to give time for experience of the use of the document before consideration of upgrading the document to a UR in the future.

At a very early stage it was also recognized that a single document to cover qualification of both steel and aluminium alloys was not practical and therefore two separate documents were produced.

A review was carried out between the societies to compare actual requirements against actual ship yard practice around the world, there were some obvious differences and a balanced approach was taken to satisfy the requirements appropriate to each society.

A number of points were raised by the Hull Panel on the first draft submitted. These were reviewed by PT2 and where appropriate amendments made or reasons for rejecting the suggestions given.

4. Recommendation.

The Hull Panel and its PT2 recommends the adoption of the document “Qualification scheme for welders of steels” as Recommendation 104.

5. Source/Derivation of proposed interpretation

N.A.

6. Decision by voting

The draft had full agreement of the Hull Panel and PT2.

Submitted by Hull Panel Chairman
27 January 2009

Permanent Secretariat note (March 2009):

GPG approved new Rec 104 on 6 March 2009 (ref. 9520_IGc).

During GPG discussion the following comments were made by members:

- 1) It was suggested that 6G (pipe) position should be included in Rec 104 as test acceptable for qualifying welder's for plate welding. Three members disagreed with this suggestion mentioning that the proposed draft is about plate welding only.
- 2) It was suggested that GPG should task Hull Panel to review the possibility or need to include contents about pipe welding and '6G' in the subjected draft recommendations (104 and 105) before the approval of GPG. Two members disagreed with this suggestion mentioning that they do not see the compelling need. One member added that this suggestion can be done later if and when it is considered the Recs should become URs.
- 3) One member raised the issue of inconsistencies between the new Recs 104 and 105 and ISO standards. However noting that the recommendations do not have a compulsory nature like URs, GPG Chair proposed that these inconsistencies were not a compelling reason to amend the Recs and proposed to revisit this issue at a later date if and when it is considered that the Recs should become URs. No members disagreed with this proposal.

Rec 105 “Qualification scheme for welders of aluminium alloys”

Summary

In Corr.1 of this Recommendation, editorial errors have been corrected.

Part A. Revision History

Version no.	Approval date	Implementation date when applicable
Corr.1 (Jan 2022)	12 January 2022	-
Rev.1 (Sep 2021)	21 September 2021	-
New (Mar 2009)	March 2009	-

• Corr.1 (Jan 2022)

1 Origin of Change:

- Suggestion by non-IACS Classification Society

2 Main Reason for Change:

There was a need to replace the reference to IACS Recommendation 104 by reference to IACS UR W32.

3 List of non-IACS Member classification societies contributing or participating in IACS Working Group:

None.

4 History of Decisions Made:

None.

5 Other Resolutions Changes:

None.

6 Any hinderance to MASS, including any other new technologies:

None.

7 Dates:

Original Proposal	: 18 November 2021	(Made by Türk Loydu)
EG M&W Approval	: 18 December 2021	(Ref: 19000_EMWd)
GPG Approval	: 12 January 2022	(Ref: 19000_IGs)

- **Rev.1 (Sep 2021)**

1 Origin of Change:

Suggestion by IACS member

2 Main Reason for Change:

To update industry standards format according to GPG instructions given in GPG Vice-chair message 19000_IRC.

3 List of non-IACS Member classification societies contributing through the TC Forum and/or participating in IACS Working Group:

None.

4 History of Decisions Made:

Original proposal was made according to GPG Vice-chair message 19000_IRc. Proposal to revise the IACS URs and RECs only to refer to a dated version of the industry standard as per GPG instructions was made at IACS EG/MW meeting in September 2019. Three drafts have been discussed by the group.

5 Other Resolutions Changes:

None.

6 Any hinderance to MASS, including any other new technologies:

None.

7 Dates:

Original Proposal	: April 2019	(Made by GPG)
EG M&W Approval	: July 2021	
GPG Approval	: 21 September 2021	(Ref: 19000_IGq)

- **New (March 2009)**

Refer to Part B, Annex 1 for TB file.

Part B. Technical Background

List of Technical Background (TB) documents for Rec 105:

Annex 1. **TB for New (Mar 2009)**

See separate TB document in Annex 1.

Annex 2. **TB for Rev.1 (Sep 2021)**

See separate TB document in Annex 2.

Annex 3. **TB for Corr.1 (Jan 2022)**

See separate TB document in Annex 3

TECHNICAL BACKGROUND

Recommendation 105 (New, March 2009) *“Qualification scheme for welders of aluminium alloys”*

1. Scope and objective

To develop a new requirement for qualification scheme for welders who are engaged in welding works of aluminium alloys for hull structures in a shipyard or by a manufacturer.

2. Background

No current IACS document exists with regard to welder qualification, today any construction requires that welder qualification tests are necessary and should be monitored. The IACS WP/MW recognised this and also noted that current guidance given to shipyards by individual classification societies often resulted in conflict between shipyards and classification society due to the varying requirements of individual societies. Therefore WP/WM raised the Form A but the work was not initiated before reorganisation of the old IACS working groups occurred. The work item was taken over by Hull Panel as their Task 24 and allocated to Project Team 2.

3. Points of discussions

The project team found common ground on the procedures to be followed.

It was unanimously agreed that the document should be developed as a recommendation to give time for experience of the use of the document before consideration of upgrading the document to a UR in the future.

At a very early stage it was also recognized that a single document to cover qualification of both steel and aluminium alloys was not practical and therefore two separate documents were produced.

A review was carried out between the societies to compare actual requirements against actual ship yard practice around the world, there were some obvious differences and a balanced approach was taken to satisfy the requirements appropriate to each society.

A number of points were raised by the Hull Panel on the first draft submitted. These were reviewed by PT2 and where appropriate amendments made or reasons for rejecting the suggestions given.

4. Recommendation.

The Hull Panel and its PT2 recommends the adoption of the document “Qualification scheme for welders of aluminium alloys” as Recommendation 105.

5. Source/Derivation of proposed interpretation

N.A.

6. Decision by voting

The draft had full agreement of the Hull Panel and PT2.

Submitted by Hull Panel Chairman
27 January 2009

Permanent Secretariat note (March 2009):

GPG approved new Rec 105 on 6 March 2009 (ref. 9520_IGc).

During GPG discussion the following comments were made by members:

- 1) It was suggested that GPG should task Hull Panel to review the possibility or need to include contents about pipe welding and '6G' in the subjected draft recommendations (104 and 105) before the approval of GPG. Two members disagreed with this suggestion mentioning that they do not see the compelling need. One member added that this suggestion can be done later if and when it is considered the Recs should become URs.
- 2) One member raised the issue of inconsistencies between the new Recs 104 and 105 and ISO standards. However noting that the recommendations do not have a compulsory nature like URs, GPG Chair proposed that these inconsistencies were not a compelling reason to amend the Recs and proposed to revisit this issue at a later date if and when it is considered that the Recs should become URs. No members disagreed with this proposal.

Technical Background (TB) document for Rec 105 Rev.1 (Sep 2021)

1. Scope and objectives

Review and update industry standards format according to GPG instructions.

2. Engineering background for technical basis and rationale

None.

3. Source/derivation of the proposed IACS Resolution

ISO 4063:2009
ISO 9017:2017
ISO 10042:2018

4. Summary of Changes intended for the revised Resolution:

Industry standards format has been updated according to GPG instructions.

5. Points of discussions or possible discussions

None.

6. Attachments if any

None.

Technical Background (TB) document for Rec 105 Corr.1 (Jan 2022)

1. Scope and objectives

There was a need to replace the reference to IACS Recommendation 104 by reference to IACS UR W32.

2. Engineering background for technical basis and rationale

None.

3. Source/derivation of the proposed IACS Resolution

None.

4. Summary of Changes intended for the revised Resolution:

Changed paragraph 1.2 contained the reference to IACS Recommendation 104.

5. Points of discussions or possible discussions

None.

6. Attachments if any

None.

Technical Background

for

Recommendation No.106 (NEW, Jul 2009)
***“IACS Guideline for Rule Development -
Ship Structure”***

IACS Hull Panel Task 47
PT47

TB Draft 0.2
20 April 2009

1 Introduction

The IACS Guideline for Ship Structure Rule Development was initiated as a consequence of recent rule development projects in IACS for the Common Structural Rules (CSR) and ongoing work in IMO related to Goal Based Standards (GBS) and Formal Safety Assessment (FSA).

Most parts of the guideline are self-explanatory, and do not require further explanation. Many parts are summarizing principles which are already established as best practice in ship design. However, some items which are considered to be of principal importance are mentioned in Chapter 3 of this Technical Background.

2 Scope and objective

The IACS Guideline for Ship Structure Rule Development is applicable for development of newbuilding structural rules for displacement-type ships intended for worldwide, unrestricted operation. The guideline is mainly intended to be used for development of new structural rules.

The guideline provides principles and recommendations to be followed during the rule development process, as well as general requirements that should be incorporated in the rules that are to be developed.

The objective of the guideline is to form a common basis for development of ship structural rules, by specifying general principles to be followed in the rule development process, as well as general design principles and requirements that should be incorporated into the rules. Having a common basis for rule development ensure that a systematic and unified process is followed in the rule development, and this will contribute to consistency and transparency of the rule requirements.

The guideline should be used to support new rule development, and is made with a view that the rules should be in compliance with the International Maritime Organization's Goal-Based New Ship Construction Standards (IMO GBS), Tier I and Tier II.

3 Points of discussions or possible discussions

Scope

It was decided that the guideline should be as general as possible, and the scope of the guideline is therefore not limited to specific ships. Where needed, ship specific issues are dealt with in each chapter. However, planing high-speed vessels was excluded due to their special characteristics. It was also agreed that the guideline is mainly intended to be used for development of new rules, and not for minor rule changes.

Design life

While the design life is a design parameter, and in principle a ship could be designed for any chosen design life, it was decided to set 25 years as the minimum design life used as basis for the rules, which is in accordance with IMO GBS Tier II and is consistent with Common Structural Rules.

Scatter diagram for FLS

Although ships are typically not trading exclusively in the North Atlantic, it was decided to specify that fatigue loads should be determined under the North Atlantic wave environment, which corresponds to the requirement in IMO GBS Tier II and the Common Structural Rules.

Target safety level

This guidance is in compliance with the safety objectives set by IMO GBS, but it was considered outside the scope of the guideline to define a specific target safety level. Formal Safety Assessment (FSA) is referred to as a general method for defining a target safety level, by requiring that the identified risks are Tolerable and ALARP (As Low As Reasonable Practicable).

Rule format

While the partial factor format (PFF) makes it possible to obtain a more consistent safety level by applying several safety factors, the working stress design (WSD) format is considered as more easy to apply. It was agreed that the PFF format should as a minimum be used for safety critical cases, such as hull girder ultimate strength, while the WSD format may be acceptable for less safety critical cases.

Partial factors

The specific values of the partial safety factors are influenced by many parameters, and it was therefore not found appropriate to give any recommendation with respect to the values. These factors need to be determined from a calibration in each case, based on the choice of characteristic load and strength values, and other assumptions made during the rule development. Furthermore, the service experience of ships is to be taken into account.

Direct calculations

The relation between prescriptive requirements and direct calculations was discussed. It was agreed that in areas where direct calculations more accurately reflect the load and structural behaviour of the structure when compared to load-capacity prescriptive rule requirements, the results from the direct calculations should overrule the prescriptive requirements. However, the baseline minimum requirements defines the floor and scantlings are not to be reduced by any form of alternative calculations. The philosophy is that a coarse approach should be more conservative than a detailed approach. Hence, the prescriptive requirements are targeted to be more conservative than the requirement based on direct analysis.

Accidental Limit States

The scope of Accidental Limit State (ALS) assessment was discussed. While the scope of ALS assessment for most current structural rules is limited, the scope may be increased in future rules as a result of requirements in the IMO Goal Based Standards.

Springing and whipping

Springing and whipping loads were discussed, and it was agreed that these effects are difficult to assess precisely within the format of simplified rule criteria. The formulation of explicit springing and whipping loads were considered to be topics for future investigation.

Characteristic loads

It was difficult to decide on a fixed definition of characteristic load. The general principles used to derive characteristic values are described, but the value can either be chosen as the

most severe value that can be expected during the design life of the ship, or as a fractile in the probability density function for the load. Both approaches are acceptable, as long as the safety factors are calibrated to take account of the choice.

Capacity models

The guideline gives an overview of commonly used capacity models for the failure modes relevant to consider, as well as general principles for how to carry out the capacity assessment. The guideline is however not intended to be very specific, since new and improved methods may be developed in the future.

4 Source/derivation of proposed requirements

N.A.

5 Decision by Voting

N.A.

Submitted by Hull Panel Chairman
24 June 2009

Permanent Secretariat note (July 2009):

The Guideline was submitted to IMO as MSC86/INF.3 on 24 February 2009 and in March 2009 GPG agreed that it should be published as an IACS Recommendation.

This TB, prepared by the Hull Panel, was approved by GPG on 13 July 2009 (ref. 8646cIGf).

Recommendation No. 109 “Acceptance criteria for cargo tank filling limits higher than 98% (on ships constructed before 1 July 2016)”

Part A. Revision History

Version no.	Approval date	Implementation date when applicable
Rev.1 (May 2017)	16 May 2017	-
New (Oct 2009)	08 October 2009	-

• Rev. 1 (May 2017)

.1 Origin of Change:

- Revision of the IGC Code

.2 Main Reason for Change:

The International Code for the Construction and Equipment of Ships Carrying Liquefied Gases in Bulk (IGC Code) was revised.

.3 List of non-IACS Member Classification Societies contributing through the TC Forum and/or participating in IACS Working Group:

None

.4 History of Decisions Made:

A project team was formed to evaluate a HAZID carried out by GTT on cargo tanks' filling limits to address any anticipated amendments expected to occur after the revised IGC Code enters into force and to consider the development of any appropriate Unified Interpretation/understanding with regard to filling limits. The Project Team held a workshop on 2/3 February 2016 and drafted a revision to IACS Recommendation 109. It was decided that since the revised IGC Code specifically stated that isolated vapour pockets were prohibited, that Rec 109 would be revised to apply to the “old” IGC Code and a new Recommendation would be issued for cargo tank filling limits for the revised IGC Code. In addition since the current practice among IACS Societies was to consider the risk of vapour pockets and that the “old” IGC Code did not prohibit them, it was decided to revise Rec 109 to be in line with current practice. The revision was submitted to the Safety Panel on 21 March 2016 for their review and comments.

The Safety Panel reviewed and agreed with the PT's output.

No TB will be issued.

.5 Other Resolutions Changes:

None

.6 Dates:

Original Proposal: 14 July 2014 made by Safety Panel & PT
Panel Approval: 31 March 2017 (Ref: SP14011a)
GPG Approval: 16 May 2017 (Ref: 15097_IGh)

- **New (Oct 2009)**

Panel Approval: 10 Sep 2009 by Statutory Panel
GPG Approval: 08 Oct 2009 (Ref: 8671_IGg)

Part B. Technical Background

List of Technical Background (TB) documents for Rec. 109:

Annex 1. **TB for New (Oct 2009)**

See separate TB document in Annex 1.

Note:

1) There is no separate Technical Background (TB) document for Rev.1 (May 2017).

TECHNICAL BACKGROUND

Recommendation No. 109 (New Oct. 2009)

*“Acceptance Criteria for Increased Cargo Tank Filling Limits Higher than 98%
- IGC Code 15.1.3”*

INTRODUCTION

The IGC Code 15.1.3 permits Administrations to allow higher filling limits than the 98% maximum filling limit permitted by 15.1.1 provided it can be shown that such higher limit will not impair safety of the cargo containment taking into account shape of cargo tanks, location and arrangements of pressure safety relief valves, accuracy of instrumentation and other factors of importance.

A working group organized by SIGTTO for developing proposals for revision of the IGC Code decided to amend 15.1.3 so as to more precisely specify criteria under which higher filling limits may be accepted.

IACS INVOLVEMENT

The IACS Working Party on Gas Tankers did develop a draft interpretation of 15.1.3 giving acceptance criteria for increased filling limits in the mid 1980s. However, this draft was not formally adopted as an UI. The draft acceptance criteria have been used by the industry to some extent as a basis for getting acceptance for higher filling limits by Administrations for some ships.

The SIGTTO working group was made aware that an old IACS draft interpretation existed and asked IACS to propose final acceptance criteria for higher filling limits that could be included in a revised IGC Code.

IACS Statutory Panel agreed to develop such criteria as input to the SIGTTO working group and established a Project Team to carry out the task.

AGREED ACCEPTANCE CRITERIA

Compared to the old draft UI the following points may be noted:

- ‘Functional requirements’ were developed and included under a ‘General’ introductory paragraph.
- The formulae in the old draft for corrections due to tolerances of temperature gauges was an expression correlating gauge tolerances and loading temperature vs critical temperature for the product to give a resulting volume expansion. This has been changed into a formulae giving expansion as the product of gauge tolerance and the volumetric expansion factor for the product.

- The correction factor in the original draft for tank calibration error has been omitted since it was found that such error has no significant influence on filling limits expressed as percentage.
- A correction factor accounting for the volume expansion resulting from the pressure rise from opening pressure of pressure relief valves to full relieving capacity has been added. This pressure rise is taken to be 20% of the set opening pressure of the PRV's according to IGC Code 8.5.
- Corrections for tolerances on PRV's set opening pressure (IGC 8.2.5) were found not to be applicable for pilot operated PRV's and were consequently not included.
- A factor expressing an operational margin to account for operator's reaction time, valve closing time and product flow back from cargo piping has been added. This margin has been set to min. 0.1%.
- A specific requirement that under conditions of list and trim given in IGC Code 8.2.17 the suction funnels of the PRV's shall be min. 0.4D of funnel diameter above the liquid surface and that no isolated vapour pockets shall be formed.
- After some discussions it was agreed to keep a maximum filling of 99.5% as in the old draft.

POINTS OF DISCUSSIONS

The old draft interpretation set a maximum permitted filling limit of 99.5% at reference temperature. With the detailed outline of correction factors in the revised acceptance criteria the necessity of having this upper limit was discussed.

After some discussions, and carrying out sensitivity studies which varied the Alpha (α) values, it was recognized that Alpha 4 (α_4) (operational margin) had a significant impact on the filling limit, but could not be defined precisely enough to control that limit. Accordingly, it was agreed to keep a maximum filling of 99.5% as in the old draft.

The Project Team completed the task by the end of April 2009 with the outcome including a draft UI. Meanwhile, the PT reported to the Statutory Panel that filling limits above 99.5% had been granted for some gas carriers. However, the PM thought that no rationale for this acceptance was given and consequently no discussions took place in the PT.

No consensus was reached as to whether the draft UI shall be retrospectively applied to existing gas carriers in the Statutory Panel. Taking into account the PT's report as mentioned above, and considering that:

- 1) no consensus was reached as to whether the draft UI shall be retrospectively applied to existing gas carrier in the Statutory Panel;
- 2) some members suggested that this criteria should be implemented by members on voluntary basis; and

3) the benefit of having an IACS Technical Resolution available for the IGC Code review, in the end, the Statutory Panel agreed that this criteria should be a Recommendation at this stage and may be reinstated as an IACS UI depending on the outcome of the revision of the IGC Code.

Submitted by Statutory Panel Chairman
10 September 2009

Permanent Secretariat note (October 2009):

New Recommendation No.109 was approved by GPG on 8 October 2009 (ref. 8671_IGg).

Recommendation No.110 “Guideline for Scope of Damage Stability Verification on new oil tankers, chemical tankers and gas carriers”

Summary

This revision aims at clarifying the vague expressions in IACS Rec.110 (2010 Rev.1) to comply with IMO guidelines MSC.1/Circ.1461 and MSC/Circ.406/Rev.1, and further improve it taking into account IACS URL5 Rev.3.

Part A. Revision History

Version no.	Approval date	Implementation date when applicable
Rev.2 (Mar 2021)	18 March 2021	1 July 2021
Rev.1 (Nov 2010)	5 November 2010	1 January 2011
New (Nov 2009)	20 November 2009	1 January 2010

- **Rev.2 (Mar 2021)**

1 Origin of Change:

- x Suggestion by IACS member
- x Based on IMO guidelines MSC.1/Circ.1461 and MSC/Circ.406/Rev.1
- x Based on IACS URL5 Rev.3

2 Main Reason for Change:

To revise the Recommendation in accordance with IMO guidelines MSC.1/Circ.1461 and MSC/Circ.406/Rev.1 and taking into account IACS URL5 Rev.3.

3 List of non-IACS Member classification societies contributing or participating in IACS Working Group:

None

4 History of Decisions Made:

The Recommendation was revised by Project Team PT PS40/2018 established by IACS Safety Panel. The work was carried out by correspondence.

5 Other Resolutions Changes:

None

6 Any hinderance to MASS, including any other new technologies:

None

7 Dates:

Original Proposal: 23 July 2019 (Made by: PT PS40/2018)

Panel Approval: 2 March 2021 (Ref: PS17025aISza)

GPG Approval: 18 March 2021 (Ref: 18011_IGg)

• Rev.1 (Nov 2010)

.1 Origin of Change:

- Request by non-IACS entity (UK MCA)
- Suggestion by an IACS member
- Based on IMO Regulation (Outcome of SLF 52)

.2 Main Reason for Change:

To revise the Recommendation in accordance with the comments and proposals provided by UK MCA and IACS Statutory Panel and submit the revised Recommendation to SLF 53.

.3 List of non-IACS Member classification societies contributing through the TC Forum and/or participating in IACS Working Group:

None

.4 History of Decisions Made:

The Recommendation was revised by Project Team PT25 established by IACS Statutory Panel according to the results achieved by correspondence under Statutory Panel subject number SP10006i and the extensive comments made by UK MCA (see Form 1 approved by IACS GPG on 12 August 2010). Majority of work was accomplished by correspondence.

Kick-off meeting was held to consider/discuss the results achieved by correspondence under Statutory Panel subject number SP10006i and comments provided by MCA to IACS Rec.110, to consider the need to establish a cooperation with UK MCA, to agree on the scope of work to be carried out by the PT and to divide the agreed scope of work into the equal sets to be assigned to each PT Member.

PT Status Report was submitted to IACS Statutory Panel on 30th August 2010. The report was considered by the Panel at its 12th meeting. It was also agreed to submit the revised Rec. 110 to SLF 53 separately from the UK paper as an IACS information document.

The Recommendation was further revised by the PT as per the output from the 12th Statutory Panel meeting and submitted to the Panel for approval.

.5 Other Resolutions Changes

None

.6 Dates:

Original Proposal: *24 September 2010 Made by the PT25 of the Statutory Panel*
Panel Approval: *25 October 2010*
GPG Approval: *05 November 2010 (Ref: 10038bIGg)*

• **New (Nov 2009)**

.1 Origin of Change:

Based on IMO Regulation (Outcome of SLF 51)

.2 Main Reason for Change:

To submit the approval procedures used by IACS Members for damage stability calculations to SLF 52.

.3 List of non-IACS Member classification societies contributing through the TC Forum and/or participating in IACS Working Group:

None

.4 History of Decisions Made:

This Recommendation was developed by Project Team PT24 established by IACS Statutory Panel.

.5 Other Resolutions Changes

None

.6 Dates:

Original Proposal: *18 September 2009 Made by PT24 of the Statutory Panel*
Panel Approval: *10 November 2009*
GPG Approval: *20 November 2009 (Ref: 9559aIGh)*

Part B. Technical Background

List of Technical Background (TB) documents:

Annex 1 **TB for New (Nov 2009)**

See separate TB document in Annex 1.

Annex 2 **TB for Rev.1 (Nov 2010)**

See separate TB document in Annex 2.



Note: *There is no separate Technical Background (TB) document for Rev.2 (Mar 2021).*

Technical Background for Recommendation No.110 New (Nov 2009)

1. Scope and objectives

Following extensive debate at SLF 51, the Sub-Committee noted IACS's intention to submit the approval procedures used by its members for damage stability calculations to SLF 52. Subsequently, SLF Chairman invited IACS to provide the information on the scope of damage stability verification uniformly applied by its members to SLF 52.

2. Engineering background for technical basis and rationale

Bearing in mind the above IACS decided to develop a Recommendation in terms of Scope of Damage Stability Verification on new oil tankers, chemical tankers and gas carriers – with the aim to provide a guideline to obtain a reference uniform approach for verifying damage stability under the following IMO Instruments: SOLAS, ICLL, MARPOL Annex I, IBC Code and IGC Code.

3. Source/derivation of the proposed IACS Resolution

Outcome of IACS Statutory Panel 9th Meeting on the Approval Procedures used by IACS members for Damage Stability Calculation.

4. Summary of Changes intended for the revised Resolution:

Not applicable

5. Points of discussions or possible discussions

At the first stage the core of Scope of Damage Stability Verification on new oil tankers, chemical tankers and gas carriers was developed and unanimously agreed by all IACS Members. Then the regulations of existing IMO instruments (i.e. conventions, codes, guidelines and circulars) and IACS resolutions (i.e. Procedural Requirements, Unified Requirements, Unified Interpretations, etc) applicable to damage stability of new oil tankers, chemical tankers and gas carriers were identified. Finally the detailed content of the Scope of Damage Stability Verification on new oil, chemical tankers and gas carriers has been developed and approved in the form of IACS Recommendation No.110.

6. Attachments if any

None

Technical Background for Recommendation No.110 Rev.1 (Nov 2010)

1. Scope and objectives

Following the debate at SLF 52, the Sub-Committee invited interested Parties to provide their comments on the IACS Rec.110 with a view to develop the new IMO Guidelines. IACS's intention to continue the work on improvement of Rec. 110 and submit the revised Recommendation to SLF 53 was noted by Sub-Committee.

2. Engineering background for technical basis and rationale

IACS Rec.110 was amended on the basis of IACS Members practical experience on damage stability verification on new oil tankers, chemical tankers and gas carriers.

3. Source/derivation of the proposed IACS Resolution

The results achieved by correspondence under Statutory Panel subject number SP10006i, comments provided by MCA to IACS Rec. 110, existing procedures used by IACS members for damage stability calculation and the outcome of 12th Statutory Panel meeting (Statutory Panel Task No.33).

4. Summary of Changes intended for the revised Resolution:

See the attached Summary of discussion on the comments to IACS Rec. 110.

5. Points of discussions or possible discussions

See the attached Summary of discussion on the comments to IACS Rec. 110.

6. Attachments if any

Summary of discussion on the comments to IACS Rec. 110.

Discussion on the comments to IACS Rec. 110 – Summary

Comments to IACS Rec.110	PT/DSV remarks
<u>MCA Comment on IACS Rec.110</u>	PT agreed to submit the revised Rec. 110 to SLF 53 separately from the UK paper as an IACS information document.
1. Definitions required for clarification/uniform interpretation	
1.1 SOLAS	“SOLAS” should read “MARPOL”.
<p>1.1.1. Annex 1 regs 28.1.2 and 28.1.3 both rely upon an understanding of what constitutes the “machinery space”. In this respect the machinery space shall be that part of the vessel which contains the propelling engine and lies between main transverse watertight bulkheads located below the bulkhead deck, and shall be limited by the upper watertight boundary of this space.</p> <p>Consequently, separate accommodation which lies above this space should be considered prone to damage as prescribed in reg 28.4.3 and progressive flooding in the residual range should be applied up to the first boundary that meets reg 28.3.1.</p> <p>In addition, subject to application of reg 28.2.5.2 in the case of damage required by reg 28.1.3, trunks and extensions to the machinery space should be considered prone to damage where these lie above the bulkhead deck but fwd or aft of the main transverse watertight bulkheads which limit the extent of the machinery space below this deck, and also in any case where an extension to the machinery space below the bulkhead deck is recessed by a distance less than the transverse extent of penetration of assumed damage.</p> <p>Progressive flooding in the residual range following damage to such a trunk or extension</p>	<p>No action from the PT is required. PT agreed that a specific UI for Reg. 28 should be developed to clarify that the wording “machinery space” based on the definitions contained in SOLAS.</p>

<p>should be applied up to the first boundary that meets reg 28.3.1.</p>	
<p>1.1.2. Annex 1 reg 28.1.2 excludes application of damage to the machinery space of tankers more than 150m but not exceeding 225m where the machinery space is “located aft”. In this context it is considered this means that all parts of the fwd watertight bulkhead bounding the machinery space (as defined above) should lie aft of midships where it bounds the shell.</p> <p>Furthermore, the restriction on applying damage to a machinery space located aft does not remove the obligation to consider side and bottom damages of a lesser extent which occur within this portion of the vessel.</p>	<p>Reg. 28.1.2 does not exclude application of damage to the machinery space, but we agree with the proposal to define the term “located aft” specifically for the purpose of application of Reg. 28.1.2 and Reg. 28.1.3. The following interpretation could be proposed for the further development:</p> <p>“machinery space is located aft “ means that all parts of the fwd watertight bulkhead bounding the machinery space should lie aft of midships where it bounds the shell and after of the cargo zone. The step formed by the afterpeak tank shall not be damaged as in accordance with ICLL, Reg.27.12.d) and MARPOL, Reg. 28.2.5.2.</p> <p>PT agreed that no revision is needed for Rec.110.</p>
<p>1.1.3. Annex 1 reg 28.3.4 requires that residual stability is assessed in the “intermediate stages” of damage and that the stability should be “sufficient” in all such stages.</p> <p>We are in agreement with your proposals with respect to these issues, that six stages of primary flooding should be considered and that the final stage stability criteria should also be applied during intermediate stages.</p>	<p>PT has no specific comment.</p>
<p>1.1.4. Annex 1 reg 28.3.5 requires that where cross-flooding arrangements are fitted which do not meet the requirement for the flooded compartment to be considered common with the damaged compartment, full compliance with residual criteria should be met in all intermediate stages of flooding and at equilibrium without these being taken into account.</p> <p>This is commonly interpreted as meaning that cross-flooding fittings are not permitted, so should be ignored completely. We are in agreement with your interpretation, that this</p>	<p>PT has no specific comment.</p>

<p>requires all primary flooding stages to be completed before cross-flooding is evaluated, with all primary and cross-flooding stages required to meet residual criteria.</p> <p>We also consider 3 stages of cross-flooding to be appropriate for this purpose and that cross-flooded compartments may be considered common if a calculation made in accordance with Resolution MSC.245(83) shows equalisation within 60 seconds.</p>	
<p>1.2. IBC/IGC Codes</p>	
<p>1.2.1. Regulation 2.8.1 in both Codes relies upon an understanding of what constitutes a “machinery space located aft”.</p> <p>In this respect the machinery space considered shall be that part of the vessel which contains the propelling engine and lies between main transverse watertight bulkheads located below the bulkhead deck, and shall be limited by the upper watertight boundary of this space. <i>This limited application contradicts the more general definition in reg 1.3.</i></p> <p>Separate accommodation which lies above this space should be considered prone to damage and any progressive flooding in the residual range should be applied up to the first boundary that meets reg 2.7.8.</p> <p>In addition, subject to application of reg 2.7.4 in the case of damage required by regs 2.8.1.3, 2.8.1.5 and 2.8.1.6 of the IBC Code and regs 2.8.1.3 and 2.8.1.6 of the IGC Code, trunks and extensions to the machinery space should be considered prone to damage where these lie above the bulkhead deck but fwd or aft of the main transverse watertight bulkheads which limit the extent of the machinery space below this deck, and also in any case where an extension to the machinery space below the bulkhead deck is recessed by a distance less than the transverse extent of penetration of assumed damage.</p> <p>Progressive flooding in the residual range following damage to such a trunk or extension should be applied up to the first boundary that meets reg 2.7.8.</p> <p>As you are aware, we have had issues with this interpretation where trunks to the</p>	<p>See the comment to 1.1.1.</p>

<p>machinery space have extended beyond the limiting main watertight bulkheads but have not been effectively separated by watertight bulkheads from the accommodation or other ancillary compartments as the openings were closed with fire doors and not weathertight or watertight doors as required.</p>	
<p>1.2.2. With respect to the definition of “located aft” in the context of the excluded machinery space damage cases considered at 2.2.1 above, it is considered this means that all parts of the fwd watertight bulkhead bounding the machinery space (as defined above) should lie aft of midships where it bounds the shell.</p> <p>Furthermore, the restriction on applying damage to a machinery space located aft does not remove the obligation to consider side and bottom damages of a lesser extent which occur within this portion of the vessel.</p>	<p>See our comment to 1.1.2.</p>
<p>1.2.3. Reg 2.9.1.3 of both Codes requires that residual stability is assessed for “intermediate stages” of damage and that the residual stability standard to be applied should not be “significantly less” than that required for compliance in the final stage.</p> <p>We are in agreement with your proposals with respect to these issues, that six stages of primary flooding should be considered and that the final stage stability criteria should also be applied during intermediate stages.</p>	<p>PT has no specific comment.</p>
<p>1.2.4. Reg 2.7.6 of both Codes require that where cross-flooding arrangements are fitted which do not meet the requirement for the flooded compartment to be considered common with the damaged compartment, full compliance with residual criteria should be met in all intermediate stages of flooding and at equilibrium without these being taken into account.</p> <p>This is commonly interpreted as meaning that cross-flooding fittings are not permitted, so should be ignored completely. We are in agreement with your interpretation, that this requires all primary flooding stages to be completed before cross-flooding is evaluated, with all primary and cross-flooding stages required to meet residual criteria.</p> <p>We also consider 3 stages of cross-flooding to be appropriate for this purpose and that</p>	<p>PT has no specific comment.</p>

<p>cross-flooded compartments may be considered common if a calculation made in accordance with Resolution MSC.245(83) shows equalisation within 60 seconds.</p>	
<p>2. Items to change</p>	
<p>2.1. At section 3.2 we think the wording may be confusing. We suggest the following modifications may clarify the intended meaning.</p> <p>“.... In general, for non approved loading conditions (by the Administration or RO), <i>approved</i> KG/GM limit curve(s) <i>from stability information</i> or approved loading instrument software satisfying the stability requirements (intact and damage) for the <i>proposed loading condition</i> should be used <i>to verify compliance on board</i>.</p> <p>Within the scope of the verification determined as per the above, all potential or necessary damage <i>scenarios</i> should be determined <i>and assessed</i> taking into account the damage stability criteria.</p> <p>Damage stability verification <i>and approval requires</i> a review of submitted calculations and supporting documentation with independent check calculations to confirm <i>damage stability calculation results comply</i> with relevant stability criteria.</p> <p>Examination and approval of the loading instrument software installed on board and to be used for assessing damage stability should also be carried out.”</p>	<p>The following revision have been agreed by the PT:</p> <p>“.... In general, for non approved loading conditions (by the Administration or RO), approved KG/GM limit curve(s) or approved loading instrument software satisfying the stability requirements (intact and damage) for the draugh range to be covered should be used to verify compliance on board.</p> <p>Within the scope of the verification determined as per the above, all potential or necessary damage scenarios should be determined and assessed taking into account the damage stability criteria.</p> <p>Damage stability verification and approval requires a review of submitted calculations and supporting documentation with independent check calculations to confirm damage stability calculation results comply with relevant stability criteria.</p> <p>Examination and approval of the loading instrument software installed on board (and to be used for assessing intact and damage stability) should also be carried out.”</p>
<p>2.2. It would be our understanding that unenclosed superstructures would not be included in KN data except in the case set out at section 3.3, when we would expect flooding points (including windows) incapable of weathertight closure to be included in any list determined in accordance with paragraph 3.4.2.6.</p>	<p>PT agreed that the following should be added to the second paragraph of IACS Rec.110, Section 3.3:</p> <p>Flooding points (including windows) incapable of weathertight closure to be included in any list</p>

<p>Full compliance with residual stability criteria must be achieved before any such point becomes immersed within the residual range.</p>	<p>determined in accordance with paragraph 3.4.2.6. Full compliance with residual stability criteria must be achieved before any such point becomes immersed.</p>
<p>2.3. With particular reference to any submission which includes critical KG or GM data we suggest there should be an entry at paragraph 3.4.2.11 requiring that any initial conditions or restrictions which have been assumed in the derivation of such data, and which must therefore be met in service, should be stated.</p>	<p>Agreed by the PT.</p>
<p>2.4. At paragraph 3.4.3.2 it is stated that intermediate stages only require to be considered where it is “obvious that there is some risk to achieve critical trim and/or stability parameters in the intermediate stages”.</p> <p>Consideration of intermediate stages is a requirement of the various international instruments. Whilst its evaluation may prove to be of no significance in the majority of cases it is not an optional consideration and this relaxation/interpretation is open to potential abuse.</p>	<p>To solve the matter it was agreed</p> <p>to replace the wording “intermediate conditions, as” with “intermediate flooding” in the first sentence of paragraph 3.4.3.2;</p> <p>to add the reference to paragraphs 6.8 and 9.2 into the first sentence of paragraph 3.4.3.2 after the words: “cross-flooding” and the reference to paragraphs 6.9 after the words “progressive flooding”;</p> <p>to amend the second sentence of paragraph 3.4.3.2 as follows:</p> <p>“The intermediate stages for cargo outflow and sea water inflow should be checked. If any stability criteria during intermediate stages shows more severe values than in the final stage of flooding this intermediate stages should also be submitted.”;</p> <p>to amend paragraphs 4.1.e) as follows:</p> <p>“Minimum tank filling levels required to achieve compliance with the applicable stability criteria; and”</p> <p>and to amend the second sentence of paragraph 9.1 as</p>

	<p>follows:</p> <p>“If any stability criteria during intermediate stages shows more severe values than in the final stage of flooding this intermediate stages should also be submitted”.</p>
<p>2.5. We consider that section 4 constitutes advice to Class surveyors on what methods of operation are permissible, and what each one requires to be examined and approved. On this basis we would consider that a better title may be “<i>Permitted Modes of Operation – Descriptions/Assumptions</i>” and the following modifications to the text are offered for consideration :</p> <p>“In considering the scope of the verification to be conducted, consideration of the <i>intended mode of operation is required.</i></p> <p>The following <i>modes of operation are permitted :</i></p> <ul style="list-style-type: none"> a) <i>Adherence to service loading conditions close to the approved loading conditions from the stability booklet (see paragraph[s 4.1 and] 4.2); or</i> b) <i>Adoption of service loading conditions other than approved loading conditions which have been checked on board to show compliance with the approved [intact and] damage stability limiting curves (where provided) (see paragraph 4.3); or</i> c) <i>Adoption of service loading conditions other than approved loading conditions which have been checked with an approved on-board stability software capable of [intact and] damage stability verification (Type 2 or 3 of IACS UR L5, Rev. 2, Corr.1 Nov 2006) based upon KG/GM limit curve(s) or direct calculation (see paragraph 4.5).</i> <p><i>In the case of vessels which intend to operate by adherence to approved loading conditions only when in service, and for which no means has been submitted or approved in relation to verification of loading conditions other than the approved loading conditions, suitable instructions should be included in the stability booklet/loading manual that adoption of such unapproved loading conditions in service is prohibited unless these are submitted for the</i></p>	<p>PT agreed to keep the existing text. Because this is the responsibility of IMO to define the allowed deviation from the approved loading conditions.</p>

specific approval of the Administration or RO.”

Note: clauses b) and c) refer to intact stability. As the guidance is supposed to refer to damage stability only, these references should really be deleted along with that at paragraphs 4.3 a), 4.5 a), 4.5 b) and any others identified. However, if the references to intact stability are to be retained the title of the document shall require amendment.

2.6. Section 4.1 reflects the submission and approval of individual fixed loading conditions described in paragraph 4 a). We would suggest that the word *displayed* in the first line may better be replaced with *presented*.

Given that the conditions are fixed and all require to be individually verified and approved as meeting damage criteria we would question some of the guidance included.

At 4.1 a) we would question whether “alternate” is required as this is implied in “any intended condition”, and ballast conditions do not need to be considered for damage.

At 4.1 c) a fixed loading condition cannot really apply or convey a restriction, just another alternative “intended condition”.

At 4.1 d) we agree that the full range of operating SG should be covered but safe carriage in between these SGs cannot be inferred, particularly if the wording “identical to” is retained at paragraph 4 a).

At 4.1 e) an approved fixed condition cannot be used to set a general limit, such as minimum filling levels for one or more tanks, as it is not permitted to load alternate conditions based upon this information.

4.1 f) appears to be an extension of 4.1 a) in that it constitutes another set of “intended conditions”.

PT revised Section 4.1 as follows:

“4.1 Specific loading patterns

Ship specific design loading patterns and loading restrictions should be clearly presented in the stability booklet. The following items should be included:

- a) Any required and intended loading conditions (including the ones corresponding to multiple freeboards when so assigned to the vessel), i.e. symmetrical/unsymmetrical, homogeneous/alternating or ballast/partial/full;
- b) Types (e.g. oil, noxious liquid substances and LNG) of liquid cargo allowed to be carried;
- c) Restrictions to different liquid loads to be carried simultaneously;
- d) Range of permissible densities of liquid loads to be carried; and
- e) Minimum tank filling levels required to achieve compliance with the applicable stability criteria.

For the verification of damage stability all loading

	<p>conditions presented in the stability booklet except for ballast, light ship and docking conditions are to be examined.”</p>
<p>2.7. We would question whether the “matrix of loading conditions” described in section 4.2 constitutes a legitimate means of verifying damage stability for conditions which are not individually assessed and approved. Paragraph 4.5 a) implies that these conditions are previously approved and may be used as base data for a Type 2 loading program.</p> <p>We would consider that practical application of such matrices of conditions would prove to be problematic in service as their accuracy depends upon the assumed input conditions, including draught, trim, initial GM, subsidiary tankage in way of the critical cargo tank for damage purposes (particularly for two compartment ships) and the cargo SG.</p> <p>It is unclear how such conditions would be used in practice, but it is assumed that the closest approved condition to a live loading condition would be that with the same draught and trim, and then the closest tank fillings and intact GM. The problem comes with permitting variation in these items, as for any condition on the KG/GM limit a variation gives a 50% chance of non-compliance.</p> <p>Selecting conditions in relation to their cargo tank fillings and initial GM, in preference to the displacement/draught and trim is problematic as this may lead to acceptance of conditions which would fail if examined directly for compliance.</p> <p>Unless such matrices of conditions can be presented in such a manner that it is possible to demonstrate without any doubt to PSCI that a loading condition, which does not correspond with any of them directly, fully meets damage criteria we think this method should be removed.</p> <p>There is no difference in principle between loading approximately to a matrix condition as there is to a fixed approved condition considered in paragraph 4.1.</p>	<p>“Matrix of Permissible Loading Conditions” in item 4.2 of the current Rec.110 should remain as Option such that it may be used by Member(s).</p>

<p>2.8. To more closely reflect the guidance in MSC/Circ.406/Rev.1, the first line of section 4.3 should refer to "... gas/chemical vessels <i>which operate as parcel tankers, ...</i>".</p>	<p>PT has no specific objection.</p>
<p>2.9. In section 9.3 there is reference to an alternative method "i)" of considering substitution of initial tank content with sea water. This method refers to Annex 5 but does not follow the guidance in Annex 5, which gives the calculation method proposed for the method which precedes alternative method "i)". Annex 5 does not propose a linear transition for SG, so this reference and calculation method should be deleted.</p>	<p>PT agreed that the reference should be removed, but the calculation method should be kept.</p>
<p>2.10. It is noted however that the calculation method proposed at alternative method "ii)" solves the issue of treating an empty tank which is initially above the condition waterline, and only floods in the latter damage stages.</p> <p>We do not generally favour employing two alternate methods of calculation for considering the filling/transitional filling of tanks which lie on or below the waterline and see little purpose in employing one such as this, which only covers empty tanks when tanks may be full, part full or empty in any particular loading case, for this purpose.</p> <p>However, we do support use of this methodology to address the filling of a tank which immerses only in the last few flooding stages and is intersected by or below the initial waterline.</p>	<p>PT agreed to keep the existing text, i.e. alternative methods should be allowed as they may be equally as valid.</p>
<p>3. Items to Add/Consider</p>	
<p>3.1. For the purpose of providing comprehensive guidance it shall be necessary to add a definition for the meaning of "approved loading condition" which should reflect that from the operational guidance presently under preparation by others.</p>	<p>PT agreed that there is no need to develop a new definition for the well understood term, i.e. an approved loading condition is one which has been directly examined and endorsed by Administration/RO. This definition "An approved loading condition is one which has been specifically examined and endorsed by Administration/RO" will be added to the end of</p>

	paragraph 4 (before paragraph 4.1).
<p>3.2. For the purpose of operating a vessel which has approved loading conditions alone, it is permitted to transition from the approved departure condition to the approved arrival condition required to be submitted and approved by the various international instruments. If this is not the case then vessels would be inoperable.</p> <p>Where this transition involves substantial consumption of fuel and other consumables, and/or substitution with ballast on passage, each stage of the voyage should be separately considered and approved with an appropriate allowance made for free surface.</p> <p>In this respect, no condition is fixed once the voyage commences and it is not expected to check stability throughout a voyage where no means to achieve this is provided. Consequently it is proposed that the wording of paragraph 4 a) is modified to that shown at 2.5 a) above.</p>	PT agreed that this matter is properly covered by paragraph 6.5.
<p>3.3. Paragraph 4.2 introduces an apparent anomaly, as we are advising that vessels must always be loaded closely to an approved condition, otherwise the loading condition is invalid (unverified for damage stability in particular) and has to be submitted to the Administration or RO for prior approval.</p> <p>Yet we are also indicating that the existing provisions must permit transition between approved departure and arrival conditions, otherwise the existing instruments and approvals make no sense.</p> <p>To make any sense of this I think we need to differentiate between changes through usage of consumables, provided that significant ballast substitution is covered, and variation from approved loading conditions caused through significant changes to the initial level/distribution of cargo or ballast carried.</p> <p>We need to provide a definition of the safe (maximum) deviation from an approved loading condition before it becomes invalid and the revised loading condition must be</p>	See the remark to comment 2.7.

<p>considered and approved in its own right.</p> <p>For this we have previously suggested a variation based upon a variation of cargo or ballast mass of 1% in any individual tank and variation of 2cm in the overall calculated fluid KG or GM.</p> <p>It may be more flexible to expand these limits to reflect the permitted calculation tolerances (ie the allowed variation in the original condition from what has been calculated) of 2% variation in of cargo or ballast mass in any individual tank and 5cm or 1% x KG variation in the overall calculated KG or GM (whichever is less). It is difficult to justify limits beyond these values.</p> <p>Overall one would also have to set a maximum variation in total cargo and ballast tank content of 2% by mass, as a means of controlling the overall displacement and draught if tanks other than cargo or ballast are also varied.</p>	
<p>3.4. Although it is accepted that critical KG/GM data are an accepted method for determining the stability of loading conditions other than approved loading conditions, and that their use is provided for and promoted in international instruments, their use does present some difficulty.</p> <p>In particular, we would recommend that their use is only permitted and approved if any initial conditions upon which their results rely can be readily understood and presented in the stability booklet and checked on board, using a calculation sheet or other check off list.</p> <p>Where on-board loading software is used to check compliance with critical KG/GM data stored for this purpose, the approval of the software should also ensure that all initial conditions (if any) which justify use of the critical KG/GM data are met for the loading condition under consideration, and for this to be confirmed in the printout.</p> <p>One initial condition to be fulfilled would be the maximum permitted initial heel variation from upright.</p>	<p>PT decided to add the footnote against the title of section 4.3 “To avoid difficulties associated with developing suitable KG/GM limit curves and their restriction on operational capacity it is recommended that an approved Type 3 stability software is fitted on board.”</p>

<p>It is also essential to ensure that critical KG/GM data fully reflect the arrangement of the vessel, particularly if the centreline division is not directly on centreline (which may require port/stbd sets) and in cases where two compartment damage applies (where limiting data must also include one compartment damages and other lesser cases where these may be more severe).</p>	
<p>3.5. At section 4.4, reference is made to the necessity of keeping the vessel upright as far as practicable, which is basic good seamanship.</p> <p>Noting that a 20m beam tanker shall exhibit an additional immersion of 175mm at the deck edge for an initial heel of 1 degree, and the adverse effects such an initial heel shall have on restoring moment and immersion of air pipes after damage, we would prefer to see this limit reduced to no more than 0.5 degrees.</p> <p>It is our opinion that loading programs of Type 3 should normally be arranged to calculate all damage stability scenarios for both sides of the vessel, to reflect the variations in typical parcel tanker operation, in which case any initial heel shall have an adverse effect on stability compliance to that side.</p> <p>Accepting that it may not prove feasible to always bring a vessel upright prior to departure, we would suggest that any loading program which is approved to undertake calculations to one side only (on the basis that the loading shall always be symmetrical) should always be arranged to apply damage in the direction of heel where one is recorded, and also to give an error should the heel exceed the maximum permitted value.</p> <p>The ability to consider vessel truly symmetric shall depend upon the disposition and arrangement of the internal compartments and any progressive flooding points within the poop accommodation and similar areas. Experience shows that these elements are rarely symmetric.</p>	<p>Please be referred to the tolerance indicated in L5 for equilibrium angles. The comments look like amendments to L5 (not to Rec.110).</p>
<p>3.6. Section 6.1 makes a modification to the standard constant displacement damage</p>	<p>PT agreed to amend the last sentence of paragraph 6.1</p>

<p>consideration to reflect application for tank vessels with partially or wholly pre-filled tanks. In this respect the treatment of cross-connected tanks needs to be considered during primary and secondary flooding.</p> <p>Where tanks are effectively connected in accordance with section 6.8 they are considered to be common and to flood together. Consequently any initial content should be deducted from both tanks to determine the final waterline and residual GZ.</p> <p>Where tanks are cross-connected by small ducts, cross-flooding shall be delayed until after primary flooding and equalisation are complete. In this circumstance the final filling shall be an addition to the total ship displacement if the compartment floods, or there shall be a reduction in displacement if there is a nett outflow. However, there shall be no loss of buoyancy (KNs) as the cross-connected compartment is not opened to the sea directly.</p>	<p>as follows:</p> <p>“For the intermediate stages of flooding and the equalisation with compartments cross-connected by small ducts, i.e. not opened to the sea directly, the added weight method is used”.</p>
<p>3.7. Paragraph 6.6.2 does not appear particularly clear in its meaning and seems to cover two distinct issues. Firstly, that large trims may develop between depart and arrival conditions, in which case damage cases toward the immersed end may become limiting and, secondly, where ballasting is undertaken to counteract this effect the free surface allowances should be correctly considered and any distinct intermediate loading conditions with ballast should also be assessed for damage compliance.</p>	<p>PT agreed that paragraph 6.6.2 is intended to clarify on how to treat the significant operational trim. The matter related to the free surface effect is properly covered by paragraph 6.5 (see the remark to comment 3.2). So, no revision is needed.</p>
<p>3.8. Section 6.8 (3rd paragraph) requires that cross-flooding arrangements, being those arrangements which take more than 60 seconds to achieve equalisation, should complete equalisation in a maximum period of 10 minutes. It is implicit from this that cross-flooding arrangements which take longer than 10 minutes to complete equalisation should not be taken as effective and ignored.</p>	<p>PT agreed that the maximum period of 10 minutes is in line with SOLAS damage stability requirements. The final decision should be taken by the Administration/RO.</p>
<p>3.9. Section 6.8 details that compartments connected with cross-flooding arrangements which complete equalisation in 60 seconds or less should be considered as common, and to flood together in parallel during primary flooding stages, whereas those which complete equalisation between 1 and 10 minutes should be considered to cross-flood as a secondary stage as described in paragraph 9.2 2).</p>	<p>PT agreed that this is already covered by Resolution MSC.245(83) and no additional clarification is needed.</p>

<p>In making any assessment of cross-flooding time using Resolution MSC.245(83), reference should also be made to the need to ensure that sufficient air pipe area is provided to enable such cross-flooding to complete effectively, and not to be restricted by increased air pressure above the waterline in the equalised tank. In this respect a minimum air pipe sectional area of 10% of the cross-levelling duct should be provided.</p>	
<p>3.10. Section 6.9 (2nd paragraph) describes treatment of compartments which are progressively flooded through immersion of a downflooding point which becomes permanently immersed. It is only logical to assume that such a space will flood during those primary stages of flooding up to and including equilibrium which occur after the downflooding point immerses, not over all six stages.</p>	<p>PT agrees with the view expressed by MCA, but sees no real need to amend Rec.110.</p>
<p>3.11. We would suggest rephrasing the wording of paragraph 7.2.1 to advise that all cases of lesser damage should be assessed to ensure they do not result in a more severe residual condition than that determined for a damage of full extent. In particular single compartment cases should be considered for two compartment ships and the possibility of lesser cases becoming critical at elevated trim levels should be assessed.</p> <p>Where it is apparent that lesser cases of damage are always less severe than a damage of full extent, then consideration may be given to omitting such cases from the standard damage cases run by a loading program of Type 3.</p>	<p>PT agreed to amend paragraph 7.2.1 as follows:</p> <p>“If any damage of a lesser extent than the maximum damage specified in 7.1 would result in a more severe condition, such damage should be considered (see paragraph 4.5).”</p>
<p>3.12. In relation to section 7.3 we would caution that surveyors are tempted to consider the possible effects of lesser damage cases before the event, as the consequences of individual damages cannot always be foreseen and may reverse with changes in the initial conditions, such as cargo SG or tank filling level, or the omission of deck tanks from a damage case.</p> <p>It is best practice to always define and evaluate lesser cases rather than to attempt to prejudge which ones may prove to be more severe and therefore worthy of examination.</p>	<p>Just noted. No amendments to Rec. 110 were approved by the IACS Statutory Panel.</p>
<p>3.13. In relation to consideration of homogeneous loading conditions and partial loading conditions described in section 8.1, it must be borne in mind that if there is no logical</p>	<p>See the remark to comment 2.5.</p>

<p>progression in tank fillings as the SG or cargo mass increases, then the master cannot effectively interpolate between such conditions to determine compliance of an intermediate case. Interpolation between loading conditions in this way cannot generally be regarded as sufficient to meet statutory requirements and is not permitted.</p>	
<p>3.14. Similarly, the consideration of symmetrical or unsymmetrical loading patterns in section 8.2, and zig zag loading patterns in particular, determined for a narrow range of SG does not imply the ability to carry empty tanks under any circumstance and inferring compliance in this way, although currently seen to be common, should not be permitted.</p>	<p>The new paragraph 8.2 was proposed by the PT: “In general damage stability calculations should be performed for both ship sides. However, the damage stability calculation for one side of the ship may be accepted for symmetrical load (alternate, homogeneous, full, partial or empty), if the ship and all openings are also symmetrical and initial heel to portside or starboard is zero.</p>
<p>3.15. In relation to section 8.2, particular attention should be paid to the size and type of vessel under consideration when a loading program approval is being undertaken. Any vessel which is likely to undertake parcel operations and for which there is no evidence that it shall operate on a fixed cargo operation on long term contract should not be considered for fitment of an approved loading program only capable of undertaking damage calculations on one side of the vessel.</p>	<p>See the remark to the comment 3.14.</p>
<p>3.16. It is note that the methodology for considering the flooding of cargo and other tanks shall result in multiple free surfaces, and that these may have a significant effect on residual GZ where damaged compartments lie one above the other.</p> <p>Although we do not see any prohibition to this approach it is not in line with other IMO instruments and the effects of multiple free surface could be reduced if consideration were given to increasing the rate of flooding applied to tanks which lie wholly below the initial waterline. By flooding double bottom tanks in the first stage for example.</p>	<p>PT agreed to keep the text as it is because the requirement of IMO instruments referred by MCA seem to be applicable to the SOLAS probabilistic damage regulations.</p>
<p>3.17. We would exercise a note of caution in relation to the fitment of watertight means of closures to downflooding points. Where a closure is fitted to an underdeck escape it</p>	<p>It was agreed to amend the text of paragraph 10.1 as follows:</p>

must remain clear of the residual waterline irrespective of the means of closure. Fitment of a watertight closure is not a satisfactory means to address permanent immersion of such openings.

In addition, where escapes are fitted with weathertight means of closure particular attention should be paid to the residual freeboard and range to such openings as it may be necessary to return to them to ensure closure if left open after use, and they present a major downflooding risk in the open position in comparison with other progressive flooding points.

“The mandatory instruments referenced in paragraph 2.1 require the final waterline, taking into account sinkage, heel and trim, shall be below the lower edge of any opening through which progressive flooding may take place. Such openings shall include air-pipes (irrespective of closing devices) and those which are closed by means of weathertight doors or hatch covers and may exclude those openings closed by means of watertight manhole covers and flush scuttles, small watertight cargo tank hatch covers which maintain the high integrity of the deck, remotely operated watertight sliding doors, and sidescuttles of the non-opening type.

Within the required range of residual stability, the immersion of any of the openings listed above and other openings capable of being closed weathertight may be permitted.

~~ICLL Protocol 88 permits, in the case of doors separating a main machinery space from a steering gear compartment, watertight doors may be of a hinged, quick acting type kept closed at sea whilst not in use, provided also that the lower sill of such doors is above the summer load waterline.~~

In the final equilibrium condition watertight escape hatches should not be submerged below the equilibrium damage waterline and should be treated as weathertight openings⁴⁾.

Footnote:

4) This specification applies only to the escapes from spaces other than tanks.

For emergency generator room the lowest point of the room should remain above the final equilibrium damage waterline. Any opening leading to this room should be treated as unprotected or weathertight, as applicable.

~~The following exceptions may be permitted as per IACS UI SC156, unless indicated otherwise by the Administration principles apply:~~

i) Watertight doors under the final waterline after flooding

All watertight doors under the final waterline after flooding should be remotely operated sliding watertight doors. Installation of a hinged watertight door (e.g. between the steering gear compartment and engine room) is subject to acceptance by the Administration
~~Doors under the final waterline after flooding should be remotely operated sliding watertight doors with an exception to doors separating a main machinery space from a steering gear compartment. Hinged watertight doors may be acceptable as an alternative subject to lower frequency of passage through the doors, agreement by flag administration concerned and other additional requirements.~~

ii) Progressive flooding due to damage or submersion of air pipes

Progressive flooding may be accepted subject to the air pipes leading to relatively small compartments which are progressively flooded in a predictable and sequential manner in which all intermediate stages of flooding

	<p>(with the exception on no progressive flooding) and the final stage of flooding meet the required stability criteria.</p> <p>iii) Watertight doors on the aft wall of forecastle under the final waterline after flooding</p> <p>Hinged watertight doors at the aft bulkhead of a forecastle space are permitted to be submerged after damage only when possible progressive flooding is limited to one relatively small compartment which is progressively flooded in a predictable and sequential manner in which all intermediate stages of flooding (with the exception of no progressive flooding) and the final stage of flooding meet the required stability criteria. No further progressive flooding is permitted beyond the initial flooding of the forecastle. This approach is only permitted after all other options, such as increasing the sill height, relocating the door, only providing access from above, have been shown to be unworkable in practice.”</p>
<p>4. Guidance on application to existing ships</p>	<p>PT confirms that Rec. 110 should be applied to new ships only, but not to all new stability programs (see the application note of IACS UR L5. So, this issue may be raised under the topic “Maintenance of IACS Resolutions – UR L5”). PT agreed that the development of Guidance on the application to existing ships should be carried out be IMO based on the MCA comments and Paris MOU CIC results.</p>
<p>4.1. It is appreciated that IACS are providing this guidance for application on new vessels, constructed after it is adopted. We would question whether the standard applies to new</p>	

<p>ships only or to all new stability or loading program approvals made after this date, including those made for existing ships, and this interpretation would certainly assist any enforcement action taken on existing vessels.</p> <p>Given that enforcement shall take place, certainly within Paris MoU and/or EC areas, what we are trying to avoid is the prospect that new software provided to show compliance can be approved to previous standards not covered by this guidance and be seen to be ineffectual.</p>	
<p>4.2. Given our position at 4.1 above, we would consider it beneficial if the guidance could be expanded to indicate the application dates and criteria for compliance with Marpol Annex 1, IBC and IGC Codes and for additional aspects of damage stability such as the bottom raking damage now applied to some Marpol Annex 1 vessels. This information is essential in the approval of loading programs for existing vessels.</p>	
<p>4.3. In terms of enforcement action, we are not seeking any changes to existing international instruments. Consequently there shall be no retrospective changes to legislation, or requirement to re-approve stability information or damage stability calculations or critical KG/GM data where this has previously been unsoundly approved.</p> <p>Consequently, existing approved stability information shall remain the primary means for demonstrating compliance on existing ships.</p> <p>Our position remains that the master must demonstrate compliance through one of the following options : Being loaded closely to an approved condition in the stability information; being otherwise loaded with on-board verification record vs critical KG/GM data; being otherwise loaded with on board verification record vs direct calculation by approved loading program; or being otherwise loaded with record of stability approval from the Administration or RO.</p> <p>In the event that a vessel is loaded closely to a condition from the approved stability information, and dependent upon the quality of the approval of such information, there is a possibility that the vessel would fail if considered against a new approval made to</p>	

the revised guidance proposed. Whilst this may be anomalous, it is an inevitable consequence of enforcement action and reflects the primacy of the approved stability information.

Where such a vessel is retrofitted with a new approved loading program, and this showed non-compliance in the above case, the vessel would be permitted to sail as it meets one of the basic criteria for acceptance under PSCI. However, the master would be warned that such a decision to sail may have considerable consequences for financial liability should a damage event occur.

In reality we would not see this scenario to be a realistic event and most operators would require all conditions to be fully checked using the latest software within their SMS. The SMS would be checked for this guidance and an instruction to take advantage of this anomaly would be duly noted as an effective SMS failure.

The same reasoning would apply to reliance on existing KG/GM data. These may continue in use although they may not be soundly based, but there is no proposal to enforce any re-approval, we are just seeking to restore practice to what is provided for within present certification and approvals.

IACS may have a view on these thoughts as there are ISM aspects.

4.4. In relation to certification of tank vessels, it would be the intention of MCA to ensure that Marpol vessels carry a note in their approved stability information that the master must load closely to one of the approved loading conditions OR to load to another condition provided that this was i) checked for compliance with intact and damage stability by use of critical KG/GM data, and a verifiable record kept on board for inspection/audit purposes, or ii) checked for compliance with intact and damaged stability by direct calculation using an RO approved loading program, and a verifiable record kept on board for inspection/audit purposes. With i) or ii) applied as appropriate.

In either case, the verifiable records of other loading conditions which had been duly checked for compliance would be considered as additional approved conditions, and an

<p>extension to the approved stability information, and would need to be retained for 3 years to ensure availability during ISM audits.</p> <p>We would consider that for IBC and IGC ships, a similar note would be added as a schedule to the CoF by completing clause 5.2 in place of 5.1 and limiting carriage to “Conditions of loading close to one of the approved conditions in the stability information approved on or other loading conditions provided etc etc “.</p>	
<p>Annex A – Procedure for replacement of initial tank filling by sea water</p>	<p>This method is already included into Annex 5 of Rec.110 (see our remarks to comments 2.9 and 2.10).</p>
<p>When considering individual damaged compartments which have an initial filling level in the intact condition a transition must be made between this initial filling and the final stage, where any initial content has been fully substituted by sea water up to the level of the equilibrium waterline.</p> <p>Final filling levels of sea water may be determined from the lost buoyancy calculation used to determine the final equilibrium condition. Initial fillings may be determined from the input intact loading condition.</p> <p>In considering such a transition it is recognised that a single calculation method cannot simulate real time effects particular to all individual damage scenarios, such as whether the damage opening is large or small or high or low relative to the level of the initial content or the external sea level.</p> <p>However, calculations made in response to Marpol Annex 1 or the IBC and IGC Codes are all required to demonstrate how initial tank fillings are replaced by sea water, and any methodology proposed should be robust and have application to all tanks irrespective of their location or initial filling level.</p> <p>It is also apparent that any damage calculations made in respect of intermediate stages of</p>	

damage must be undertaken using a methodology which logically and consistently enables this transition to be accounted for.

The following text suggests such a methodology :

“In considering the transition between the initial filling of a tank subject to damage and its final filling at equilibrium, its contents during intermediate stages of damage should be determined in accordance with the following rules:

1. For each damaged compartment, the value of the mass of the final filling at equilibrium less the mass of the initial filling in the intact condition should be determined.
2. The total mass of the content of each damaged compartment at each of five intermediate stages of flooding and at final equilibrium should be determined by sequentially adding one sixth of this value to the mass of the initial filling for each stage.
3. Where the initial filling of a damaged compartment is not zero, the proportion of the initial mass remaining at each of the five intermediate stages of flooding should be determined by reducing the initial mass by one sixth at each stage. The remaining proportion of the initial filling assumed to remain in the final stage shall be zero.
4. The residual mass at each intermediate stage (determined by subtracting the remaining initial mass from the total mass at each stage) should be assumed to comprise sea water.
5. The total volume and effective SG to be applied to each damaged compartment during each intermediate stage should then be determined from the proportions of initial content and seawater, as shown in the examples below.

Initial filling = 540 tonnes at SG=1.800

Final filling at equilibrium = 240 tonnes at SG 1.025

Stage	Assumed total mass in compartment	Assumed mass at original SG	Assumed Mass of sea water	Total volume assumed in compartment	Effective SG assumed in compartment
0	540	540	0	300.0	1.800
1	490	450	40	289.0	1.695
2	440	360	80	278.0	1.583
3	390	270	120	267.1	1.460
4	340	180	160	256.1	1.328
5	290	90	200	245.1	1.183
6	240	0	240	234.1	1.025

Initial filling = 150 tonnes at SG=0.600

Final filling at equilibrium = 300 tonnes at SG 1.025

Stage	Assumed total mass in compartment	Assumed mass at original SG	Assumed mass of sea water	Total volume assumed in compartment	Effective SG assumed in compartment
0	150	150	0	250.0	0.600
1	175	125	50	257.1	0.681
2	200	100	100	264.2	0.757
3	225	75	150	271.3	0.829
4	250	50	200	278.4	0.898
5	275	25	250	285.8	0.962
6	300	0	300	292.7	1.025

“

IACS Rec. 110 - proposed revisions by GL

1. Expression “Oil TANKER”

The expression “Oil Tanker” as defined in the 2008 code on intact stability (MSC. 267(85)) includes the ship types “combination carrier” and “oil-chemical tanker”:

*Oil tanker means a ship constructed or adapted primarily to carry oil in bulk in its cargo spaces and **includes combination carriers** and any chemical tanker as defined in Annex II of the MARPOL Convention when it is carrying a cargo or part cargo of oil in bulk.*

As it was explicitly agreed by the Project Team dealing with Rec. 110 not to address combination carriers, there are several possibilities to solve this problem:

a) Adding a footnote to the title of Rec. 110: “**Guideline for Scope of Damage Stability Verification on new oil tankers, chemical tankers and gas carriers**” *)

*) excluding combination carriers

b) Indicating clearly in paragraph 1 “Application” that the Recommendation should not be applied to combination carriers.

c) Renaming “oil tankers” to “crude oil tankers”.

d) Implementing the vessel type “combination carrier” to IACS Rec. 110. This would extend the present scope into the direction of bulk carriers (carriage of deck load (UILL65) with SOLAS damage stability requirements).

Option a) was agreed by PT.

2. Tropical Freeboard

The following draught requirements for damage stability of tankers can be found in the various regulations:

a) ICLL Reg. 27 (11) requires “its summer load line”.

Damage Stability Calculation up to the draught at tropical Freeboard should not be taken into account at this stage. Instead, the PM is requested to consult with the GL PT Member as to whether clarification on the extent of the term “all anticipated conditions of loading” as contained in IGC & IBC Codes can be sought from

<p>b) MARPOL (Reg. 28) requires “any operating draught”.</p> <p>c) IBC+IGC Code 2.2+2.4 require “all anticipated conditions of loading and variations in draught and trim”.</p> <p>To show the requirement for damage stability verification up to a draught corresponding to tropical freeboard, if assigned, a paragraph like the following could be added to Rec. 110 paragraph 3.2 “Scope of stability verification”:</p> <p><i>“If tropical freeboard is assigned to an oil tanker, chemical tanker or gas carrier the verification of intact and damage stability should cover a draught range up to a draught corresponding to the tropical freeboard.</i></p> <p><i>Damage stability requirements according to ICLL Reg. 27 shall remain unaffected; these should be verified up to the summer load line.”</i></p>	<p>the SLF S/C by a separate submission.</p>
<p>3. ICLL damage stability calculation</p> <p>A procedure for correct application of the ICLL damage stability calculations could be displayed in paragraph 6 of IACS Rec. 110 in the following way:</p> <p><i>“In case of application of ICLL damage stability requirements to a new oil tanker, chemical tanker or gas carrier a damage stability calculation according regulation 27 should be performed considering the following:</i></p> <p><i>a) Find worst possible VCG with trimmed/untrimmed loading condition acc. ICLL Reg. 27.</i></p> <p><i>b) Create untrimmed initial loading condition with the (above) worst possible VCG considering all compartments empty and perform the damage stability analysis.</i></p> <p><i>c) ICLL Reg. 27 damage stability criteria should not be applied to service loading conditions and need not to be checked by stability computers.”</i></p>	<p>The practical methods applied by Members will be further considered by the PT.</p>
<p><u>Paris MOU CIC on Tanker Damage Stability</u></p>	<p>PT agreed that the questionnaire is a good basis for development of the Guidelines on application to existing</p>

ships. The special training program for PSCOs referred in the Press Release should also be considered.

Recommendation No. 111

“PASSENGER SHIPS – Guidelines for preparation of Hull Structural Surveys”

Part A. Revision History

Version no.	Approval date	Implementation date when applicable
Rev.1 (June 2018)	30 June 2018	-
New (Feb 2010)	8 February 2010	-

• Rev.1 (June 2018)

.1 Origin of Change:

- Suggestion by IACS member

.2 Main Reason for Change:

One panel member noted that Rec.111 “PASSENGER SHIPS – Guidelines for preparation of Hull Structural Surveys” para. 3.6 for air pipes refers to UR Z22 “Survey Requirements for Automatic Air Pipe Heads”. However, UR Z22 was deleted on 1 July 2014 and the survey requirements were incorporated in UR Z7. Thus, the requirements of automatic air pipe heads for passenger ships at special survey shall be clarified by amending the Rec.111

.3 List of non-IACS Member Classification Societies contributing through the TC Forum and/or participating in IACS Working Group:

None

.4 History of Decisions Made:

The matter was discussed by the Survey Panel during the 26th survey panel meeting and further confirmed under task PSU17031. Panel members agreed to delete the UR Z22 reference in paragraph 3.6 of Rec.111.

.5 Other Resolutions Changes

None

.6 Dates:

Original Proposal: 14 September 2017, made by Survey Panel
 Panel Approval: 15 March 2018 (Ref: PSU17031)
 GPG Approval: 30 June 2018 (Ref: 18099_IGb)

- **New (Feb 2010)**

.1 Origin for Change:

- Request by non-IACS entity (*Marine Accident Investigation Branch (MAIB)*)

.2 Main Reason for Change:

This IACS Recommendation has been developed as a response to recommendations from the UK Marine Accident Investigation Branch – MAIB given in their Report No. 5/2008 “Report on the investigation of the heavy weather damage to the passenger cruise ship Pacific Star”.

.3 History of Decisions Made:

The recommendation has been established according to the Work specification given in Form A Rev.2.

In addition the draft document was amended by the Survey Panel at the September 2009 meeting.

During the development two external reviews have been carried out by Cruise Lines International Association - CLIA with the following comments received.

05 August 2009:

The CLIA Technical Committee did not have any areas of concern to add to the listing in your letter and offered no technical advice on the inspection or repair of these areas. We will of course be interested in reviewing any draft guidelines which IACS may prepare. I would hope that our members and/or the Cruise Ship Safety Forum (of which LR, DNV, RINA and GL are members) would be able to provide input to such a draft.

23 November 2009:

We have reviewed the document and discussed it with our Technical Committee. Overall, we find this to be very good guidance and have only a couple of small points as indicated below.

- *First, may we suggest that the cover, if it must have a cruise ship sketch on the cover, have a ship that is not identifiable by brand. Using a sketch clearly showing the Carnival Cruise Line unique funnel is, in our view, not appropriate as it appears to single out and vilify a specific brand. Irrespective of the operator on whose ship incident the guideline is based, a general guideline such as this should not identify these specifics.*
- *May we also suggest to change the wording “each ship” in section 3.2 to “each class of ship” taking into consideration that the design of each ship in the same class is likely to be the same.*
- *Finally, current section 3.2 (access and inspection planning): “It is recommended that an accessibility document is developed for each ship containing the relevant information for accessing the structures indicated in 3.3 to 3.10 below.”*

- *Also, some of the items that are to be included in the accessibility document refer to specific safety issues and access procedures without providing further details. This is somewhat ambiguous. CLIA would like to recommend that we include a reference in the accessibility document to the applicable safety procedures as noted in the operator's Safety Management System and remove any ambiguous wording.*

.4 Other Resolutions Changes

None

.5 Any dissenting views

None

.6 Dates:

Original Proposal: *17 December 2009, made by Survey Panel PT on Task 58*

Panel Approval: *27 January 2010*

GPG Approval: *8 February 2010 (Ref. 8558dIGm)*

Part B. Technical Background

List of Technical Background (TB) documents for Rec.111:

Annex 1. **TB for New (Feb 2010)**

See separate TB document in Annex 1.



Note: *There is no separate Technical Background (TB) document for Rev.1(June 2018).*

Technical Background for Rec. 111 NEW, Feb 2010*

1. Scope and objectives

1) Develop an IACS Recommendation dealing with guidelines regarding the preparation for hull surveys on passenger ships particularly addressing the following items:

- Accessibility to all parts of the ship's structure;
- Provision of information to the surveyors concerning the normal working level of the liquid contained in a tank, and any previous problems associated with the space to be surveyed.

2) Each Member Society to use the IACS Recommendation developed as per 1) above to issue instructions to their surveyors, as deemed appropriate.

2. Engineering background for technical basis and rationale

N.A.

3. Source/derivation of the proposed IACS Resolution

All members of the IACS Survey panel were asked to provide their experiences to serve as a basis for development of the Recommendation.

CLIA was also invited to give such input, but no input was received.

The Recommendation was established by the Project Team based on the aggregated input from the members and the experience of the societies participating in the project team. During the process the Recommendation was reviewed by the IACS Survey Panel and CLIA, and comments were incorporated in the document.

4. Summary of Changes intended for the revised Resolution:

N.A.

5. Points of discussions or possible discussions

N.A.

6. Attachments if any

N.A.

(* Survey Panel Task No. 58)

Recommendation No.113 “Expert Parties Engaged in Visual and/or Sampling Checks for Preparation of Inventory of Hazardous Materials”

Part A. Revision History

Version no.	Approval date	Implementation date when applicable
Rev.1 (Oct 2012)	02 October 2012	-
NEW (Aug 2010)	26 August 2010	-

• Rev.1 (Oct 2012)

.1 Origin for Change:

- Suggestion by IACS member

.2 Main Reason for Change:

To update Recommendation 113 with IMO Resolution MEPC.197 (62) adopted on 15 July 2011.

.3 List of non-IACS Member classification societies contributing through the TC Forum and/or participating in IACS Working Group:

None

.4 History of Decisions Made:

A Panel member proposed to amend the Rec.113 because Rec. 113 was produced in 2010 with the reference of IMO Resolution MEPC.179(59)- Guidelines for the Development of the Inventory of Hazardous Materials. This document was further replaced by Resolution MEPC.197 (62) .Survey Panel discussed and agreed to amend the text of Rec. 113 accordingly.

.5 Other Resolutions Changes

None

.6 Dates:

Original Proposal: *06 April 2012, made by Survey Panel*
 GPG Approval: *02 October 2012 (Ref: 12161_IGb)*

- **NEW (Aug 2010)**

.1 Origin for Change:

- Based on IMO Regulation (*Hong Kong International Convention for the Safe and Environmentally Sound Recycling of Ships, 2009 & Res. MEPC 179(59)*)

.2 Main Reason for Change:

Entry in to force of the Hong Kong Convention in future.

.3 List of non-IACS Member classification societies contributing through the TC Forum and/or participating in IACS Working Group:

None

.4 History of Decisions Made:

A panel member proposed an amendment to UR Z17 for Expert parties engaged in visual and/or sampling checks and testing for testing hazardous materials for the new Ship Recycling Convention. The Survey Panel decided instead to develop a new recommendation for Expert parties engaged in visual and/or sampling checks for preparation of Inventory of Hazardous Materials.

.5 Other Resolutions Changes

None

.6 Dates:

Original Proposal: *05 February 2010, made by Survey Panel*
GPG Approval: *26 August 2010 (Ref: 9662_IGg)*

Part B. Technical Background

List of Technical Background (TB) documents for Rec.113:

Annex 1. **TB for Original Resolution (Aug 2010)**

See separate TB document in Annex 1.



Note: There is no separate Technical Background (TB) document available for Rev. 1 (Oct 2012).

Technical Background for Rec.113 New, Aug 2010

1. Scope and objectives¹

To develop a new IACS Recommendation for 'Expert parties engaged in visual and/or sampling checks for preparation of Inventory of Hazardous Materials'.

The Hong Kong International Convention for the Safe and Environmentally Sound Recycling of Ships, 2009 was adopted on 19th May 2009.

A major requirement of the convention is that ships should have onboard an Inventory of Hazardous Materials (Regulation 5.1) and that this shall be verified by the administration or by any person or organisation authorised by the Administration. For existing ships, Regulation 5.2 requires that a plan shall be prepared describing the 'visual and/or sampling check' by which the Inventory of Hazardous Materials is developed.

The IMO Res. MEPC 179(59) provides recommendations for developing the Inventory of Hazardous Materials to assist compliance with regulation 5 of the Hong Kong Convention.

The objective was to develop draft guidelines intended for shipowners, when drawing upon expert assistance for the onboard visual and/or sampling check, including the use of services from laboratories carrying out testing of samples, which reflects the Hong Kong International Convention for the Safe and Environmentally Sound Recycling of Ships, 2009.

2. Engineering background for technical basis and rationale

It was foreseen that whilst IACS member societies would verify the inventory and attend onboard for that purpose, they would not sample onboard for hazardous materials, organise the testing of hazardous materials, or prepare the inventory, which would remain under Owner's responsibility.

However, shipowners in general are not experts enough to undertake such work and so would be expected to employ experts to do this work. Both owners and IACS member societies will need confidence that the subcontractor is competent to do this work. It was concluded that Survey Panel should not engage at this stage to mandatory minimum requirements going beyond what is required by the "Ship Recycling Convention" and its associated Guidelines but develop a draft IACS Recommendation for 'Expert parties engaged in visual and/or sampling checks for hazardous materials.'

3. Source/derivation of the proposed IACS Resolution

- The Hong Kong International Convention for the Safe and Environmentally Sound Recycling of Ships, 2009 (SR/CONF 45)
- IMO Res. MEPC.179(59)

4. Summary of Changes intended for the revised Resolution:

New recommendation developed.

5. Points of discussions or possible discussions

None

¹ Survey Panel Task 66

6. Attachments if any

None

Recommendation No.114

“Recommendation for operational testing, inspection and documentation of emergency shutdown valves for liquefied gas carriers”

Summary:

This is an existing document, giving guidelines on requirements of the IGC Code (MSC.5(48) as amended) relevant to the operational testing, inspection and documentation of ESD. The necessity of the revision was agreed by IACS members so as to align the Rec. with the revised IGC Code (MSC.370 (93)).

With respect to REC No. 114 (June 2010): *“Recommendation for the design, construction, operation and survey of emergency shut down valves and safe cargo sampling connections on liquefied gas carriers”*, the title is changed to: *“Recommendation for operational testing, inspection and documentation of emergency shutdown valves for liquefied gas carriers”* with subsequent changes to the scope & requirements to the Testing, Inspection & Documentation of the emergency shut down valves in the cargo system in line with the revised IGC Code (MSC. 370(93)).

Part A. Revision History

Version no.	Approval date	Implementation date when applicable
Rev.1 (Dec 2018)	21 December 2018	-
New (June 2010)	30 June 2010	-

- **Rev.1 (Dec 2018)**

.1 Origin of Change:

- Suggestion by IACS member

.2 Main Reason for Change:

In the light of the revised IGC Code (MSC.370(93)), GPG tasked IACS panel members to review the applicable UI's & REC's. It was noted that interpretation as provided in REC. No. 114 requires amendments as per the revised IGC Code (MSC.370(93)), it was proposed by the panel members that existing REC. No.114 is to be revised.

.3 List of non-IACS Member Classification Societies contributing through the TC Forum and/or participating in IACS Working Group:

None

.4 History of Decisions Made:

This task was triggered by the Machinery Panel during 22nd meeting under PM5901-Maintenance of IACS resolutions.

The Machinery Panel have been requested by GPG to review applicable URs, UIs and RECs under their responsibility as the text in the original IGC code has been revised and the new IGC code has been adopted (Resolution MSC. 370(93) and where necessary propose revision, deletion or amendment of the application statements, taking into account that GPG is in favour of the retention of UR/UI's relating to the older IGC Code.

.5 Other Resolutions Changes

- UI GC2
- UI GC9
- UI SC6
- REC.85

.6 Dates:

Original Proposal: September 2015 (22nd Machinery Panel Meeting)

Panel Approval: 29 November 2018 (Ref: PM5901fIMn)

GPG Approval: 21 December 2018 (Ref: 15042_IGze)

• New (June 2010)

.1 Origin of Change:

- Request by non-IACS entity (*UK Marine Accident Investigation Branch (MAIB)*)

.2 Main Reason for Change:

Following a major leak of liquid propane which occurred alongside a Marine Terminal in the UK after an accident occurred when sampling the cargo, the MAIB investigated and made some Recommendations (MAIB Report No. 10/2007).

.3 List of non-IACS Member classification societies contributing through the TC Forum and/or participating in IACS Working Group:

None.

.4 History of Decisions Made:

Following the recommendations from MAIB, the IACS GPG tasked the Machinery Panel to review the case and develop requirements if felt necessary. The Machinery Panel developed a new Recommendation which was reviewed by the Survey Panel.

.5 Other Resolutions Changes:

None.

.6 Dates:

Original Proposal: February 2008, made by Machinery Panel

Panel submission to GPG: 19 May 2010 (Ref: 7588_PMa)

GPG Approval: 30 June 2010 (Ref: 7588_IGe)

Part B. Technical Background

List of Technical Background (TB) documents for Rec.114:

Annex 1. **TB for New (June 2010)**

See separate TB document in Annex 1.

Annex 2. **TB for Rev.1 (Dec 2018)**

See separate TB document in Annex 2.

Technical Background for Rec.114, New June 2010

1. Scope and objectives

On 17 October 2006, a major leak of liquid propane occurred alongside at the Fawley Marine Terminal in the UK after an accident occurred when sampling the cargo. The MAIB completed a full investigation and provided some recommendations. The IACS GPG tasked the Machinery Panel to evaluate the recommendations and to take appropriate action.

The MAIB recommendations were:

- 1) A proposal to IACS on the development of unified requirements (URs) on sampling arrangements for liquefied gas carriers. The standards should, as a minimum, address the relevant shortfalls identified in this investigation, especially with regard to the provision of two valve separation from the cargo system and the avoidance of screw couplings.
- 2) A proposal to IACS regarding the operation and design of ESD valves which:
 - Stipulates a requirement for ESD valves to be tested and inspected during class surveys to verify effective closure.
 - Ensures that the IGC Code requirement for local manual closure means the ESD valve can be positively closed by hand.
 - Requires arrangements for the indication of the status of ESD valves to accurately mimic whether the valve is open or closed.

2. Engineering background for technical basis and rationale

The accident happened while cargo sampling operations were being carried out by a cargo surveyor using a sampling cylinder connecting to the sampling point. The sampling point was a drain plug fitted on the bottom of a globe valve in series with an Emergency Shut Down (ESD) valve which was located on the cargo pump discharge line of No.2 cargo tank.

When the cargo surveyor turned the sampling connector, the sampling valve assembly fitted on the bottom of the globe valve came off in his hand, and cargo began to leak. He tried to refit the sampling valve assembly, but failed. Although the ESD valve which was in series with the globe valve was activated, it did not completely shut and therefore failed to stop the flow of gas. After several attempts to stop the leak over a 29-hour period, the leak was eventually stopped with the resultant loss of 66 tonnes of gas to the atmosphere. Examination of all ESD valves on board was carried out, the failed ESD valve was found to have internal damage which prevented its operation whilst all the others were found to be in working order.

(Additional details: MAIB Report No. 10/2007, May 2007)

3. Source/derivation of the proposed IACS Resolution(s)

The IGC code Regulation 5.6 specifies the requirements for cargo system valve arrangements and Regulation 9.1 the requirement for gas sampling points. The recommendations provided by the MAIB report are to provide more clarity to the requirements stipulated.

4. Summary of Changes intended for the revised Resolution(s):

N/A

5. Points of discussions or possible discussions

It should be noted that the sampling method used was not an approved one in that the sample point in this case was a globe valve drain connection and that no other vessel had suffered the same fate. However, recognising that the IGC code allows for threaded connections for the sampling connection for pipes with a diameter of 25mm or less, the possibility exists for this connector becoming unintentionally detached with the potential to leak gas and/or injure personnel.

The additional recommendations proposed by the MAIB were intending to further enhance the reliability of the ESD operation due to the lessons learnt. Since there have not been wide spread reports of ESD valve failures, the Panel concluded that a Unified Requirement would be excessive since it would force the changing of all ESD valves currently in use.

The Machinery Panel concluded that an IACS Recommendation would be appropriate and sufficient.

6. Attachments if any

N/A

Technical Background (TB) document for Rec 114 (Rev.1 Dec 2018)

1. Scope and objectives

Rec. No. 114 Reference is made to IGC Code Reg. 5.6, 9.1 and 18.7 changed to 18.10.5 and 18.6.2 of the revised IGC Code.

2. Engineering background for technical basis and rationale

1. The recommendation in accordance to the IGC Code requiring the ship staff involved in the cargo operation to have sufficient information about the cargo properties & operation of the cargo system.
2. In order to meet the above requirements, the cargo handling controls & alarms needs to be tested prior each cargo transfer operation.
3. For Emergency Shut Down System, the cargo emergency shutdown & alarm system involved in Cargo transfer operation shall be checked & tested prior beginning of Cargo handling operation.
4. Hence the Ship operators should periodically verify that the ESD valves onboard their vessels function correctly. The test should be recorded.
5. Also, as part of the check on the integrity of the cargo containment system, the ESD valves should be pressure tested and internally inspected. Pressure testing at the same pressure as working pressure is recommended to be conducted every 5 years.
6. As for the documentation The instruction manual produced by the ESD valve manufacturer providing information on installing, servicing and reassembly of the valves should be retained on board the ship.

3. Source/derivation of the proposed IACS Resolution

Rec. 114 Reference is made to IGC Code as per (MSC. 5(48)) Reg. 5.6, 9.1 and 18.7 changed to 18.10.5 and 18.6.2 of the revised IGC Code (MSC. 370(93)).

4. Summary of Changes intended for the revised Resolution:

1. The heading of the Recommendation changed to "Recommendation for operational testing, inspection and documentation of emergency shutdown valves for liquefied gas carriers".
2. The reference is made to IGC Code paragraph 18.10.5 & paragraph 18.6.2 of the (MSC. 370(93))
3. For the scope the document provides the guidelines for the operational testing, Inspection and documentation for ESD valves for vessel under IGC Code.
4. Ship operators should periodically verify that the ESD valves onboard their vessels function correctly. The test should be recorded.

5. Also, as part of the check on the integrity of the cargo containment system, the ESD valves should be pressure tested and internally inspected. Pressure testing at the same pressure as working pressure is recommended to be conducted every 5 years.
6. As for the documentation The instruction manual produced by the ESD valve manufacturer providing information on installing, servicing and reassembly of the valves should be retained on board the ship.

5. Points of discussions or possible discussions

None

6. Attachments if any

None

Recommendation No.116 “Performance Standard for Protective Coatings for Cargo Oil Tanks of Crude Oil Tankers - 5 years field exposure test in accordance with MSC.288 (87)”

Summary

Recommendation 116 is deleted as all recommendations are considered by UI SC 259 (Corr.1 Oct. 2014)

Part A. Revision History

Version no.	Approval date	Implementation date when applicable
Del (Sept 2023)	29 September 2023	-
Rev.1 (Feb 2013)	14 February 2013	-
New (Feb 2011)	16 February 2011	-

- **Del (Sep 2023)**

1 Origin of Change:

- Based on IACS Requirement (Periodic review of IACS Resolutions)

2 Main Reason for Change:

UI SC 259 (Corr.1 Oct. 2014) considers all recommendations.

3 List of non-IACS Member classification societies contributing or participating in IACS Working Group:

None

4 History of Decisions Made:

Discussed by correspondence in the Safety Panel.

5 Other Resolutions Changes:

N/A

6 Any hinderance to MASS, including any other new technologies:

None

7. Dates:

Panel Approval : 23 August 2023 (Ref: PS23036fISb)
GPG Approval : 29 September 2023 (Ref: 22183dIGb)

• Rev.1 (Feb 2013)

1 Origin of Change:

- Suggestion by IACS members

2 Main Reason for Change:

To harmonise the recommendation with the requirements in MSC.288 (87).

3 List of non-IACS Member classification societies contributing or participating in IACS Working Group:

None

4 History of Decisions Made:

Statutory panel developed a new UI 259 for PSPC-COT – IMO resolution MSC.288(87). It was suggested that Rec 116 also needs to be revised to harmonise it with IMO resolution MSC.288(87).

5 Other Resolutions Changes:

New UI SC259

6 Dates:

Original Proposal : 12 January 2013 (Made by: Statutory panel)
GPG Approval : 14 February 2013 (Ref: 9638fIGi)

• New (Feb 2011)

1 Origin of Change:

- Based on IMO Regulation (MSC.288 (87))

2 Main Reason for Change:

Imminent need for paint industry to produce approved by 5 year filed exposure test prior to the statutory entry into force of the resolution (1 January 2012), while requirements will be mandatory on 1 January 2013.

3 List of non-IACS Member classification societies contributing or participating in IACS Working Group:

None

4 History of Decisions Made:

Procedures for the approval of coating system is provided as "Method B" in PR 34 and UI SC 223.

Pending the formal conclusion of the relevant Unified Interpretation, this part has been developed as a Recommendation to provide an interim solution.

5 Other Resolutions Changes:

Under development

6 Dates:

Original Proposal	: 30 September 2010	(Made by: EG Coating)
GPG Approval	: 16 February 2011	(Ref: 9638dIGc)

Part B. Technical Background

List of Technical Background (TB) documents for Rec.116:

Annex 1. **TB for Original Resolution (Feb 2011)**

See separate TB document in Annex 1.

Note: There is no separate Technical Background (TB) document available for Rev.1 (Feb 2013), Del (Sep 2023).

Technical Background for Rec.116 New, Feb 2011

1. Scope and objectives

To provide a clear test method for the "5 year field exposure test".

2. Engineering background for technical basis and rationale

Some owner/paint manufacturer have already started field exposure test. In order to provide a procedure for the test, using the established test procedure given as "Method B" in the PR 34 and UI SC 234, as a basis of the work, taking into account the unique elements given in MSC.288 (87) for cargo oil tanks of crude oil tankers, a new recommendation has been prepared.

3. Source/derivation of the proposed IACS Resolution

IACS PR 34 and UI SC 234, as well as IMO MSC.288 (87).

4. Summary of Changes intended for the revised Resolution:

New recommendation developed to meet the requirements of MSC.288 (87).

5. Points of discussions or possible discussions

1. With regard to the test reporting format, the Group noted that Recommendation 87 is no longer available to the public, as well as the fact that the reporting format given in Annex to Recommendation requires modification for the use of field exposure test as per MSC.288 (87), the Group inserted a phrase "in accordance with the principles in section 4 of MSC.1/Circ. 1330" at this stage as an interim solution.
2. Paragraph 2.3 was developed, taking into account the footnotes inserted for the alternative coating system given in MSC.288 (87).

6. Attachments if any

None

Recommendation No.117 “Exchange of Statutory Documentation upon Transfer of Class”

Summary

This revision is to add a document in the list of Exchange of Statutory Documentation upon Transfer of Class.

Part A. Revision History

Version no.	Approval date	Implementation date when applicable
Rev.2 (May 2020)	12 May 2020	-
Rev.1 (Oct 2019)	16 October 2019	-
NEW (Mar 2011)	09 March 2011	-

• Rev. 2 (May 2020)

.1 Origin for Change:

- Suggestion by IACS member

.2 Main Reason for Change:

As proposed by one member, Survey Panel agreed to discuss regarding internal procedure of reporting EEDI data of TOC vessels under Reg.21.6 of MARPOL Annex VI and periodical monitoring, which requires the EEDI data from July to December in the previous year and the data from January and June to be reported to IMO by the end of January and July respectively, in order to avoid any data missing for TOC vessels, in particular for the vessels which transferred its class soon after the delivery.

.3 List of non-IACS Member classification societies contributing through the TC Forum and/or participating in IACS Working Group:

None

.4 History of Decisions Made:

Survey Panel discussed and agreed that the EEDI data is to be reported by the society who issued the first International Energy Efficiency Certificate to avoid any EEDI Data missing. And Survey Panel also concurred with the view that Rec 117 is to be revised with addition of the approved EEDI Technical File, since it is a statutory document.

No TB is expected for this revision.

.5 Other Resolutions Changes:

None

.6 Any hinderance to MASS, including any other new technologies:

None

.7 Dates:

Original Proposal: 17 March 2020 (proposed by one)

Panel Approval: 2 April 2020 (Ref: PSU20014)

GPG Approval: 12 May 2020 (Ref: 20060_IGc)

• Rev. 1 (Oct 2019)

.1 Origin for Change:

Suggestion by IACS member

.2 Main Reason for Change:

As proposed by one member, Survey Panel agreed to consider the elimination of the administrative burden occurring, in the process of transfer of/adding class, due to the issuance and management of invoices associated with the provision, by the losing/first Society to the gaining/second Society, of the documentation foreseen by PR1A, PR1B and REC.117.

.3 List of non-IACS Member classification societies contributing through the TC Forum and/or participating in IACS Working Group:

None

.4 History of Decisions Made:

Survey Panel Members reviewed Rec. 117, and agreed to revise this document with the deletion of paragraph 3 about TOC charges between Losing Society and Gaining Society.

Survey Panel members concurred with the view that these are financial topics and purely administrative matters, therefore these should be left to each individual Society rather than be ruled by IACS.

No TB is expected for this revision.

.5 Other Resolutions Changes:

None

.6 Any hinderance to MASS, including any other new technologies:

None

.7 Dates:

Original Proposal: 22 February 2019 proposed by one Member
Panel Approval: 21 September 2019 (PSU19009)
GPG Approval: 16 October 2019 (19182_IGb)

• **New (March 2011)**

.1 Origin for Change:

- Suggestion by an IACS member

.2 Main Reason for Change:

To convert the contents of Internal Information No.5 into an IACS Recommendation as it was decided to delete Internal Information No.5.

.3 List of non-IACS Member classification societies contributing through the TC Forum and/or participating in IACS Working Group:

None

.4 History of Decisions Made:

GPG decided to delete the category 'Internal Information' and review the contents of Internal Information documents for appropriate relocation (GPG 67 FUA 8). A member proposed to convert the contents of Internal Information No.5 into an IACS Recommendation. Permsec prepared the draft of new Recommendation and circulated it for GPG's review and final approval. Rec. 117 was approved by GPG after discussions with some amendments.

.5 Other Resolutions Changes

PR 1, PR 8, II 5, II 12.

.6 Dates:

Original Proposal: *15 October 2010 by an IACS Member*
GPG Approval: *09 March 2011 (Ref: 10115_IGf)*

Part B. Technical Background

List of Technical Background (TB) documents for Rec.117:

There is no separate technical background document available for Rec 117 (New, March 2011), Rev.1 (Oct 2019) and Rev.2(May 2020).



Recommendation No.118 “Maritime Labour Convention, 2006: Handling of Seafarer Complaints by Recognized Organizations”

Summary

Recommendation 118 was deleted on 15 June 2019 as the text was incorporated into Recommendation 129 (Rev.1 June 2019)

Part A. Revision History

Version no.	Approval date	Implementation date when applicable
Deleted (June 2019)	15 June 2019	-
Rev.1 (Jan 2012)	20 January 2012	-
NEW (Feb 2011)	25 February 2011	-

- **Deleted (June 2019)**

Recommendation 118 was deleted on 15 June 2019 as the text was incorporated into Recommendation 129 (Rev.1 June 2019)

- **Rev.1 (Jan 2012)**

.1 Origin for Change:

- Suggestion by IACS members

.2 Main Reason for Change:

Recommendation No.118 was amended in light of comments received from ISF.

.3 List of non-IACS Member classification societies contributing through the TC Forum and/or participating in IACS Working Group:

None

.4 History of Decisions Made:

A meeting between IACS and ISF was held in April 2011 at which Rec. 118, which had been published in Feb. 2011, was introduced. After the meeting, IACS received a letter from ISF in July 2011 with comments and suggestions on Rec. 118. At GPG's instruction, IACS sent a reply to ISF responding to ISF's concerns in Sept. 2011 and advised that IACS would uptake to improve the wording in Rec.118.

.5 Other Resolutions Changes

None

.6 Dates:

Original Proposal: 5 December 2011, made by EG/ILO
GPG Approval: 20 January 2012 (Ref. 11125_IGj)

• **NEW (Feb 2011)**

.1 Origin for Change:

Suggestion by IACS PermSec, in consultation with EG/ILO

.2 Main Reason for Change:

EG/ILO requested that IACS position on the handling of complaints is to be codified and published as a Recommendation for use in the upcoming discussions with flag Administrations and stakeholders.

.3 List of non-IACS Member classification societies contributing through the TC Forum and/or participating in IACS Working Group:

None

.4 History of Decisions Made:

In its 2nd meeting in November 2010, EG/ILO developed a position paper "Handling of Complaints by Recognized Organizations" and submitted it for GPG approval. Following GPG approval of the paper on 20 January 2011, EG/ILO unanimously agreed to develop a recommendation based on the approved IACS position on this. IACS PermSec, in consultation with EG/ILO, prepared the draft of a new recommendation No. 118 and submitted for GPG approval. GPG approved the recommendation with some editorial corrections on 25 February 2011.

.5 Other Resolutions Changes

None

.6 Dates:

Original Proposal: 14 February 2011, made by IACS PermSec/EG/ILO
GPG Approval: 25 February 2011 (Ref: 9671cIGg)

Part B. Technical Background

List of Technical Background (TB) documents for Rec.118:

Annex 1. **TB for Original Resolution (Feb 2011)**

See separate TB document in Annex 1.



Annex 2. **TB for Rev.1 (Jan 2012)**

See separate TB document in Annex 2.



Technical Background for Rec.118 New, Feb 2011

1. Scope and objectives

A Recognized Organization (RO) may in some circumstances be specifically authorized by the flag State to carry out an inspection following a particular seafarer complaint. Also, when a vessel is inspected under the Maritime Labour Convention (MLC), 2006 by a RO on behalf of the flag State, a seafarer or seafarer representative may contact the RO to register a seafarer complaint. The complaint may be in verbal or written form. This recommendation describes the measures a RO should take subsequent to receiving a complaint from a seafarer.

2. Engineering background for technical basis and rationale

The rationale of this recommendation is that ROs should concern themselves only with matters of regulatory compliance that can be substantiated by objective evidence. This includes verifying the existence and satisfactory operation of Onboard Complaints Procedures in accordance with the flag State's national requirements implementing the MLC. ROs should not discuss or attempt to resolve allegations of harassment, victimization and other complex matters or personal disputes. These should be passed to the flag State for resolution, but only when the complainant has put them in writing.

3. Source/derivation of the proposed IACS Resolution

The Maritime Labour Convention, 2006, Regulation 5.1.5 and Guidelines for flag State Inspections, Para 63.

4. Summary of Changes intended for the revised Resolution:

New recommendation developed.

5. Points of discussions or possible discussions

None

6. Attachments if any

None

Technical Background for Rec.118 Rev.1, Jan 2012

1. Scope and objectives

Amend IACS Rec. 118 to:

- Clarify the wording that a written complaint provided by the seafarer should be attached to the copy of the report submitted to the flag State.

2. Engineering background for technical basis and rationale

None

3. Source/derivation of the proposed IACS Resolution

The Maritime Labour Convention, 2006, Regulation 5.1.5 and Guidelines for flag State Inspections, Para 63.

4. Summary of Changes intended for the revised Resolution:

A written complaint provided by a seafarer will not be included in/with the inspection report provided to the Master or Shipowner. The written complaint will only be attached to the report to the flag State in order to maintain complainant confidentiality.

5. Points of discussions or possible discussions

None

6. Attachments if any

None

Recommendation No.119 "Uniform application of SOLAS Reg. II-1/3-9 in association with MSC.1/Circ.1331"

Part A. Revision History

Version no.	Approval date	Implementation date when applicable
Rev.1 (Apr 2013)	22 April 2013	-
New (May 2011)	12 May 2011	-

• Rev.1 (Apr 2013)

.1 Origin for Change:

- Suggestion by IACS Statutory Panel

.2 Main Reason for Change:

MSC.1/Circ.1331 requires, in paragraphs 3.6.3 (Initial Installation Test), that every new accommodation ladder should be subjected to a static load test of the specified maximum working load upon initial installation. Unlike the periodical, renewal and annual surveys addressed in paragraph 5, paragraphs 3.6.3 does not mention that the accommodation ladder is to have no permanent deformation or damage for satisfactory completion of the initial survey. IACS considers that this is because there should be no failed structural components for new approved accommodation ladders. Accordingly, REC.119 is revised to remove the criteria for permanent deflection to be recorded during the initial survey. However, the maximum working load should still be applied after installation to confirm that the accommodation ladder including the winch and the connection to the deck is adequate.

Also, REC.119 is editorially revised by replacing "suspending" with "holding" in the phrase in the 1st row of the matrix so as to be consistent with the same phrase occurring in the 3rd row of the matrix and with the use of "holding" in ISO 7364.

.3 List of non-IACS Member classification societies contributing through the TC Forum and/or participating in IACS Working Group:

None

.4 History of Decisions Made:

The revision of the recommendation and the justification (given above in section "Main reasons of change") were unanimously agreed by all Statutory Panel Members.

GPG approved the revision to the recommendation.

PermSec updated the History File using the agreed justification.

.5 Other Resolutions Changes

None

.6 Dates:

Original Proposal: *06 March 2013 by Statutory Panel*

GPG Approval: *22 April 2013 (Ref: 13068_IGb)*

• New (May 2011)

.1 Origin for Change:

Suggestion by IACS Statutory Panel

.2 Main Reason for Change:

New IACS Recommendation developed by IACS Statutory Panel under the long-standing Task 4 - Interpretation of IMO instruments.

.3 List of non-IACS Member classification societies contributing through the TC Forum and/or participating in IACS Working Group:

None

.4 History of Decisions Made:

The draft recommendation was unanimously agreed by all Panel Members. HF&TB documents were not developed as based on the instructions of IACS Procedures, Vol.1, IACS Recommendation should not be treated as IACS Resolution.

GPG approved the recommendation with some editorial changes suggested by members.

PermSec developed a History File, to record the revision history.

.5 Other Resolutions Changes

None

.6 Dates:

Original Proposal: *20 April 2011 by Statutory Panel*

GPG Approval: *12 May 2011 (Ref: 11070_IGb)*

Part B. Technical Background

List of Technical Background (TB) documents for Rec.119:

No Technical Background documents were developed for Rec.119 (New, May 2011) and Rev.1 (April 2013).



Recommendation No.120

“Survey of electrical equipment installed in hazardous areas on tankers”

Part A. Revision History

Version no.	Approval date	Implementation date when applicable
New (June, 2015)	04 June 2015	-

- **New (June 2015)**

.1 Origin for Change:

- Based on IMO Regulation (*Changes to SOLAS, IBC & IGC*)

.2 Main Reason for Change:

Changes to SOLAS, IBC and IGC which now reference the IEC Standard 60092-502: Electrical Installation in ships – Tankers – Special Features as the governing standard for electrical installations on Tankers. However, it was decided that a common approach to survey procedures of Ex installations should be provided as well as identifying surveyor training requirements.

.3 List of non-IACS Member Classification Societies contributing through the TC Forum and/or participating in IACS Working Group:

None

.4 History of Decisions Made:

The form A was approved 14 September 2006

.5 Other Resolutions Changes

None

.6 Dates:

Original Proposal: 13 October 2005 Made by: *Machinery Panel*
 Panel Approval: 14 May 2015
 GPG Approval: 04 June 2015 (Ref: 5029bIGm)

Part B. Technical Background

List of Technical Background (TB) documents:

Annex 1. **TB for New (June 2015)**

See separate TB document in Annex 1.



Technical Background (TB) document for Rec 120 (New, June 2015)

1. Scope and objectives

In December 2004 IMO's Maritime Safety Committee (MSC79) adopted amendments to the regulation of electrical installations on tankers. The substance of the amendments is that the revised regulations refer to IEC 60092-502:1999 as the governing standard for electrical installations on tankers. SOLAS December 2004 Amendments II-1/45, Paragraphs 10, 11 & 12 have been revised.

IBC code (International Code for the Construction and Equipment of ships carrying Dangerous Chemicals in Bulk) and IGC code (International Code for the Construction and Equipment of ships carrying Liquefied Gases in Bulk) have been updated, referring to IEC 60092-502 as the governing standard.

Applicable to: Oil carriers, Chemicals carriers and Gas carriers with keel laying date > 1. January 2007

The tasks were to develop a UR "Z" for survey procedures for Ex installations as well as identify surveyor training requirements in a separate document.

2. Engineering background for technical basis and rationale

A project team was formed consisting of two experienced electrical engineers and a member of the survey panel to bring experience of the surveying of Tankers and the application of IBC and IGC codes.

3. Source/derivation of the proposed IACS Resolution(s)

- SOLAS, IBC & IGC
- IEC 60092-502 and IEC 60079-17
- A.948(23), A789(19) & PR7 were used as a reference for surveyor training requirements

4. Summary of Changes intended for the revised Resolution(s)

N/A

5. Points of discussions or possible discussions

5.1. Points of discussion for "survey requirements":

- 1) Grounding of IS circuits have been discussed. Ref. IEC 60079-17 Ch. 5.3.
- 2) Termination of "spare cables". IEC 60079-14 Ch. 9.1.12 says multi core cables only. We have interpreted this as all spare cable in hazardous area.
- 3) Ref. Item 1. "Ambient temperature range for the equipment1)" with its note was subject to discussion.
- 4) We had discussion regarding IEC60079-17 Table 1 item A11. quote "The flange gap dimensions are within maximum values permitted" We concluded this is not possible to check during survey, thus this is not included.
- 5) PT recommendation for the form of created documents. We suggest for the document "surveyor training needs" it will be a Recommendation. The document

"Survey of electrical equipment installed in hazardous area on tankers" take the form as UR Z.

- 6) Requirement to maintenance history has been deleted.
- 7) The draft UR Z[xx] as prepared by the Project Team was considered by the Machinery Panel by correspondence and during the 6th Panel meeting, Sept. 2007. Comments received from were discussed and the following modifications to the PT draft agreed at the 6th Panel meeting:
 - a. Add under 6.2: "Be of a type designed to prevent spark and arcs and "hot spots" during its normal operation."
 - b. Modify under 5.2.3: "Ex-d. There is no significant corrosion and damage to the flame path ¹⁾."
 - 1) *Visual inspection only. If any damage or corrosion is detected inspection of the flame path is required.*
 - c. Renumber and rearrange paragraphs to enhance readability
4.12: Remove requirement for measuring number of air changes as this may be difficult to implement.
- 8) UR Z [xx] was agreed unanimously by Panel members. It was agreed to forward the draft text to the Survey Panel for review. The survey panel provided some minor text amendments and asked for the UR to be rearranged as follows:
 - 1 – Scope
 - 2 – Enclosures
 - 3 – Surveys on New buildings
Documentation for surveys
Survey of installation
 - 4 – Survey on existing ships

The survey panel did not like the use of statements such as "Detailed Survey" and proposed that the following should be used "survey by means of opening enclosures by appropriate tools and checking connections/conditions/function"

Also, the machinery panel were asked to consider whether text indicating what to look at i.e. typical problems such as cracks etc are usually not included within IACS URs. Such text is usually providing guidelines to the surveyor and is usually listed in IACS recommendations.

It also directed that the qualifications of the survey section be removed as this is not a mandatory requirement and is under the control of the individual classification societies and therefore the remit of the surveyors training should be included within a recommendation.

The survey panel only recommended one minor amendment to the Rec. xx on surveyor training needs in that specifying a relevant training course and practical training should be completed is very subjective and therefore should be removed.

- 9) The 12th Panel meeting recorded as follows:
The Chair recalled the history of the subject task. It was proposed to improve the layout of the current draft and one member volunteered to submit it to the Panel for comments. There were some editorial changes proposed which were included in

the draft and comments made during the meeting comments received by correspondence.

- 10) One member re-wrote the document in the new format with the changes proposed and submitted for comment.
- 11) Principal comments were given by 2011-04-15 as follows:
- Item 1.2 (Manufacturer's declaration), Column "Acceptance criteria", part "Note"
One member suggests to indicate examples of simple apparatus (thermocouples, photocells, junction boxes and etc.) for better understanding, as stated in IEC 60092-502 (item 6.5.2.b).
 - Item 3.4 (Cables)
Information that "Intrinsically safe cable and non-intrinsically safe cable are not laid in the same cable bunch or pipe" should be added in (please see item 3.2.8 of Consolidated Comments Version).
 - Item 1.2 -Manufacture Simple apparatus
Add the following Note to "How" for Item 2:
Note:
In cases where the required mark for "Test institute and certificate number" has not been marked on Ex equipment, evidence of class approval may be accepted instead.
 - Item 2.7 - Equipment condition
One member is of the opinion that the marking of an "R" after major repairs have been completed is only required by EN standards. Therefore, it is recommended to revise "Acceptance Criteria" for Item 2.7.
Major repairs like change of motor bearings, etc. shall be done by qualified personnel and marked with the symbol R if required and shall be recorded.
 - Item 3.5 - Gas tight cable penetrations
It is proposed to clarify the inspection methods for sealing of gas tight cable penetration by examples. (e.g. "NB : Air test" and "SIO : Visual examination")
 - Item 7 - Space protected by over-pressure
It is proposed that the followings are revised: "Acceptance Criteria" for Item 7 in accordance with regulation for "Areas protected by overpressure:" for Periodical Surveys.
Action upon loss of pressure can be automatic or manual disconnections and audible and visual alarms depending on type of Ex protection used. Alarms are to be given at a manned station.
 - 6. Surveys on ships in Operation
An insulation resistance measurement is required every year in current draft UR. One member would like to clarify whether the confirmation of an insulation resistance meter installed in a 440V or 100V switchboard is acceptable instead of such a measurement. Furthermore, it is believed that because a gas free condition is needed to measure the insulation resistance in oil tankers, it is impractical to perform such a measurement each year for such ships.
 - 7. Periodical Survey
It is not appropriate that the UR specifies the wording "Not all classification societies do accept them". Therefore, such wording should be removed from the last paragraph of "Periodical Surveys".
 - Item no.6
Add Ventilation failure has to be alarmed and Electric motors driving fans should be placed outside the airflow for such ventilation onboard chemical and gas tankers.

12) New comments by deadline 2011-05-12:

- Concerning Earthing and Bonding (item 4), a MAXIMUM value for bonding resistance should be established the maximum allowable resistance value for earthing and bonding should be very low, and I propose 1 milliOhm (1 mOhm).
[☑ Conclusion: 1 MΩ is according to E9.](#)
- Concerning Insulation Resistance (Item 4.2), a MINIMUM value for Insulation resistance should be established (as it was in the original document), and I agree with 1 MegaOhm (1MOhm)
[☑ Conclusion: Agreed](#)
- Further, we do not agree to include in the UR Z... the sentence added at item 6." Electric motors driving fans should be placed outside the air flow for such ventilation onboard chemical and gas tankers." because we consider it not technically correct and not aligned with current IEC standards; in case this sentence is introduced, one member will consider raising a reservation; one member opinion is that also IGC and IBC should be amended in this respect.
[☑ Conclusion: Propose to delete it as IACS is minimum requirements and those who require the fans to be outside of the ventilation duct have to add this in their own implementation.](#)
- 4.2 Insulation resistance of all electrical equipment should be minimum 1 MOhm. The insulation resistance is to be measured between operational conductive alive materials (conductors, contacts etc.) and operational conductive not alive materials (metal housings and cabinets) or ship's hull. This resistance is a value of the quality of the insulating materials, which should be as high as possible!
[☑ Conclusion: Agreed](#)
- In 2.9 add the word "proper" to read "A proper barrier is to be provided"
[☑ Conclusion: Propose the text: "A barrier/isolator is provided"](#)
[Reason: Both barriers and the isolators are interfaces between the sensor or the actuator in the Ex-i area and the controller.](#)
- In 3.4 replace "Intrinsically safe cable and non-intrinsically safe cable are not laid in the same cable bunch or pipe unless there is intermediate layer of insulating material or earthed metal partition and intrinsically safe circuits or non-intrinsically safe circuits have metal sheaths or screens" with "IS- and non-IS cables may be pulled in the same bundle or duct provided: There is intermediate layer of insulating material or earthed metal partition between the cables, and IS- or non-IS circuits have metal sheaths or screens."
[☑ Reply: Disagree, there is no difference in content of the text, but existing text is editorially improved.](#)

5.2. Comments returned from GPG:

1. With regard to the draft UR Z[xx]

1.1 We appreciate the efforts to propose a uniform implementation statement for the draft UR, since none was included; however, the statement proposed ("This UR is to be uniformly implemented by IACS Societies from [1 July 2012][1 January 2013].") may not be sufficient since, as the HF&TB indicates, the requirements in SOLAS, IBC Code

and IGC Code are applicable to oil carriers, chemical carriers and gas carriers with a keel laying date > 1 January 2007.

[Machinery Panel: Reflected under 1. Scope in the note.](#)

1.1.1 It appears that new building (NB) would be ships contracted for construction on/after [1 January 2013] and ships in operation (SIO) would be ships with a keel laying date on/after 1 January 2007. Is this what the Machinery Panel intends?

[Machinery Panel: Yes, reflected under 1. Scope in the note.](#)

1.2. The intent of the second paragraph of the scope ("Compliance with the international standard IEC 60079-17 Explosive atmospheres – Electrical installations inspection and maintenance arrangements that comply with this UR may be accepted by the classification society.") is not clear. It is understood that the intent is that equipment in compliance with IEC 60079-17 may be accepted as complying with the draft UR. If this is what the Machinery Panel intends, the sentence should be reworded accordingly.

[Machinery Panel: Agree, text deleted.](#)

1.3. For ships in operation (SIO), the surveys for which these items are to be checked should be indicated (i.e., special/renewal, intermediate, annual).

[Machinery Panel: Draft UR updated accordingly.](#)

1.3.1 We note that item 4 refers to "annual surveys" and to "major surveys." We presume that "major surveys" means intermediate and special surveys and request that this be clarified.

[Machinery Panel: The wording is identical to the wording used in UR E9, but as this is not in line with the correct terminology, the proposal is amended.](#)

2. With regard to the draft REC No.xx, editorial changes are proposed in the attached file.

[Machinery Panel: Noted and corrected.](#)

3. We need clarification for the following Note which is laid down in the Scope of URz:
Note: The society may require design assessment as part of the verification of some of the survey items

It seems that the Note has not been discussed in MP. What design assessment in above Note to be done?

[Machinery Panel: Text is found unclear and agreed to be deleted.](#)

4. Item 1.2

In column "How", the third bullet should be split in two and separated by an "or" rather than an "and", hence a new fourth bullet should read "or having enclosure of at least IP55 and acceptable surface temperature"

[Machinery Panel: Agreed and document updated.](#)

5. Item 3.4, column "Acceptance criteria":

5.1 The reference to an "intermediate layer of insulating material" should be removed. The safety objective of this criterion is to avoid electrical inductance between cables which can be achieved by providing an earthed metal partition, as also stated in this item, but not through an unspecified layer of insulating material.

[☑ Machinery Panel: Agree, text deleted.](#)

[The existing text was earlier added based on comment regarding making this in line with 12.2.2.5 of IEC 60079-14. However, the referred section in IEC concerns conductors, not cables. Text deleted.](#)

5.2 The reference to "intrinsically safe circuits or non-intrinsically safe circuits have metal sheaths or screens" should be removed. Metal sheathing or screens alone are not considered sufficient (see also IEC 60092-352 para. 3.15n).

[☑ Machinery Panel: Agree, text deleted.](#)

5.3. Circulation March 2012:

- 1) Added Ex-d and Ex-e to item 2.1.
- 2) Changed the note under scope to be specific on application.

5.4. Circulation June 2012:

- 1) Proposed to change the note 1 regarding temperature ratings for the equipment has been agreed.
- 2) A note new under 2.1 has been agreed.
- 3) A proposal to delete item 2.5 has not been agreed.

5.5. Circulation February 2015:

- 1) Survey Panel concluded that this IACS document should be an IACS Recommendation instead of UR.
- 2) Survey Panel was of the opinion that any IACS document (Recommendation) will not be necessary for training of Surveyors. Therefore, Panel did not agree with the draft new Rec. XX (Surveyor training needs for surveys of electrical installations in hazardous area) which was submitted to GPG by Machinery Panel (Ref. '5029bIGi'). GPG was requested not to issue the Rec. XX (Surveyor training needs for surveys of electrical installations in hazardous area).
- 3) There were objections to delete Rec.35 as it concerned electrical installations in hazardous areas, whereas the "new" document regards only tankers. One member suggested revision for existing Rec.35. Based upon this it was concluded to issue this as a separate Rec. applying to tankers and keep Rec.35.
- 4) Members supported the opinion that considering the decision of publishing the document as recommendation and therefore having a non-mandatory nature, it should not contain any statement requiring its application or implementation by Members.
- 5) Members accepted changes in the draft based on following comments/observations on the draft REC. developed by the Survey Panel.
 - a. The Scope implies it is applicable to all tanker surveys but the note limits this to existing ships with a keel laying date on or after 1 January 2007. It is not felt appropriate to have different survey requirements for pre-2007 and post-2007 installations.
 - b. The document contains requirements for the equipment in hazardous areas but does not explain what will be done with equipment which has previously been installed and accepted but does not comply with these requirements.
 - c. In 2.1, there is a requirement that all the information be marked on the equipment with the statement that 'if this information is not possible to read on

- the equipment it will normally be considered as not suitable', but the standard allows for small items of equipment and identifies what must as a minimum be marked. It would be better to state the equipment marking is to be in accordance with IEC 60079 or the relevant standard to which it is constructed.
- d. It is not clear in 2.2.1 why the certificate is to be from a recognised **or** national organization. It is a member's view that even the national organization issuing the certificate should be recognised. It should be 'a recognized international or national organization'.
 - e. Also in 2.2.1, simple apparatus should be as defined in IEC 60079-11.
 - f. In 2.2.2, there is a reference to conformity with specified requirements but not clear who specifies these. These requirements should be identified as a specific standard/standards such as IEC 60079-15.
 - g. At the bottom of 2.2.2, it is not clear if the text about simple apparatus is part of the text or part of the note. It should also reference IEC 60079-11.
 - h. In 2.3, the modifications should be carried out in accordance with IEC 60079-19.
 - i. Also in 2.3, perhaps the requirement for drawings to be submitted should reference 3.1.
 - j. In 2.4 the requirement for the cable glands to be of the same protection type as the apparatus does not permit those cases where Ex e enclosures are permitted to use (and sometimes certified for use with) Ex d glands.
 - k. The note 1 in 3.1.1 indicates that if the ambient temperature is not stated it is to be understood as that in UR M40.2 but this is incorrect since if it is not stated it is 40 degrees Celsius. This note could lead to incorrectly installed equipment and a potentially unsafe situation.
 - l. The requirement for only permitting joints in IS cables in zone 0 is misleading as on most ships there will only be IS cables in zone 0. The only exception is Gas Ships, which have submerged pumps. Other cables are not permitted according to IEC 60092-502.
 - m. The requirement that 'all applicable electrical equipment' shall have insulation resistance measured could give rise to measurements being made on IS circuits resulting in damage to the apparatus. This should be warned in a note.
 - n. In 3.2.9, the term 'grounding' is used where elsewhere the term is 'earthing'. The terminology should be consistent.
 - o. In 3.2.16 it states that corrosion damage is not acceptable but it is not clear what 'corrosion damage' is. Minor surface corrosion will not adversely affect the equipment so there should be a means of determining the limit of acceptability.
 - p. In 4.1, the 'ex' should be 'Ex' and the word 'be' should be inserted before the word 'survey'. It is also recommended that there be a reference to IEC 60079-17, which covers inspection of Ex equipment.
 - q. In 4.2 there should be an 'is' inserted in the first sentence after 'equipment'.

Recommendation No.121 “Uniform Application of MARPOL Annex I, Revised Regulation 12”

Summary

The Corr.1 of Recommendation No.121 is updated to include reference to IMO Resolution MEPC.311(73).

Part A. Revision History

Version no.	Approval date	Implementation date when applicable
Corr.1 (June 2021)	02 June 2021	-
Rev.1 (Aug 2018)	07 August 2018	-
New (Dec 2011)	21 Dec 2011	-

• Corr.1 (June 2021)

.1 Origin of Change:

- Suggestion by IACS member

.2 Main Reason for Change:

To update the Recommendation to reflect IMO resolution MEPC.311(73) which clarifies that MARPOL Annex I, Reg 12 is applicable to FPSOs and FSUs.

.3 List of non-IACS Member classification societies contributing or participating in IACS Working Group:

None

.4 History of Decisions Made:

The Environmental Panel conducted the periodical review of IACS resolutions. Recognising IMO resolution MEPC.311(73) should be included in the Recommendation to clarify MARPOL Annex I, Reg 12 is applicable to FPSOs and FSUs, the Environmental Panel agreed that the Recommendation No.121 should be updated to include reference to IMO Resolution MEPC.311(73).

.5 Other Resolutions Changes:

None

.6 Any hinderance to MASS, including any other new technologies:

None

.7 Dates:

Original Proposal: 26 February 2021 (Made by Environmental Panel)
Panel Approval: 16 May 2021 (Ref: PE21003a)
GPG Approval: 02 June 2021 (Ref: 21080_IGb)

• **Rev.1 (Aug 2018)**

.1 Origin of Change:

Based on IMO Resolution MEPC.266(68)

.2 Main Reason for Change:

To update the Recommendation to take account of IMO resolution MEPC.266(68)

.3 List of non-IACS Member Classification Societies contributing through the TC Forum and/or participating in IACS Working Group:

None

.4 History of Decisions Made:

Environmental Panel has conducted a review of all IACS Resolutions responsible to the panel. As a result, the panel agreed that Rec.121 should be modified to align with the current text of Regulation 12 of MARPOL Annex I as amended by MEPC.266(68).

MEPC.266(68) no longer allows for existing arrangements where an oil residue (sludge) tank may have discharge connections to the bilge system, oily bilge water holding tank(s), tank top or oily water separators, as could be allowed under MEPC.1/Circ.753/Rev.1. Any modifications that may be required for ships constructed before 1 January 2017 with arrangements that are not compliant with the revised Regulation 12 requirements are to be completed no later than the first renewal survey carried out on or after 1 January 2017.

.5 Other Resolutions Changes

None

.6 Dates:

Panel Approval: 08 March 2018 (Ref: PE17007g)
GPG Approval: 07 August 2018 (Ref: 18081_IGe)

• **New (Dec 2011)**

.1 Origin for Change:

Suggestion by IACS Statutory Panel

.2 Main Reason for Change:

New IACS Recommendation developed by IACS Statutory Panel under the long-standing Task 3 - Monitoring of IMO and other external bodies' activities and initiatives.

.3 List of non-IACS Member classification societies contributing through the TC Forum and/or participating in IACS Working Group:

None

.4 History of Decisions Made:

The draft recommendation was prepared by Statutory Panel and approved by GPG along with UI MPC99 (Oil residue (sludge) tank discharge connections to the bilge system, oily bilge water holding tank(s), tank top or oily water separators (MARPOL 73/78 Annex I Regulation 12.2)) and draft cover paper for submission of the UI to MEPC 63.

Permsec developed a History File, to record the revision history.

.5 Other Resolutions Changes

None

.6 Dates:

Original Proposal: 14 December 2011 by Statutory Panel
GPG Approval: 21 December 2011 (Ref: 11198_IGb)

Part B. Technical Background

List of Technical Background (TB) documents for Rec.121:

*Note: There are no Technical Background documents available for New (Dec 2011) ,
Rev.1(Aug 2018) and Corr. 1 (June 2021)*

Recommendation No.122 “Integral Buoyancy Casings in Lifeboats and Rescue Boats”

Part A. Revision History

Version no.	Approval date	Implementation date when applicable
NEW (Jan 2012)	11 January 2012	-

- **NEW (Jan 2012)**

.1 Origin for Change:

- Suggestion by IACS member

.2 Main Reason for Change:

A case of rescue boat accident due to the water ingress in buoyancy chamber.

.3 List of non-IACS Member classification societies contributing through the TC Forum and/or participating in IACS Working Group:

None

.4 History of Decisions Made:

With reference of a particular case of rescue boat accident due to the water ingress in buoyancy chamber, a Survey Panel Member proposed to discuss this matter with a view to providing guidance on the assessment of integral buoyancy chambers of lifeboats and rescue boats.

Panel discussed this matter under PSU11017 and unanimously agreed with the draft IACS Recommendation, which should be followed by safety officer or the Service Company at the time of boat inspection.

GPG approved the recommendation submitted by the Survey Panel.

PermSec developed a History File, to record the revision history.

.5 Other Resolutions Changes

None

.6 Dates:

Panel Approval: *15 December 2011 by Survey Panel*
 GPG Approval: *11 January 2012 (Ref: 11199_IGb)*

Part B. Technical Background

List of Technical Background (TB) documents for Rec.122:

No Technical Background documents were developed for Rec.122 (New, Jan 2012)



Recommendation No.123 "Recommendation based on IMO instruments - MSC.1/Circ.1370 "Guidelines for the design, construction and testing of fixed hydrocarbon gas detection systems" and Resolution MSC.292 (87) "Amendments to the FSS Code Chapter 16 Fixed Hydrocarbon Gas Detection Systems""

Part A. Revision History

Version no.	Approval date	Implementation date when applicable
NEW (May 2012)	25 May 2012	-

- **NEW (May 2012)**

.1 Origin for Change:

- Suggestion by IACS Statutory Panel

.2 Main Reason for Change:

Interpretations of MSC.1 Circ.1370 and MSC.292 (87) (Long standing Task 4 – Interpretation of IMO instruments)

.3 List of non-IACS Member classification societies contributing through the TC Forum and/or participating in IACS Working Group:

None

.4 History of Decisions Made:

Statutory Panel submitted, for GPG approval, a draft paper to FP 56 seeking clarification of the meaning of "adjacent" relative to a fixed hydrocarbon gas detection systems complying with the FSS Code.

Along with the above paper, Statutory Panel also submitted a draft IACS Recommendation, for GPG approval, on Interpretations of MSC.1 Circ.1370 and MSC.292 (87).

On GPG's instruction, PermSec reviewed and amended the draft document with a view to modify its mandatory language in line with the one used in IACS Recommendations. The text in italics was also revised to make it in line with the texts from the IMO instruments.

GPG approved the recommendation with some editorial improvements.

PermSec also developed a History File, to record the revision history.

.5 Other Resolutions Changes

None

.6 Dates:

Panel Approval: *09 March 2012 by Statutory Panel*
GPG Approval: *25 May 2012 (Ref: 12032bIGd)*

Part B. Technical Background

List of Technical Background (TB) documents for Rec.123:

No Technical Background documents were developed for Rec.123 (New, May 2012)

—

Recommendation No.124 “Guidance on the role of the Recognised Security Organisation in relation to the employment of armed guards and the installation of citadels on board ships threatened by piracy in the Indian Ocean”

Part A. Revision History

Version no.	Approval date	Implementation date when applicable
NEW (May 2012)	18 May 2012	-

- **NEW (May 2012)**

.1 Origin for Change:

- Suggestion from IACS members

.2 Main Reason for Change:

IACS Expert Group (EG) ISM-ISPS drafted the recommendation in response to the increasing demand from shipping companies for advice and assistance in relation to the employment of armed guards and the installation of citadels in anticipation of attacks by pirates in the Indian Ocean and the Arabian Sea.

The Group considered that it essential that auditors and others who receive such requests be provided with guidance that is clear and consistent with the role of RSOs acting on behalf of flag administrations.

.3 List of non-IACS Member classification societies contributing through the TC Forum and/or participating in IACS Working Group:

None

.4 History of Decisions Made:

In accordance with the remit to review and maintain ISM and ISPS related IACS resolutions, the members of the ISM/ISPS Expert Group identified the need for guidance in support of the ISPS verification process described in PR24. The Group drafted a recommendation on Guidance on the role of RSOs in relation to armed guards and citadels.

GPG approved the recommendation with some modifications.

PermSec developed a History File, to record the revision history.

.5 Other Resolutions Changes

None

.6 Dates:

Expert Group Approval: *14 March 2012 by EG/ISM-ISPS*

GPG Approval: *18 May 2012 (Ref: 12042_IGe)*

Part B. Technical Background

List of Technical Background (TB) documents for Rec.124:

No Technical Background documents were developed for Rec. 124 (New, May 2012)



Recommendation No.126

“Record of approved GMDSS radio installation”

Part A. Revision History

Version no.	Approval date	Implementation date when applicable
New (Nov 2015)	12 November 2015	-

- **New (Nov 2015)**

.1 Origin for Change:

- Suggestion by IACS member

.2 Main Reason for Change:

To recast the existing Other Technical Resolutions in the IACS Blue Book into Recommendations.

.3 List of non-IACS Member Classification Societies contributing through the TC Forum and/or participating in IACS Working Group:

None

.4 History of Decisions Made:

During the discussions on the publication of updated IACS Blue Books in March 2012, a member proposed to review and recast the existing Other Technical Resolutions in the Blue Books into Recommendations. This proposal was approved by GPG.

PermSec prepared the draft Recommendations (Recs 126, 127 & 128) and also the History Files to record the revision history. Following GPG's request dated 25 July 2012 wherein Statutory Panel (now Safety Panel) was tasked to establish a small PT to review the Recs. 126 and 128 and that the proposed outcome of the PT be forwarded to the Survey Panel for their final review before being submitted to GPG for approval.

The Safety Panel concluded its final review of the Recs. 126 and 128 developed by the "one man" PT during the fourth Safety Panel Meeting taking into account the comments received from Survey Panel.

.5 Other Resolutions Changes

None

.6 Dates:

Original Proposal: March 2012 made by an IACS member (Ref: 12009_IGe)
 Panel Approval: 2 October 2015 (Ref: SP12004t)
 GPG Approval: 12 November 2015 (Ref: 12009_IGn)

Part B. Technical Background

List of Technical Background (TB) documents for Rec.126:



Note: *There is no Technical Background (TB) document available for New (Nov 2015).*

Recommendation No.127 "A Guide to Risk Assessment in Ship Operations"

Summary

Rev 1 is related to removal of reference to ISO standards and IMO Resolutions no longer in use, modification of reference to modified paragraph of ISM Code, review and update of document as part of regular IACS Recommendation 10th anniversary review process.

Part A. Revision History

Version no.	Approval date	Implementation date when applicable
Rev.1 (Nov 2021)	21 November 2021	-
New (June 2012)	19 June 2012	-

• Rev.1 (Nov 2021)

1 Origin of Change:

- ACB auditor observation and 10th anniversary review and update

2 Main Reason for Change:

Removal of reference to ISO standard ISO 8402:1995/BS 4778 and IMO Resolutions no longer in use. Updating reference to modified paragraph of ISM Code. Review and update of document as part of regular IACS Recommendation 10th anniversary review process.

3 List of non-IACS Member classification societies contributing through the TC Forum and/or participating in IACS Working Group:

None

4 History of Decisions Made:

Safety Panel Chairman in PS21015_ISa Task 8 Review of IACS Resolutions Rec. No.127 has informed safety panel members that during a recent audit of one member, an ACB Auditor identified that Rec. No.127 contained a reference to standard ISO 8402:1995/BS 4778 which has been withdrawn and that the reference shall be removed from Recommendation 127. At the same time 10th anniversary review of Recommendation 127 due in 2022 has started by Safety Panel. Following the initial job performed by Safety Panel GPG has, based on Safety Panel proposal, agreed that EG/MS will maintain IACS Recommendation 127 going forward (Ref 21141_IGb).

5 Other Resolutions Changes:

None

6 Any hinderance to MASS, including any other new technologies:

This resolution is neither related to MASS nor any new technologies on board ships.

7 Dates:

Original Proposal: 16 July 2021 (Made by: an ACB auditor)

Panel Approval: 15 October 2021 (Ref: 21141_EMSa)

GPG Approval: 22 November 2021 (Ref: 21141_IGd)

• **NEW (June 2012)**

1 Origin of Change:

- Suggestion by IACS members

2 Main Reason for Change:

To recast the existing Other Technical Resolutions in the IACS Blue Book into Recommendations.

3 List of non-IACS Member classification societies contributing through the TC Forum and/or participating in IACS Working Group:

None

4 History of Decisions Made:

During the discussions on the publication of updated IACS Blue Books in March 2012, a member proposed to review and recast the existing Other Technical Resolutions in the Blue Books into Recommendation. This proposal was approved by GPG (Ref: 12009_IGe).

PermSec prepared the draft recommendations (Recommendations 126, 127 & 128) and also the history files to record the revision history.

5 Other Resolutions Changes:

None

6 Any hinderance to MASS, including any other new technologies:

This resolution is neither related to MASS nor any new technologies on board ships.

7 Dates:

GPG Approval: 19 June 2012 (Ref: 12009_IGh)

Part B. Technical Background

List of Technical Background (TB) documents:

Annex 1. **TB for Rev.1 (Nov 2021)**

See separate TB document in Annex 1.



Note: There are no technical background documents available for New (June 2012).

Technical Background for Rec 127 (Rev.1, Nov 2021)

1 Scope and objectives

Recommendation 127 provides Guidance for Risk Assessment to Management Systems auditors on possible approach to risk assessment required by ISM and ISPS Codes.

2 Engineering background for technical basis and rationale

As part of 10th anniversary review Recommendation 127 has been reviewed and modified based on the changes to the referenced ISO standards and the ISM code since the first publication of the Recommendation in September 2012. Example of risk assessment method described in Recommendation 127 has been updated based on the latest practice.

3 Source/derivation of the proposed IACS Resolution

Following standards and IMO Documents are quoted in Revision 1 of IACS Recommendation 127

- ISM Code Edition 2018
- ISO 31000:2018
- ISO Guide 73:2009
- MSC-MEPC.2/Circ.12/Rev.2
- IEC 31010:2019

4 Summary of Changes intended for the revised Resolution

Removal of reference to ISO standards and IMO Resolutions no longer in use. Updated reference to modified paragraph of ISM Code. Update of risk matrix table used as example of Risk Assessment method within the document. Review and update of document as part of regular IACS Recommendation 10th anniversary review process.

5 Points of discussions or possible discussions

None

6 Attachments if any

None

Recommendation No.128

“Record of approved Ship Safety Equipment”

Part A. Revision History

Version no.	Approval date	Implementation date when applicable
New (Nov 2015)	12 November 2015	-

- **New (Nov 2015)**

.1 Origin for Change:

- Suggestion by IACS member

.2 Main Reason for Change:

To recast the existing Other Technical Resolutions in the IACS Blue Book into Recommendations.

.3 List of non-IACS Member Classification Societies contributing through the TC Forum and/or participating in IACS Working Group:

None

.4 History of Decisions Made:

During the discussions on the publication of updated IACS Blue Books in March 2012, a member proposed to review and recast the existing Other Technical Resolutions in the Blue Books into Recommendations. This proposal was approved by GPG.

PermSec prepared the draft Recommendations (Recs 126, 127 & 128) and also the History Files to record the revision history. Following GPG's request dated 25 July 2012 wherein Statutory Panel (now Safety Panel) was tasked to establish a small PT to review the Recs. 126 and 128 and that the proposed outcome of the PT be forwarded to the Survey Panel for their final review before being submitted to GPG for approval.

The Safety Panel concluded its final review of the Recs. 126 and 128 developed by the “one man” PT during the fourth Safety Panel Meeting taking into account the comments received from Survey Panel.

.5 Other Resolutions Changes

None

.6 Dates:

Original Proposal: March 2012 made by an IACS member (Ref: 12009_IGe)
 Panel Approval: 2 October 2015 (Ref: SP12004t)
 GPG Approval: 12 November 2015 (Ref: 12009_IGn)

Part B. Technical Background

List of Technical Background (TB) documents for Rec.128:



Note: *There is no Technical Background (TB) document available for New (Nov 2015).*

Recommendation No. 129 “Guidance on DMLC Part II review, inspection and certification under the Maritime Labour Convention, 2006”

Summary

New provisions concerning financial security for repatriation and financial security relating to shipowner’s liability, additional clarifications, few corrections.

Part A. Revision History

Version no.	Approval date	Implementation date when applicable
Rev.1 (June 2019)	15 June 2019	-
New (Mar 2013)	05 March 2013	-

• Rev.1 (June 2019)

.1 Origin of Change:

- Based on Other Standard (*Amendments of 2014 to the MLC, 2006*)
- Other (*Members’ experience*)

.2 Main Reason for Change:

New provisions concerning financial security in amended MLC, 2006 not covered by existing guidance, Members’ practical experience.

.3 List of non-IACS Member classification societies contributing through the TC Forum and/or participating in IACS Working Group:

None

.4 History of Decisions Made:

During the EG/ILO 7th meeting Members shared their practical experience with MLC inspections and decided to supplement the Rec with provisions concerning minimum time for implementation of the measures adopted by shipowner before initial certification can be carried out and with provisions concerning signing employment contract/agreement on board. Relevant text was agreed by correspondence. The text also included new provisions resulting from the Amendments of 2014 to MLC, 2006. Due to the development of new PR concerning MLC, 2006 certification it was decided to delete ad-hoc certification scenarios from this Rec and make reference to the new PR where such scenarios are included.

.5 Other Resolutions Changes:

Deletion of Rec. 118

.6 Any hinderance to MASS, including any other new technologies:

None

.7 Dates:

Original Proposal: 25 March 2019 Made by: EG/MS
EG Approval: 16 June 2017
GPG Approval: 15 June 2019 (Ref: 19058_IGe)

• **New (March 2013)**

.1 Origin of Change:

Suggestion by EG/ILO

.2 Main Reason for Change:

Uniform implementation of review, inspection and certification service under Maritime Labour Convention, 2006 (MLC).

.3 List of non-IACS Member classification societies contributing through the TC Forum and/or participating in IACS Working Group:

None

.4 History of Decisions Made:

GPG approved the recommendation. Also it was decided to publish PR 36 (Transfer of MLC 2006 Certification) along with the recommendation.

.5 Other Resolutions Changes:

None

.6 Dates:

Original Proposal: 18 January 2013 Made by: EG/ILO
GPG Approval: 05 March 2013 (Ref: 13029aIGc)

Part B. Technical Background

List of Technical Background (TB) documents for Recommendation No.129:

Annex 1. **TB for Rev.1 (June 2019)**

See separate TB document in Annex 1.

Note:

Note: There is no separate Technical Background (TB) document for Rec 129 (New, March 2013).

Technical Background (TB) document for Rec129 (Rev.1 June 2019)

1. Scope and objectives

Rec129 is intended for use by IACS Member Societies' inspectors when performing inspection and certification service under the Maritime Labour Convention, 2006 unless the relevant Administration has provided special instructions that indicate otherwise. This document is also intended to promote inspection consistency and uniformity of inspection among IACS members by providing examples and guidance, which, however, are not to be interpreted as prescriptive solutions or checklists

2. Engineering background for technical basis and rationale

Experience in the provision of MLC certification services.

3. Source/derivation of the proposed IACS Resolution

The Guidelines for Flag State Inspections under the Maritime Labour Convention, 2006. Maritime Labour Convention, 2006, as amended.

4. Summary of Changes intended for the revised Resolution

1. Two new paras in Part I 'Inspection and certification items': para 15 'Financial security for repatriation' and para 16 'Financial security relating to shipowners' liability'.
2. Additional provisions in para 4 'Seafarers' employment agreements' covering the situation when seafarer's employment agreement (SEA) is to be signed on board.
3. Additional clarification in para 8 'Accommodation' – Guidance for inspection concerning MLC, 2006 entry into force.
4. Deletion and change of some provisions in para 18 'Repatriation' due to the introduction of new para 15.
5. Deletion and change of some provisions in para 19 'Shipowners' liability' due to the introduction of new para 16.
6. Additional provisions in para 22 'Inspection process' concerning minimum time for implementation of the measures adopted by shipowner before initial MLC certification can take place.
7. Deletion of existing ad hoc certification scenarios in para 28.

5. Points of discussions or possible discussions

None

6. Attachments if any

None

Recommendation No. 130 “Procedures for verifying that materials are asbestos free”

Part A. Revision History

Version no.	Approval date	Implementation date when applicable
Rev.1 (Sept 2016)	21 September 2016	-
New (June 2013)	04 June 2013	-

- **Rev. 1 (Sept 2016)**

.1 Origin of Change:

- Suggestion by IACS member

.2 Main Reason for Change:

In view of Resolution MEPC 269(68) -2015 guidelines for the development of the inventory of Hazardous material. Environmental Panel recommended to revisit UI SC249 (Implementation of SOLAS II-1, Regulation 3-5 and MSC.1/Circ.1379) and Rec. 130 (Procedures for verifying that materials are asbestos free).

.3 List of non-IACS Member Classification Societies contributing through the TC Forum and/or participating in IACS Working Group:

None

.4 History of Decisions Made:

None

.5 Other Resolutions Changes:

None

.6 Dates:

Original Proposal: 23 Oct 2015 during GPG79-FUA 10
 Panel Approval: 22 July 2016 (Ref: EP16002)
 GPG Approval: 21 September 2016 (Ref: 16141_IGe)

- **New (June 2013)**

.1 Origin:

- Suggestion by an IACS member

.2 Main Reason for Change:

Based on the proposal of an IACS GPG Member, GPG tasked Survey Panel to develop a procedure detailing the process which would verify that the shipyard has implemented its own procedures for purchasing and controlling the supply of asbestos free material.

.3 List of non-IACS Member classification societies contributing through the TC Forum and/or participating in IACS Working Group:

None

.4 History of Decisions Made:

The Task was triggered by GPG to consider ways forward how a surveyor could be satisfied that the yards have procedures and checks to confirm that supplied materials are asbestos free.

Panel discussed and concluded that asbestos is a problem of supply chain, which only the shipyard together with its subcontractors/manufacturers can control (and, in the case of ships in service, only the Owner and its suppliers) and therefore yard should have full control and procedure for purchasing asbestos free material. It is the opinion of Panel that shipyard should have their own procedure and it is RO's responsibility only to monitor the procedure.

A new IACS Recommendation has been developed as guidelines for new building yards, owner, manufacture of equipment and components for having a procedure of purchasing and controlling asbestos free material.

.5 Other Resolutions Changes:

None

.6 Dates:

Panel Approval: *7 March 2013 by Survey Panel (Ref: PSU12001)*

GPG Approval: *04 June 2013 (Ref: 11073 _IGu)*

Part B. Technical Background

List of Technical Background (TB) documents for Rec. 130:

Note:

1) There are no separate Technical Background (TB) documents for Recommendation No.130 New (June 2013) and Rev.1 (Sept 2016).

Recommendation No. 131 “Guidelines for application of SOLAS Ch.II-2 Reg. 4.5.7.3.2 for accepting a constant operative inerting systems (COIS) as an alternative to fixed hydrocarbon gas detection equipment in double hull and double-bottom spaces on oil tankers”

Summary

This revision of the Recommendation 131 has been developed to consider relevant amendments to IMO instruments within the last decade.

Part A. Revision History

Version no.	Approval date	Implementation date when applicable
Rev.1 (Nov 2023)	09 November 2023	-
New (July 2013)	23 July 2013	-

- **Rev.1 (Nov 2023)**

1 Origin of Change:

- Based on IACS Requirement (Periodic review of IACS Resolutions)

2 Main Reason for Change:

SOLAS Chapter II-2 regulation 4 has been amended by MSC.520(106) (applicable for ships constructed from 1 January 2026) and MSC.365(93) (applicable for ships constructed from 1 January 2016 to 1 January 2026), and the FSS Code has been amended by MSC.457(101) applicable from 1 January 2024.

In context of IACS maintenance references in this recommendation were updated according to amendments 131 and minor editorial changes made to improve clarity.

3 List of non-IACS Member classification societies contributing or participating in IACS Working Group:

None

4 History of Decisions Made:

The revision was developed by the Safety Panel by correspondence and agreed by all Members of IACS Safety Panel.

5 Other Resolutions Changes:

None

6 Any hinderance to MASS, including any other new technologies:

None

7 Dates:

Original Proposal:	21 July 2023	(Made by: Safety Panel)
Panel Approval:	21 September 2023	(Ref: PS23036e)
GPG Approval:	09 November 2023	(Ref: 22183eIGc)

• New (July 2013)

1 Origin of Change:

- Suggestion by IACS Statutory Panel & Machinery Panel

2 Main Reason for Change:

The Recommendation has been developed by the Statutory Panel and consequently agreed by the Machinery Panel to achieve a uniform understanding of the term "constant operative inerting systems" introduced with new SOLAS regulation II-2/4.5.7.3.2 and ensure a consistency in its implementation by IACS Societies.

3 List of non-IACS Member classification societies contributing or participating in IACS Working Group:

None

4 History of Decisions Made:

The recommendation was developed by the Statutory Panel, in cooperation with the Machinery Panel, under the long-standing Task 4 - Interpretation of IMO instruments and agreed by all Members of IACS Machinery and Statutory Panels.

5 Other Resolutions Changes:

None

6 Dates:

Panel Approval: *18 June 2013 by Statutory Panel & Machinery Panel (Ref: PM129006 & SP11010y)*

GPG Approval: *23 July 2013 (Ref: 13153_IGc)*

Part B. Technical Background

Note: No separate Technical Background (TB) document is available for Rec.131 New (July 2013), Rev.1 (Nov. 2023).

Recommendation No. 132 “Human Element Recommendations for structural design of lighting, ventilation, vibration, noise, access and egress arrangements”

Part A. Revision History

Version no.	Approval date	Implementation date when applicable
New (Dec 2013)	05 December 2013	-

- **New (Dec 2013)**

.1 Origin:

- Suggestion by IACS EG/GBS

.2 Main Reason for Change:

The Recommendation has been developed by EG/GBS in view of IMO GBS audits.

.3 List of non-IACS Member classification societies contributing through the TC Forum and/or participating in IACS Working Group:

None

.4 History of Decisions Made:

The recommendation was developed by EG/GBS. Contents of the Rec. 132 are related to SOLAS regulation II-1/3-6, UI SC191 and statutory requirements specified in MLC 2006. GPG approved the recommendation and requested EG/GBS to continue working on it with a view of preparing for IMO GBS audit.

.5 Other Resolutions Changes:

None

.6 Dates:

EG Approval: *15 November 2013 by EG/GBS*

GPG Approval: *05 December 2013 (Ref: 13248_IGb)*

Part B. Technical Background

Note: No separate Technical Background (TB) document is available for Rec.132 (New Dec 2013).

Recommendation No.133

“Guidelines for Pilot Schemes of Extended Interval between Surveys in Dry-Dock - Extended Dry-docking (EDD) Scheme”

Part A. Revision History

Version no.	Approval date	Implementation date when applicable
New (Nov 2013)	20 November 2013	-

- **New (Nov 2013)**

1 Origin for Develop:

- Suggestion by IACS GPG

.2 Main Reasons for Develop:

1. To consider the technical feasibility and practicality of carrying out an extended dry-docking (EDD) programme.
2. To develop an IACS Recommendation on Extended Dry Docking (EDD) to ensure and demonstrate that there is a common technical understanding amongst IACS Members on how such an EDD scheme will operate.

.3 List of non-IACS Member classification societies contributing through the TC Forum and/or participating in IACS Working Group:

None.

.4 History of Decisions Made:

Survey Panel initiated this discussion due to the declaration of one IACS Member that it would maintain reservation on IACS UR Z7.1 by adapting a new concept of dry docking survey scheme for allowing selected ships fulfilling the criteria to carry out 2 consecutive bottom surveys afloat.

At first round of discussion under PSU10016, Panel noted that the concept of extending dry docking is not a new concept but a simple extension of a survey interval based upon improved technologies. Panel discussed different aspects regarding carry out 2 consecutive bottom surveys afloat and reported to GPG for further instruction.

Panel involved in second round of discussion, based on GPG's specific instructions, under PSU11016 with a view to develop common understanding among IACS Members. At first stage Panel concentrated on technical feasibility and practicality of carrying out an extended dry-docking (EDD) programme such as types of vessels which could enter in EDD scheme, specific survey requirements, how to conduct surveys for some specific items, availability of coating regimes etc.

Based on the outcome and agreement on various technical issues, Panel further developed an IACS guideline for EDD as pilot scheme. This IACS document recommends the acceptance procedure to a scheme which extends the interval between surveys in dry-dock. Ships eligible for the Extended Dry-Docking (EDD) scheme should meet the provisions and conditions described in this document.

.5 Other Resolutions Changes

None.

.6 Dates:

Original Proposal: 26 March 2010 by Survey Panel Chairman

Survey Panel Approval: 5 September 2013 during 18th Survey Panel Meeting

GPG Approval: 20 November 2013 (Ref: 10040aIGd)

Part B. Technical Background

Note: No Technical Background (TB) document has been prepared for Recommendation No.133 (New, Nov 2013).

Recommendation No.134 "Boat Transfers Safe Practice"

Summary

This Recommendation has been updated to align provisions of the document with Members own internal procedures/rules, their experience/expertise, as well as relevant requirements/guidelines of IMO, ISO/IEC standards, other international standards, and best practices within the industry.

Part A. Revision History

Version no.	Approval date	Implementation date when applicable
Rev.1 (Oct 2022)	24 October 2022	-
New (Mar 2014)	05 March 2014	-

• Rev.1 (Sep 2022)

1 Origin of Change:

Other (Suggestion by IACS GPG)

2 Main Reason for Change:

The benefits of developing/revising the Boat Transfers standard are:

1. Enable consistent approach to a critical risk all Members face
2. Establish good practice for boat transfer, potentially defining minimum standards for transfer vessels, training requirements, equipment and safe boarding arrangements for the different forms of boat transfer

3 List of non-IACS Member classification societies contributing or participating in IACS Working Group:

None.

4 History of Decisions Made:

The EG/SOS has revised the Rev.134 by correspondence within the EG members by considering Members own internal procedures/rules, experience/expertise of Members, relevant requirements/guidelines of IMO, ISO/IEC standards, other international standards and best practices within the industry.

All the amendments/changes made by the EG/SOS are agreed by all members unanimously except for Para 5.2.1 – The text has been retained based on the majority. All members except one member have agreed to retain the text as it is.

5 Other Resolutions Changes

None.

6 Any hinderance to MASS, including any other new technologies:

None.

7 Dates:

Original Proposal	: 18 February 2022	(by IACS GPG)
EG Approval	: 10 September 2022	(by EG/SoS)
GPG Approval	: 24 October 2022	(Ref: S/N 22141)

• New (Mar 2014)

.1 Origin for Develop:

Other (Suggestion by IACS GPG)

.2 Main Reasons for Develop:

This recommendation is intended to provide Societies with reference information to be used in developing Boat Transfer procedures or technical instructions for their Surveyors, according to a common reference standard of good practice.

.3 List of non-IACS Member classification societies contributing through the TC Forum and/or participating in IACS Working Group:

None.

.4 History of Decisions Made:

EG/SoS developed the recommendation as requested by GPG using a draft Procedure Requirement (PR) originally developed based on EG members' expertise and members' internal procedures and requirements for Boat Transfers.

.5 Other Resolutions Changes

None.

.6 Dates:

Original Proposal	: 07 October 2013	(by IACS GPG)
EG Approval	: 20 January 2014	(by EG/SoS)
GPG Approval	: 05 March 2014	(Ref: 13055_IGq)

Part B. Technical Background

List of Technical Background (TB) documents for Rec 134:

Note: *There are no Technical Background (TB) documents available for Rev.1 (Oct 2022) and New (Mar 2014).*

Recommendation No.136 "Guidelines for Working at Height"

Part A. Revision History

Version no.	Approval date	Implementation date when applicable
New (June 2014)	30 June 2014	-

- **New (June 2014)**

1 Origin for Develop:

- Suggestion by EG/SoS

.2 Main Reasons for Develop:

A new Recommendation on "Working at Height" (WAH) was developed by EG/SOS, as Task No. 5 (WI2), to establish procedures designed to promote the safety of personnel when conducting WAH activities.

.3 List of non-IACS Member classification societies contributing through the TC Forum and/or participating in IACS Working Group:

None.

.4 History of Decisions Made:

Document was drafted with input from all EG members and reviewed and accepted by all EG members.

.5 Other Resolutions Changes

None.

.6 Dates:

Original Proposal: May 2014 by EG/SoS
 EG/SoS Approval: 31 May 2014
 GPG Approval: 30 June 2014 (Ref: 14091_IGb)

Part B. Technical Background

Annex 1. **TB for New (June 2014)**

See separate TB document in Annex 1.



Technical Background (TB) document for IACS Recommendation 136 (New, June 2014)

1 Scope and objectives

It is recommended that IACS Societies consider the information contained in this document when establishing procedures designed to promote the safety of their personnel when conducting Working at Height (WAH) activities. The recommended practices contained herein apply specifically to survey activities carried out on existing vessels, during new construction, at repair yards and in vendors' fabrication shops and facilities. Individual Societies' procedures should also take into account relevant occupational safety and health regulatory requirements applicable at locations where such work is conducted.

2 Engineering background for technical basis and rationale

IACS Societies' survey staffs are frequently required to work at heights when carrying out their duties. Such work can be hazardous if appropriate safety procedures are not fully implemented. IACS has not, until now, provided members with specific guidance regarding WAH. This Recommendation is intended to provide such guidance.

3 Source/derivation of the proposed IACS Resolution

- EG member expertise
- EG member internal procedures and requirements for WAH
- See also referenced documents in the Guidelines

4 Summary of Changes intended for the revised Resolution

This is the original draft resolution. No changes are intended at this point.

5 Points of discussions or possible discussions

- The responsibility to develop appropriate guidance was assigned to a small working group. A draft was developed which was submitted to all EG members in late 2013.
- The document was then subject to various reviews and comments by EG members.
- The Recommendations are based upon recognized standards and members' own practical experience.
- All EG members that attended the annual group meeting of 25 to 27 February 2014 participated in the review of the document that was brought into completion as a final draft.
- Final clean up and formatting was reassigned to the subgroup.
- The final draft was submitted again to all EG members and, following further adjustments, it was accepted by the group on 30 May 2014.

6 Attachments if any

None

Recommendation No.137
“Recommendation for protection of socket outlets for road freight units”

Part A. Revision History

Version no.	Approval date	Implementation date when applicable
New (Oct 2014)	02 October 2014	-

- **New (October 2014)**

1 Origin for Develop:

- Suggestion by MAIB through Machinery Panel

.2 Main Reasons for Develop:

As a result of a fire on the main vehicle deck of a ro-ro passenger vessel (MAIB Safety Bulletin 3/2010 refers), IACS was asked by the UK Marine Accident Investigation Branch to address the issue of electrical fault protection systems installed in electrical power circuits supplying road freight units stored on vehicle deck, special category and ro-ro spaces. Upon further consideration, IACS agreed that a Recommendation would be the most suitable instrument to address this issue.

.3 List of non-IACS Member classification societies contributing through the TC Forum and/or participating in IACS Working Group:

None.

.4 History of Decisions Made:

Machinery Panel agreed to develop an IACS Recommendation to ensure that power supply cables and fittings provided for refrigerated trailer units are in good condition and that electrical protection devices activate at an appropriate level. Form A was developed for task No: PM11924. Recommendation developed by Machinery Panel was approved by GPG.

.5 Other Resolutions Changes

None.

.6 Dates:

Original Proposal: 14 February 2013
 Panel Approval: 01 September 2014 (By Machinery Panel)
 GPG Approval: 02 October 2014 (Ref: 13050_IGc)

Part B. Technical Background

Note: There is no Technical Background (TB) document developed for Rec 137 (New, Oct 2014).

Recommendation No. 138

“Recommendation for the FMEA process for diesel engine control systems”

Part A. Revision History

Version no.	Approval date	Implementation date when applicable
New (Dec 2014)	11 December 2014	-

- **New (Dec 2014)**

.1 Origin for original version:

- Suggestion by IACS member

.2 Main Reason for proposal:

Based on CIMAC WG 15 (through WG 2) request from 2012-08-20 towards IACS Machinery Panel to provide guidance for a uniform approach for the FMEA as required in IACS UR M44.

.3 List of non-IACS Member Classification Societies contributing through the TC Forum and/or participating in IACS Working Group:

None

.4 History of Decisions Made:

A first draft of the document was agreed unanimously at the 19th Machinery Panel meeting (February 2014) and subsequently circulated to CIMAC for comments. Comments from CIMAC WG 2 and WG 15 were received on 2014-06-16, reviewed by the Panel, and incorporated in the Recommendation as appropriate.

.5 Other Resolutions Changes

Refer UR M44.

.6 Dates:

Original Proposal: 22 July 2014 , Made by: Machinery Panel
 Panel Approval: 10 November 2014 (Ref: PM12918_IMI)
 GPG Approval: 11 December 2014 (Ref: 13000_IGc)

Part B. Technical Background

List of Technical Background (TB) documents:

Annex 1. TB for New (Dec 2014)

See separate TB document in Annex 1.



Technical Background (TB) document for Rec. 138 (New Dec 2014)

1. Scope and objectives

To provide guidance on the FMEA process and documentation as required in UR M44

2. Engineering background for technical basis and rationale

IACS UR M44 defines the documents required for the approval of diesel engines. For engine control systems the following item and respective footnote is listed in Table 1 of UR M44:

25	FMEA (for engine control system) ⁵
----	---

5. Where engines rely on hydraulic, pneumatic or electronic control of fuel injection and/or valves, a failure mode and effects analysis (FMEA) is to be submitted to demonstrate that single failure of the control system will not result in the operation of the engine being degraded beyond acceptable performance criteria for the engine. The FMEA reports required will not be explicitly approved by the classification society.

FMEA is a widely used tool to support the design process of complex and innovative designs. While there are a range of standards and accepted industry practices available, experience shows that FMEA submitted to class as required by UR M44 for engine control systems vary significantly in scope, process and documentation.

The Recommendation was developed in response to a request from CIMAC for guidance on a uniform approach towards this particular FMEA application. It draws on existing standards, experience gained since the introduction of the FMEA requirement in UR M44 and current industry practice. The focus lies on the process and documentation requirements. More general aspects of the FMEA method are readily available in the literature and not covered by this Recommendation.

3. Source/derivation of the proposed IACS Resolution

The provisions of this Recommendation are based on:

- Recognized standards such as HSC-Code Annex 3 and Annex 4 and IMCA M 166
- Experience gained in the application of the FMEA requirement since its introduction
- Current industry practice
- CIMAC WG 15 document 'Information towards IACS Machinery Panel: Input to FMEA requirements as defined in UR M44' dated 20 August 2012

4. Summary of Changes intended for the revised Resolution:

N/A

5. Points of discussions or possible discussions

The Recommendation was agreed unanimously at the 19th Machinery Panel meeting (February 2014) and subsequently submitted to CIMAC for comment. Comments

received from CIMAC were reviewed by the Panel, incorporated as appropriate and the Panel position on individual items returned to CIMAC (see attachments).

6. Attachments if any

Attachments 1:

CIMAC WG 15 'Information towards IACS Machinery Panel: Input to FMEA requirements as defined in UR M44' dated 20 August 2012

Attachment 2:

Comments received from CIMAC WG 15 with Machinery Panel positions

Attachment 3:

Comments received from CIMAC WG 2 with Machinery Panel positions

Attachment 1

CONSEIL INTERNATIONAL
DES MACHINES A COMBUSTION



INTERNATIONAL COUNCIL
ON COMBUSTION ENGINES

CO-ORDINATING WORKING GROUP

"ELECTRONICS & SOFTWARE"

(WG15)

Information towards IACS Machinery Panel

R.Boom/chairman/WG15

20.08.2012

Subject: Input to FMEA requirements as defined in UR M44

Background

The IACS Machinery Panel has requested CIMAC to deliver input to the FMEA requirements, which are described in UR M44. A recurring theme from the engine industry has been the variation in documentation requirements from the different classification societies. A more unified requirement would be of the benefit of the classification societies and industry.

CIMAC WG15 members are active in the 2- and 4-stroke engine control and automation system and responsible for control system architecture, software and hardware design and final system integration. The failure mode effect analysis (FMEA) is a commonly used tool in control- and safety systems designs. The pragmatic experiences with the FMEA as a tool are valuable assets, which enables the CIMAC WG15 members to provide input to the IACS Machinery Panel

M44

Defines the required documents for the approval of diesel engines. M44 requires under item #28 a schematic diagram of engine control and safety system on the engine. Item #28 is identified with an „A“ as being documentation to be approved by Classification Society. A footnote is made to item #28 stating the following

6. and the system so far as supplied by the engine manufacturer. Where engines incorporate electronic control systems a failure mode and effects analysis (FMEA) is to be submitted to demonstrate that failure of an electronic control system will not result in the loss of essential services for the operation of the engine and that operation of the engine will not be lost or degraded beyond an acceptable performance criteria of the engine.

An additional note is made to the above footnote

The FMEA reports required by FOOTNOTE 6 will not be explicitly approved by the Classification Society

The M44 doesn't define a format on how the requested FMEA information needs to be presented. This is left to the judgement of the submitting engine builder and individual classification society. A minimum documentation requirement definition is

considered to be useful to perform a proper assessment of the FMEA work and results.

Proposal

CIMAC WG15 proposes that there will be no format requirements be specified in M44. The objective of M44 should be that the requested information is used to verify an FMEA has been done as part of the design and validation of the engine control- and safety system. The submitted documentation needs to provide the classification society the proof that the FMEA has been used to identify and mitigate risks to an acceptable level.

The submitted FMEA documentation should contain therefore the following as an absolute minimum, but not limited to:

- General information:
 - ◻ Description of the engine application, primarily defining:
 - Single main engine propulsion
 - Multiple engines (D/E and D/M)
 - Auxiliary engine
 - Emergency engines
 - ◻ Specification: The specification from shipyard which identifies the control- and safety system definition and identifies the requirements

- The overall electronic control- and safety system boundaries to be subject for FMEA. The FMEA is considered to be applicable to the control- and safety system of the engine only.
 - ◻ Block diagram
 - ◻ I/O signal specification
 - ◻ Interface signal specification
 - ◻ Monitoring system - HMI
 - ◻ Network connection – CAN bus, Ethernet,....
 - ◻ Sensors
 - ◻ Actuators
 - ◻ Protection – ground fault for example
 - ◻ Hardwired safety circuits
 - ◻ Power supply arrangement

- Acceptance criteria for the electronic control- and safety system performance
 - ◻ List of acceptable " consequences "
 - ◻ List of NOT acceptable " consequences "
 - ◻ Application specific exemptions

- Design intent(s) and system operational modes for the electronic control system
 - ◻ Functional description
 - ◻ Description of manual operation,
 - ◻ Description of local/remote mode
 - ◻ List specific environmental issues, like EMC

- Consider E10 requirements for electronic modules/hardware
 - Describe redundancy if required
 - Power supply requirements
 - Alarms/warnings
 - Control- & safety system – separation – independency
- All component groups included within the electronic control system boundary. The relevant system names, main units and their main intended functions shall be presented in a structured manner, supported with a descriptive narrative text.
 - Listing of components
 - Part list
 - Descriptive narrative text to support Block Diagram
 - Processor module, I/O modules make clear
 - Split system in "independent" processors – multiple CPU based systems
 - Describe how multiple CPU operate from a concept/system architecture perspective
 - Distributed control system architecture
- All assumptions related to systems interfaces and dependencies of external systems
 - Di-electrical isolation
 - Quality of power supply
 - Pneumatic / hydraulic systems – actuators
 - Cables and connectors
 - Type of contacts – dry contact/ open collector type/.....
- Single failure and common cause analysis at electronic control system levels
 - Single failure is different from common cause
 - Common cause: over/under voltage for example
 - Single failure: wire break for example
 - All excessive environmental conditions – use of type approved hardware
 - Cabling/termination examples
- A reference to a test program to support the conclusions shall be included or referred
 - Based on FMEA analysis – outcome of the FMEA when used as the tool
 - Test program will follow from specification

CIMAC WG15 has reviewed the recommended practice document from DNV (DNV-RP-D102). This document is considered a good reference document for the M44 requirements. The document provides good examples on the above listed documentation requirements.

Attachment 2

CO-ORDINATING WORKING GROUP

"ELECTRONICS & SOFTWARE"

(WG15)

R.Boom/chairman/WG15

21.05.2014

Subject: Comments to the PM12918 draft IACS recommendation for FMEA requirements for UR M44

Dear Mr.Peter Baum-Müller,

Within the CIMAC WG15 we have discussed and evaluated the draft document from the IACS Machinery Panel, PM12918, on the FMEA requirements per UR M44. As a result the WG15 has identified several areas where additional clarification is required and comments on the draft text. In some cases an alternative text or suggestion is provided. In this document the WG15 comments are categorized by chapter and paragraph, as per draft PM12981 document.

The title of the document refers to Diesel engines only.

- Why is the document referring to Diesel engines only ?

1.1

The reference does not seem to refer to the newest released version of UR M44. It would probably be as relevant to refer to UR E22, in which the design documentation to form the basis for the FMEA is already specified.

- Why are there “nested” references and duplications between UR M44 and UR E22 ?
- Are there any other cross-references taken into consideration ?

1.2.3.

The reference to the standard IEC60812 implies a bottom up approach while the UR M44 tries to do a top down approach.

It's therefore suggested to consider deleting paragraph 1.2.3. As it's incomplete, not precise and inconsistent. In addition it referred as an example only.

1.3.3.

This paragraph is stating the obvious about the FMEA as a development tool.

- What is the purpose of having this paragraph ?

Or specifically the sentence “*Any failure mode which may cause an effect on the system beyond previously agreed acceptance criteria shall be mitigated by system or equipment redundancy*”

Note: Equipment redundancy is not the only countermeasure against unacceptable risk

1.3.4

It's suggested to consider modifying the text as “*The assumptions stated within the FMEA shall be confirmed within the development process*”

1.4

It has been noted that the definition of safety given in the acronyms and definition overview is not the same as which is defined in the IEC 61508. It's therefore suggested to consider to remove the reference to IEC61508 from the safety definition.

It has been noted that the functional safety is not used in the document. The suggestion is to remove it from the acronyms and definition overview.

It has been noted that the CCF is only explained as the acronym for common cause failure. It's suggested to provide an additional explanation. For example: *'Failures of different items, resulting from a single event, where these failures are not consequences of each other.'*

It's suggested to consider to modify the definition of FMEA by replacing *'demonstrate that no single failure will cause an undesired event'* with *'identify the potential failure modes, their causes and effects on the performance of a system'*.

2

The draft document describes the FMEA document to be a self contained and stand alone document. To the opinion of WG15 this should not be required. The FMEA is a part of the total package of documents that is required and defined in UR E22. Therefore it should be allowed to refer to existing documents.

It's noted that in figure 1. there is step "10" defined, as input to the test program. This step is not part of the FMEA process itself. It's suggested to delete this step from the document.

Figure 1. is specifically labeled as an example.

- Does this mean there could be a deviation from the example and follow a different process ?

The 10 steps from the example are a collection of inputs, FMEA process and outputs. It's suggested to consider to visualize in the diagram what is considered input, what is the FMEA process and what is the output.

2.1.

The generation of the system description, as specified in section 2.1, is not a part of the FMEA process. It is assumed that these descriptions are available before the FMEA process is started. This is considered an essential INPUT for the FMEA process itself and not part of the FMEA process.

2.1.3.

The sentence "Redundancy level and nature of the redundancies, separation independency" is not clear.

- What is exactly meant with these words ? i.e. the word redundancies is typically used in other contexts.

2.1.4.

Evidence of hardware type approval is already required as part of the engine documentation. It seems irrelevant as input to an FMEA, especially if this is made as part of the design process, it can only be assumed that the components are appropriate for the purpose, - alternatively requirements to components are identified during the elaboration of the FMEA.

2.2.

It's noted that 2.2 is an INPUT required for the FMEA process itself and not part of the FMEA process.

2.4.

Is it relevant to consider two levels, engine and engine application? If the first level is enough, inclusion of a second level will introduce an unnecessary overhead.

It's suggested to consider to remove the text about the two levels.

2.5.

It's suggested to include a manual inspection as a possible detection method.

2.10.

Is an OUTPUT of the FMEA process

Note: This is a requirement to the test specification, not to the FMEA. It is already specified in M50, sec. 3.3.5 and M51, sec. 1.5. This section could be moved to E22. If wished to be included here, it could be changed to a guiding note of: The FMEA should be an input to the development of test specifications in general and particularly for identification of relevant test to be done during Type Approval Test (TAT) and Factory Acceptance Test (FAT) respectively.

3

WG15 considers the FMEA process as a development tool. The FMEA process is an essential part of the complete development process. Already existing documents from the development process should not be duplicated into an FMEA report. I.e. the FMEA report should not be a self-contained document in that respect. The requested information, as described as the FMEA report, is partly redundant. I.e. information is already available and considered essential input to the FMEA process.

Therefore it's suggested to consider to delete the requirement that the FMEA report has to be a self-contained and stand-alone report. The FMEA report should be a part of the complete engine documentation per UR E22.

I hope the above comments and suggestions are of value to the IACS MP and I'm looking forward to their comments.

Yours sincerely,

Rick Boom
Chairman CIMAC WG15

Attachment 3

Template for comments and IACS MP observations

Date:	Document: M44 FMEA	Project:
-------	---------------------------	----------

Comp. / NMA ¹	Clause/ Subclause	Paragraph/ Figure/ Table	Type of comment ²	Comments	Proposed change	Observations of IACS Machinery Panel
MTU	M44 FMEA			“diesen Entwurf zur FMEA Durchführung sehen wir als unkritisch. Es wird immer nur von „Empfehlung-recommendation“ und „sollte-should“ gesprochen.		
		1.2.3		Unter 1.2.3 werden Standards (IEC 60812, HSC-Code Annex 3 and Annex 4 and IMCA M 166) zur FMEA-Durchführung genannt. Die MTU hat sich an den VDA 4-2012 angelehnt. Es wäre hier sinnvoll, wenn dieser VDA-Standard auch aufgeführt wird.		IACS documents should refer to international standards.
		1.3		Unter 1.3 wird von „System-FMEA“ gesprochen. Im aktuellen VDA 4-2012-Band existiert dieser Begriff nicht mehr. Dort existieren nur noch die Begriffe „Produkt-FMEA“ und „Prozess-FMEA“. Der „alte“ Begriff „System-FMEA“ wurde durch „Produkt-FMEA“ ersetzt. ”		The Recommendation suggests a more practical approach for the present application than a ‘standard’ FMEA/FMECA, which is top-down. IACS documents should refer to international standards.
MDT	M44 FMEA			See comments by MDT below		
Cummins	M44 FMEA	1.3.4		By the nature of FMEA, some of the failure modes will be at extremes of operating parameters (voltage, current, temperature, pressure, etc.) not likely to occur during normal situations. Requiring a test to be performed is not necessary, when engineering judgment, analysis, past experience and/or other inputs to the FMEA lead to a conclusion of failure. For example, what is gained by predicting a failure in the FMEA, and then conducting a test to confirm the FMEA is right (and damaging or destroying parts/assemblies/engines in the process)?	Since the FMEA is a rigorous and cross-functional exercise, and the final FMEA document can stand on it's own merits, I submit that a validation test is unnecessary. Section 1.3.4 should be removed.	Text modified to: Test programme of <u>selected items</u> . Test programme to be agreed with classification society.

¹ **Company or National Member Association** (NMA - enter the ISO 3166 two-letter country code, e.g. CN for China)

² **Type of comment:** **ge** = general **te** = technical **ed** = editorial

Recommendation for the FMEA process - Comments by MDT

ID	Page no.	Reference	Comment
5	1	1.1 Introduction	The reference does not seem to refer to the newest released version of UR M44. It would probably be as relevant to refer to UR E22, in which the design documentation to form the basis for the FMEA is already specified.
6	3	2.1 Define and describe the sy	The objective of the analysis should be the actual design, which means that the actual design documentation would be the most relevant to use, i.e. a list of referenced documentation of specific version should be appropriate (or even better) for the analysis. It will be an advantage to base the analysis on documentation which is elaborated and used also for other purposes, 1) to avoid analysis based on branched 'dead' documentation, which is not kept up to date during design process, 2) to promote the analysis to be an integrated process of the development, and 3) to limit the work of the analysis, which otherwise may suffer in resources and thereby in quality. I.e. the FMEA documentation should be an item in the engine control system documentation package, instead that the engine documentation are items in the FMEA package (ref. UR E22).
7	4	2.1.4 Evidence of Hardware...	Evidence of hardware type approval is already required as part of the engine documentation. It seems irrelevant as input to an FMEA, especially if this is made as part of the design process, it can only be assumed that the components are appropriate for the purpose, - alternatively requirements to components are identified during the elaboration of the FMEA.
8	6	2.10 Describe input to test pr	This is a requirement to the test specification, not to the FMEA. It is already specified in M50, sec. 3.3.5 and M51 , sec. 1.5. This section could be moved to E22. If wished to be included here, it could be changed to a guiding note of: The FMEA should be an input to the development of test specifications in general and particularly for identification of relevant test to be done during Type Approval Test (TAT) and Factory Acceptance Test (FAT) respectively.
9	6	3 FMEA report	The objective of the analysis should be the actual design, which means that the actual design documentation would be the most relevant to use, i.e. a list of referenced documentation of specific version should be appropriate (or even better) for the analysis. It will be an advantage to base the analysis on documentation which is elaborated and used also for other purposes, 1) to avoid analysis based on branched 'dead' documentation, which is not kept up to date during design process, 2) to promote the analysis to be an integrated process of the development, and 3) to limit the work of the analysis, which otherwise may suffer in resources and thereby in quality. I.e. the FMEA documentation should be an item in the engine control system documentation package, instead that the engine documentation are items in the FMEA package (ref. UR E22).

1 **Company or National Member Association** (NMA - enter the ISO 3166 two-letter country code, e.g. CN for China)

2 **Type of comment:** **ge** = general **te** = technical **ed** = editorial

Template for comments and IACS MP observations

Date:	Document: M44 FMEA	Project:
-------	---------------------------	----------

			What is the difference between a FMECA and the approach described in this document? If a FMECA is required, it would be better to call it a FMECA.
10	1	1.2.2 the analysis recommended	It is important that this document explicitly states whether it concerns a FMEA or a FMECA.
11	1	1.3.3 Any failure mode which	remove "previously"
12	1	1.3.3 by system or equipment	Remove 'by system or equipment redundancy'. (There are other means to mitigate an undesired effect than redundancy).
13	2	1.4 table 1: acronyms and defi	Include the term 'FMECA' - if required!
14	2	1.4 CCF common cause failure	Define the term 'Common Cause Failure'. Proposal: 'Failures of different items, resulting from a single event, where these failures are not consequences of each other.'
15	2	1.4 table 1 FMEA	Replace 'demonstrate that no single failure will cause an undesired event' with 'identify the potential failure modes, their causes and effects on the performance of a system'.
16	1	1.4 Function	This definition should be complied with throughout the document!
17	2	1.4 Functional Sa [IEC 61508].	Should be defined in the 'References' section.
18	3	2 - The FMEA report shall be	It should be allowed to include references to existing descriptions.
19	3	2 - fig 1.Describe Input to te	This activity belongs to test planning - not FMEA
20	3	2.1 the narrative description	Production of the system description, as specified in section 2.1, is not a part of the FMEA process. It is assumed that these descriptions are available before the FMEA process is started.
21	5	table 3	The interval: '1 event in 10 to 1 event in 1 engines per year in engine operation' is missing!
22	5	2.4 The failure effects are to	Is it relevant to consider two levels, engine and engine application? If the first level is enough, inclusion of a second level will introduce an unnecessary overhead.
23	6	section 2.10	Remove section 2.10 and include the information in the test plan.
24	6	3 - A full description of the	This should be provided through references to existing documentation.
25	6	3 - without any need to refer	sentence to be removed.
26	7	3 As well as the reference to	To be removed.

IACS Machinery Panel: Answers to most comments by MDT are provided in CIMAC WG 15 document 'Comments to the PM12918 draft IACS recommendation for FMEA requirements for UR M44' dated 21.05.2014.

ID 10: 1.2.2: FMEA may also include assessment of severity and probability, see e.g. HSC Code

1 **Company or National Member Association** (NMA - enter the ISO 3166 two-letter country code, e.g. CN for China)

2 **Type of comment:** **ge** = general **te** = technical **ed** = editorial

Recommendation No. 139 “Guidelines on Approval of Hull Steels with Improved Fatigue Properties”

Part A. Revision History

Version no.	Approval date	Implementation date when applicable
New (Feb 2015)	2 February 2015	-

- **New (Feb 2015)**

1 Origin for Change:

- Suggestion by IACS Members

.2 Main Reason for Change:

None – new document.

.3 List of non-IACS Member classification societies contributing through the TC Forum and/or participating in IACS Working Group:

None

.4 History of Decisions Made:

See technical background document in Part B Annex 1.

.5 Other Resolutions Changes

None

.6 Dates:

EG/MW Approval: 12 January 2015

GPG Approval: 2 February 2015 (Ref: 12108_IGj)

Part B. Technical Background

Annex 1. TB for Rec. 139 (New, Feb 2015)

See separate TB document in Annex 1.

Technical Background document for Rec. 139 (New, Feb 2015)

1. Scope and objectives

The Japanese steel industry has developed hull steels with improved fatigue properties to retard the initiation of and propagation of fatigue cracks (fatigue resistant steels). Application of fatigue resistant steels for various vessels such as bulk carriers, oil tankers, LPG/LNG tankers, PCC, etc. will have huge benefits to the marine construction industry especially in design hot spots known to have high risk fatigue cracking. IACS recognized that it is necessary to develop the recommendation (Rec.) on fatigue resistant steels covering following items;

- Material specification
- Manufacturing approval scheme
- Production testing requirement.

2. Engineering background for technical basis and rationale

Several issues were highlighted that IACS needed to address:

- a) Fatigue resistant steels are hull structural steels. The mechanical properties and chemical composition of fatigue resistant steels shall conform to those of conventional hull structural steels.
- b) The criteria S-N curves are specified as key material specification of the fatigue resistant steels considering that the fatigue crack growth rate can not be directly applied to the calculation of cumulative fatigue damage which is common practice of shipbuilding industry.
- c) The criteria S-N curves are based on the fatigue test results of the fatigue resistant steels. Because the curves were drawn under all the test data, the degree of confidence of the said criteria S-N curves corresponds to 100%.
- d) The negative inverse slope of the criteria S-N curves are set based on the analysis of fatigue test results of the fatigue resistant steels. The same negative inverse slope of conventional steels (Haibach's modification) is applied to the fatigue resistant steels in the range of $N_f > 10^7$ (N_f : number of cycles to failure) since no fatigue test results of the fatigue resistant steels are available in the same range.
- e) The fatigue life of transverse non-load-carrying fillet welded joint and longitudinal fillet welded gusset of fatigue resistant steels is respectively set two (2) times longer than that of conventional steels at specific stress range corresponding to N_f of 2×10^6 cycles on the basic design S-N curve of UK HSE (D_{En}).
- f) The following two (2) kinds of welded joints are specified for evaluation since these kinds of joints are typical component joints for fatigue evaluation:

- 1) Transverse non-load-carrying fillet welded joint
- 2) Longitudinal fillet welded gusset.

For production testing, the kind of welded joint for fatigue test is to be agreed between the steel manufacturer and the purchaser, unless otherwise specified by the Classification Society, since the shipyard needs the fatigue test results for the specific type of welded joint considering the intended structural members to which the fatigue resistant steels are applied.

g) Dimensions of fatigue test specimens are specified with reference to the recognized standard and the relevant fatigue test specimens of the fatigue resistant steels tested. Thickness of test specimen is specified as 22mm since the thickness is considered as standard thickness of the fatigue test specimens in UK HSE (DEn).

(h) On the occasion of manufacturing approval, fatigue tests of conventional steels are required in addition to fatigue tests of fatigue resistant steels. The purpose of fatigue tests for conventional steels as well as fatigue resistant steels is to confirm that the fatigue strength of welded joints of the fatigue resistant steels is not improved by the welding procedures including bead profiles.

i) For stress range of fatigue test, 70N/mm^2 and 150N/mm^2 are specified as representative stress ranges of the criteria S-N curves. On the occasion of manufacturing approval, three (3) additional stress ranges are required for the fatigue test in order to enhance the reliability of the fatigue test results. Stress condition of fatigue test for transverse non-load-carrying fillet welded joint is specified by the stress range and the maximum stress of the specified minimum yield strength of the test steel, whereas that of longitudinal fillet welded gusset is specified by the stress range and the stress ratio, considering that fatigue test specimens of transverse non-load-carrying fillet welded joint tend to have lesser welding residual stress compared with that of actual welded structures.

j) The specified criteria S-N curves are only intended to be used for the purpose of approval of fatigue resistant steels, and not intended to be used for design approval purpose to determine the fatigue life of structures which utilise these steels, since the S-N curves intended for design approval purpose should be established by each Classification Society based on the relevant expertise of the fatigue resistant steels for the design approval.

3. Source/derivation of the proposed IACS Resolution

None

4. Summary of Changes intended for the revised Resolution:

Not applicable

5. Points of discussions or possible discussions

None

6. Attachments if any

None

Recommendation No. 140 “Recommendation for safe precautions during Survey and Testing of Pressurized Systems”

Summary

As a result of a marine accident report Section G8 ‘Precautions while dealing with Pressure System’ now updated to highlight the need for caution when surveying or working in the vicinity of pressurised systems

Part A. Revision History

Version no.	Approval date	Implementation date when applicable
Rev.1 (Mar 2019)	25 March 2019	-
New (Jun 2015)	1 June 2015	-

- **Rev. 1 (Mar 2019)**

.1 Origin for Change:

Suggestion by IACS Members

.2 Main Reason for Change:

A member drew to the attention of the Panel the contents of an accident investigation report No.MO-2017-203 issued by the ‘The Transport Accident Investigation Commission’ (Commission) of the New Zealand Government. The report deals with bursting of a pressurised Nitrogen Cylinder caused by corrosion to the shell which resulted in a fatality.

.3 List of non-IACS Member classification societies contributing through the TC Forum and/or participating in IACS Working Group:

None

.4 History of Decisions Made:

The Survey Panel discussed this matter under PSU18002. At the 27th Survey Panel Meeting, the members agreed recommendation 140 needs to be reviewed for possible updates. At the 28th Survey Panel Meeting, members agreed to update Para G8.1 of Rec 140 to highlight the need for caution when surveying or working in the vicinity of pressurised systems.

No TB is expected for the present revision.

.5 Other Resolutions Changes

None

.6 Any hinderance to MASS, including any other new technologies:

None

.7 Dates:

Original Task Proposal: 9th February 2018 by a panel member
Panel Approval: 7 March 2019 (Ref: PSU18002)
GPG Approval: 25 March 2019 (Ref: 19045_IGb)

• **New (June 2015)**

.1 Origin for Change:

Suggestion by IACS Members

.2 Main Reason for Change:

None – new document.

.3 List of non-IACS Member classification societies contributing through the TC Forum and/or participating in IACS Working Group:

None

.4 History of Decisions Made:

- Document was drafted with input from all EG/SOS members
- Document was reviewed and accepted by all EG/SOS members

See technical background document in Part B Annex 1.

.5 Other Resolutions Changes

None

.6 Dates:

Original Task Proposal to GPG: March 2013 by EG/SOS
EG/SOS Approval: 31 August 2014
GPG Approval: 1 June 2015 (Ref: 14174_IGI)

Part B. Technical Background

Technical Background (TB) documents for Rec.140:

Annex 1. **TB for New (June 2015)**

See separate TB document in Annex 1.

Note: *There are no separate Technical Background (TB) documents for Rev.1 (Mar 2019)*

Technical Background document for Rec. 140 (New, June 2015)

1. Scope and objectives

The proposed Recommendation provides guidance for IACS societies when establishing procedures for the witnessing of pressure tests by class society personnel. The Recommendation has been developed to promote the safety of class society personnel when conducting inspections of items and systems under pressure. It applies to survey activities carried out on existing vessels, at new construction, in repair yards and at vendors' fabrication shops and facilities. Societies may recommend the measures outlined in the Guidelines as applicable and also should meet any relevant occupational safety and health legislative requirements in place at locations where work is conducted.

2. Engineering background for technical basis and rationale

The marine industry continues to have relevant incidents and even fatalities when personnel are dealing with Pressure Tests and Pressurized Items.

IACS has, until now, not had any specific requirements placed on members regarding these activities; this Recommendation provides guidance for surveyors and industry.

The recommendations in this document are being used by one or more of the member societies and have been found to be practical.

3. Source/derivation of the proposed IACS Resolution

- EG member expertise
- EG member internal procedures and requirements
- See also referenced documents in the Guidelines

4. Summary of Changes intended for the revised Resolution:

This is the original draft resolution. No changes are intended at this point.

5. Points of discussions or possible discussions

- The document was initially assigned to a small group who completed the draft during first half of 2014 and the Chairman submitted the initial draft to all EG members, by July of 2014.
- The document was subject to various reviews and comments until the end of August 2014. The Guidelines are based upon recognized standards and did not cause any relevant controversy during the process.
- All members have participated, by emails and telecom, in the review of the document that was brought into completion of a final draft.

6. Attachments if any

None

Recommendation No. 141 “Guidelines for the Assessment of Safety Aspects at Workplace”

Part A. Revision History

Version no.	Approval date	Implementation date when applicable
New (July 2015)	12 July 2015	-

- **New (July 2015)**

1 Origin for Change:

- Suggestion by IACS Member

.2 Main Reason for Change:

Surveyors continue to face significant occupational safety and health hazards as they undertake their work on third party sites. This informative document is intended to increase awareness of health and safety hazards to class Surveyors and also the maritime industry.

.3 List of non-IACS Member classification societies contributing through the TC Forum and/or participating in IACS Working Group:

None

.4 History of Decisions Made:

- Document was drafted with input from all EG members
- Document was reviewed and accepted by all EG members
- Document was commented on by Survey Panel.
- EG SoS members reviewed comments of Survey Panel.
- Document was updated to Draft Rev 1 on 16th April 2015.
- Document title changed to “Guidelines for the Assessment of Safety Aspects at Workplace ”

.5 Other Resolutions Changes

None

.6 Dates:

Original Task Proposal to GPG: March 2013 by EG/SOS
 EG/SOS Approval: 31 December 2014
 GPG Approval: 12 July 2015 (Ref: 14210_IGi)

Part B. Technical Background

Technical Background (TB) documents for Rec.141:

Annex 1. TB for New (July 2015)

See separate TB document in Annex 1.

Technical Background document for Rec. 141 (New, July 2015)

1. Scope and objectives

The proposed Recommendation provides guidance for IACS societies when establishing procedures for the "Guidelines for Shipyards Health & Safety Assessment". The Recommendation has been developed to promote the safety of class society personnel when conducting inspections at the Shipyards. It applies to survey activities carried out at new construction yards and repair yards. Societies may recommend the measures outlined in the Guidelines as applicable and also should meet any relevant occupational safety and health legislative requirements in place at locations where work is conducted.

2. Engineering background for technical basis and rationale

The marine industry continues to have relevant incidents and even fatalities when personnel are working in Shipyards. Unfortunately, this may include CS's surveyors. IACS has, until now, not had any specific requirements placed on members regarding these activities; this Recommendation provides guidance for surveyors and industry. The recommendations in this document are being used by one or more of the member societies and have been found to be practical.

3. Source/derivation of the proposed IACS Resolution

- EG member expertise
- EG member internal procedures and requirements
- See also referenced documents in the Guidelines

4. Summary of Changes intended for the revised Resolution:

This is the original draft resolution. No changes are intended at this point.

5. Points of discussions or possible discussions

- The document was initially assigned to a small group who completed the draft by October 2014 and the Chairman submitted the initial draft to all EG members, by beginning of November 2014.
- The document was subject to various reviews and comments until the end of December 2014. The Guidelines are based upon recognized standards and did not cause any relevant controversy during the process.
- All members have participated, by emails and telecom, in the review of the document that was brought into completion of a final draft.

6. Attachments if any

None

Recommendation No.142 “LNG Bunkering Guidelines”

Part A. Revision History

Version no.	Approval date	Implementation date when applicable
New (June 2016)	22 June 2016	-

- **New (June 2016)**

.1 Origin for Change:

- Suggestion by IACS member

.2 Main Reason for Change:

As a consequence of rapid technological and operational developments in using LNG as a fuel for cargo and passenger ships, IACS Council agreed, as a part of the IACS strategy plan, to develop LNG bunkering guidelines based on international/national standards as well as relevant and available Class documents, in order to enhance and promote the safety of ships undertaking LNG bunkering operations and to be made available to the industry.

.3 List of non-IACS Member Classification Societies contributing through the TC Forum and/or participating in IACS Working Group:

None

.4 History of Decisions Made:

The draft Recommendation was circulated to relevant industry partners in December 2015 for their review and comments. GPG re-activated the Project Team which developed Recommendation 142 with a task to review received proposals, suggestions and comments and incorporate them where seemed appropriate and necessary.

.5 Other Resolutions Changes

None

.6 Dates:

Original Proposal: May 2014 by SC/Strategy
 Panel Approval: 2 June 2016 (Ref: PM14915)
 GPG Approval: 22 June 2016 (Ref: 14102_IGr)

Part B. Technical Background

List of Technical Background (TB) documents for Rec.142:



Note: *There is no Technical Background (TB) document available for New (June 2016).*

Recommendation No.143

“Recommended procedure for the determination of contents of metals and other contaminants in a closed fresh water system lubricated stern tube”

Part A. Revision History

Version no.	Approval date	Implementation date when applicable
New (Oct 2015)	9 Oct 2015	-

- **New (Oct 2015)**

.1 Origin for Develop:

- Other (*Suggestion by GPG*)

.2 Main Reasons for Develop:

Following the issue of the approved revision 3 of UR Z21 related to the propeller shaft surveys, GPG tasked the Survey Panel to draft a new recommendation dealing with the procedures for the “fresh water sample test” related to the lubricating media of the propulsion shafts lubricated by fresh water in closed loop.

.3 List of non-IACS Member classification societies contributing through the TC Forum and/or participating in IACS Working Group:

None

.4 History of Decisions Made:

Survey Panel started the discussion under the task 15005 by making reference to the IACS Recommendation 36, dealing with the procedure for the determination of contents of metals and other contaminants in stern tube lubricating oil, and concurred that the structure of the new recommendation should be based on this.

A first draft was prepared and examined with the cooperation of the Members who has the greater experience on these propulsion systems using fresh water in closed loop.

At the 21st Panel meeting the frame of the drafted guideline has been discussed by leaving aside the particular relevant to the elements to be verified during the test of the samples and their allowable content limits. The Panel tasked the Members having the experience on these systems to suggest, according to their backgrounds and feedbacks, the list of elements to be examined and the related allowable content limits in to the lubricant media.

Machinery Panel Members provided their comments that have been dealt with by the Survey Panel Members. The editorial comments have been analysed and applied as appropriate.

Finally Survey Panel agreed the final draft of the new recommendation during the 22nd Survey Panel Meeting.

.5 Other Resolutions Changes:

Not Applicable

.6 Dates:

Panel Approval: *15 September 2015 (Ref: PSU15005)*

GPG Approval: *9 October 2015 (Ref: 12080_IGo)*

Part B. Technical Background

List of Technical Background (TB) documents for Rec.143:

Annex 1. **TB for New (Oct 2015)**

See separate TB document in Annex 1.



Technical Background (TB) document for Rec.143 (New Oct 2015)

1. Scope and objectives

Develop a new Recommendation related to the procedure for the determination of contents of metals and other contaminants in a closed fresh water system lubricated stern tube.

2. Engineering background for technical basis and rationale

With the revision 3 of UR Z21 it has been introduced the surveys of propulsion systems using as a lubricant media the Fresh Water operating in a close loop system. Among other things the survey criteria expects that every six months the lubricant media is submitted to test in order to verify the possible contents of contaminants and to confirm the allowable limits of these. This is required for survey Method 2 and survey Method 3, and possible extension surveys.

3. Source/derivation of the proposed IACS Resolution

Survey Panel Members, in consultation with their own Society's experts, backgrounds and feedbacks

Machinery Panel Members background and feedbacks

4. Summary of Changes intended for the revised Resolution

This is the original draft resolution. No changes are intended at this point.

5. Points of discussions or possible discussions

- The recommendation has been developed on the basis of the frame of IACS Recommendation 36 which deals with the procedure for the determination of contents of metals and other contaminants in stern tube lubricating oil
- The following parameters have been considered:
 - Metal contents
 - Corrosion inhibitors in fresh water
 - Salinity indicators
 - Contents of bearing and seal particles,
 - Data of records of fresh water make up in the systems
- The draft was subjected to an initial discussion and review by part of the Panel Members
- Subsequently Panel agreed to task the Members who have more experience on this matter to define the contaminants typical of these systems and set the allowable limits for these. In particular the following has been defined:
 - Metal that might contaminate the water: Iron, Chromium, Nickel, Copper, Silicon. Other metal such as Lead, Tin, Aluminum, Manganese have not

been considered since these are the material of white metal bearings used in conjunction to an oil lubricated system.

- Salinity indicators: Chloride contents and Sodium

For what concern the corrosion inhibitors no value has been set since it depends by the indication of the system Manufacturer. Anyway it has been set the minimum value of the fresh water PH (or alkalinity indicator) that should be not less than 11 in order to grant the shaft material passivation against the oxygen contained in the water.

It is worth to note that the following consideration on metals contents and PH has been provided by one expert Member in order to justify the choices:

- The metals chosen were those likely to be constituents of a propulsion shaft. Tin and Lead were not included since these are predominantly white metal bearing constituents which do not apply in case of synthetic bearings in closed loop water based systems.

Following discussion with our Materials specialists it was suggested that one difference between oil and water based systems might be a higher amount of adsorbance on a water based system – ie. The sample we get might be more misleading – greater margin for error.

Adsorption is the adhesion of atoms, ions, or molecules from a gas, liquid, or dissolved solid to a surface. This process creates a film of the adsorbate on the surface of the adsorbent. It is considered that there might be more particles adhering to the pipework and being taken out of the flow system in a water based system rather than an oil based system, and hence the figures based upon Rec 36 were strategically adjusted to attempt to take account of this phenomenon.

This explains the reduction in wear elements suspended in the system and also explain the minor reduction of the upper limits for salinity.

- At pH>10 corrosion of metals is minimal, hence it has been set the reference value at pH=11. The lower pH limit shall be maintained at 11 to ensure desired passivation of the metal surfaces. Passivation of steel in a medium with moderate to high level of dissolved oxygen would require a comparatively higher level of alkalinity

6. Attachments if any

None.

Recommendation No.144 "Inspection of ship's side valves"

Part A. Revision History

Version no.	Approval date	Implementation date when applicable
New (Feb 2016)	10 February 2016	-

- **New (Feb 2016)**

.1 Origin for Change:

- Suggestion by IACS member

.2 Main Reason for Change:

A Member drew the attention of the Panel to the contents of an accident investigation report No. 14/2015 issued by the 'Marine Accident Investigation Branch' (MAIB) of the UK Government. The report deals with the flooding of the engine room caused by the malfunctioning of the closing mechanism of a ship's side valve.

.3 List of non-IACS Member Classification Societies contributing through the TC Forum and/or participating in IACS Working Group:

None

.4 History of Decisions Made:

The Survey Panel started the discussion under the task 15038 by making reference to the report of the incident and examined the IACS resolutions relating to the inspection of the ship's side valves and their actuating mechanisms: UR Z3 and UR Z7. Members noted that both unified requirements do not deal with the matter in detail.

Members discussed by correspondence and during the 22nd meeting whether it was necessary to introduce a modification to UR Z7 to require the inspection of the ship's side valves and their actuating mechanisms or to issue a dedicated new recommendation. Members agreed to address the matter in depth and separate from UR Z7.

As consequence of the discussion Members agreed to draft a new recommendation which details the minimum survey criteria for the ship's side valves and their actuating mechanisms.

Finally Survey Panel agreed the final draft of the new recommendation during the 22nd Survey Panel Meeting.

No TB has been prepared.

.5 Other Resolutions Changes

None

.6 Dates:

Original Proposal: 17 August 2015 made by IACS Member
Panel Approval: 21 January 2016 (Ref: PSU15038)
GPG Approval: 10 February 2016 (Ref: 16019_IGb)

Part B. Technical Background

List of Technical Background (TB) documents for Rec.144:



Note: *There is no Technical Background (TB) document available for New (Feb 2016).*

Recommendation No.145

“Recommendation for the Operation of Shore-based Emergency Response Services”

Part A. Revision History

Version no.	Approval date	Implementation date when applicable
New (May 2016)	18 May 2016	-

- **New (May 2016)**

.1 Origin for Change:

- Request by non-IACS entity (*EU DG-MOVE*)
- Suggestion by IACS member

.2 Main Reason for Change:

Following discussion at C72 as well as discussions with DG-MOVE, it was concluded that a document addressing the minimum support services for vessels in need of operational technical support (including vessels in need of a Port of Refuge) was desired. The primary intention of the expected technical support is to consider structural strength and stability (including down-flooding) and consideration of damage to the hull envelope as well as environmental aspects.

.3 List of non-IACS Member Classification Societies contributing through the TC Forum and/or participating in IACS Working Group:

None

.4 History of Decisions Made:

Each Hull Panel Member was requested to provide details of their respective Societies' emergency response capabilities. These capabilities were reviewed in order to establish the minimum capabilities required to both comply with relevant national and international regulations and guidelines as well provide effective and rapid technical assistance to a ship in a casualty situation.

.5 Other Resolutions Changes

None

.6 Dates:

Original Proposal: 03 February 2016 made by Hull Panel Chair
 Panel Approval: 12 April 2016 (Ref: PH16005)
 GPG Approval: 18 May 2016 (Ref: 14134_IGb)

Part B. Technical Background

List of Technical Background (TB) documents for Rec.145:

Annex 1. **TB for Original Resolution**

See separate TB document in Annex 1.



Technical Background (TB) document for Rec.145 (New May 2016)

1. Scope and objectives

Following discussion at C72 as well as discussions with DG-MOVE, it was concluded that a document addressing the minimum support services for vessels in need of operational technical support (including vessels in need of a Port of Refuge) was desired. The primary intention of the expected technical support is to consider structural strength and stability (including down-flooding) and consideration of damage to the hull envelope as well as environmental aspects.

2. Engineering background for technical basis and rationale

Each Hull Panel Member was requested to provide details of their respective Societies' emergency response capabilities. These capabilities were reviewed in order to establish the minimum capabilities required to both comply with relevant national and international regulations and guidelines as well provide effective and rapid technical assistance to a ship in a casualty situation.

3. Source/derivation of the proposed IACS Resolution

The relevant national and international standards which were considered are as follows:

- MARPOL Annex I, Regulation 37 – Shipboard oil pollution emergency plan (SOPEP)

All oil tankers of 5,000 tons deadweight or more shall have prompt access to computerised, shore-based damage stability and residual structural strength calculation programs.

- Shipboard marine pollution emergency plan for noxious liquid substances (SMPEP)

Stability and strength considerations: Great care in casualty response must be taken to consider stability and strength when taking actions to mitigate the spillage of oil or noxious liquid substance or to free the ship if aground. The Plan should provide the master with detailed guidance to ensure that these aspects are properly considered. Nothing in this section shall be construed as creating a requirement for damage stability plans or calculations beyond those required by relevant international conventions.

1. Internal transfers should be undertaken only with a full appreciation of the likely impact on the ship's overall longitudinal strength and stability. When the damage sustained is extensive, the impact of internal transfers on stress and stability may be impossible for the ship to assess. Contact may have to be made with the owner or operator or other entity in order that information can be provided so that damage stability and damage longitudinal strength assessments may be made. These could be made within the head office technical departments. In other cases, classification societies or independent organizations may need to be contacted. The Plan should clearly indicate who

the master should contact in order to gain access to these facilities. Additionally, in the case of ships certified to carry NLSs, consideration as to the compatibility of all substances involved such as cargoes, bunkers, tanks, coatings, piping, etc., must also be considered before such an operation is undertaken.

- Oil Pollution Act (OPA 90), CFR 155.240 – Damage stability information for oil tankers and offshore barges
 - (a) *Owners or operators of oil tankers and offshore oil barges shall ensure that their vessels have prearranged prompt access to computerised, shore-based damage stability and residual strength calculation programmes.*
 - (b) *Vessel baseline strength and stability characteristics must be pre-entered into such programmes and be consistent with the vessel's existing configuration.*
 - (c) *Access to shore-based programmes must be available 24 hours a day.*
 - (d) *At a minimum, the programme must facilitate calculation of the following:*
 - *Residual hull girder strength based on reported extent of damage*
 - *Residual stability when the vessel's compartments are breached*
 - *The most favourable off-loading, ballasting or cargo transfer sequences to improve residual stability, reduce hull girder stresses and reduce ground-force reaction.*
 - *The bending and shear stresses caused by pinnacle loads from grounding or stranding.*

- ISM Code: Regulation 8, Emergency Preparedness

8.1 The Company should identify potential emergency shipboard situations and establish procedures to respond to them.

8.2 The Company should establish programmes for drills and exercises to prepare for emergency actions.

8.3 The safety management system should provide for measures ensuring that the Company's organisation can respond at any time to hazards, accidents and emergency situations involving its ships.

- SOLAS, Chapter II-1, Part B-1, Regulation 8-1 – System capabilities and operational information after a flooding casualty on passenger ships

For the purpose of providing operational information to the Master for safe return to port after a flooding casualty, passenger ships constructed on or after 1 January 2014 shall have:

1. onboard stability computer, or

2. shore-based support,

based on guidelines developed by the Organization

- MSC Circular 1400 – Guidelines on Operational Information for Masters of Passenger Ships for Safe Return to Port by Own Power or Under Tow

Owners or operators of passenger ships should ensure that their ships have prearranged, prompt access to computerized, shore-based damage stability and residual structural strength calculation programs. The output should be within the tolerances specified in the Guidelines for the approval of stability instruments (MSC.1/Circ.1229). Access to the shore-based calculation program should be available 24 hours a day. The computer model of the ship and its subdivision arrangements should be input at the commencement of the contract.

There should be a contract for the supply of shore-based support at all times during the validity of ship certification.

Shore-based support should be operational within one hour; whereby operational means the ability to input details of the conditions of the ship as instructed.

Shore-based support should be manned by adequately qualified persons with regard to stability and ship strength; no less than two qualified persons should be available to be on call at all times.

At least two independent computers capable of carrying out stability and global strength calculations should be available at all times.

4. Summary of Changes intended for the revised Resolution:

None

5. Points of discussions or possible discussions

None

6. Attachments if any

None

Recommendation No. 146

“Risk assessment as required by the IGF Code”

Part A. Revision History

Version no.	Approval date	Implementation date when applicable
New (Aug 2016)	10 August 2016	-

- **New (Aug 2016)**

.1 Origin for Change:

- Request by non-IACS entity (INTERTANKO)

.2 Main Reason for Change:

The IGF Code states that the techniques used as part of the risk assessment shall be “acceptable”, “recognised” and “documented to the satisfaction of the Administration” (IGF Code Part A, 4.2.3). However, the Code makes no mention of: (1) ‘what is acceptable’; (2) ‘what level of recognition is required’; and (3) ‘what documentation would be satisfactory’. By addressing these three items IACS would provide a common platform for the risk assessment. This would promote consistency in application, reporting and judgements made on the level of risk. This Recommendation is aimed to provide for consistency in the application of risk assessment techniques and criteria in respect of the IGF Code requirement for risk assessment.

.3 List of non-IACS Member Classification Societies contributing through the TC Forum and/or participating in IACS Working Group:

None.

.4 History of Decisions Made:

Form A and Form 1 were approved by 13120_IGd dated 31 October 2014. The ‘Recommendation’ was developed by the project team via correspondence and a workshop between January 2015 and April 2016 (workshop, 24-25 March 2015). The draft ‘Recommendation’ was submitted to Machinery Panel for review on 4 September 2015 and subsequent revisions incorporated, as directed by the Panel.

.5 Other Resolutions Changes

None.

.6 Dates:

Original Proposal: 12 July 2013 Made by GPG (INTERTANKO’s request)
 Panel Approval: 9 May 2016 (Ref: PM13915)
 GPG Approval: 10 August 2016 (Ref: 13120_IGk)

Part B. Technical Background

List of Technical Background (TB) documents for Rec. 146:

Annex 1. **TB for New (Aug 2016)**

See separate TB document in Annex 1.



Technical Background (TB) document for Rec. 146 (New Aug 2016)

1. Scope and objectives

The IGF Code states that the techniques used as part of the risk assessment shall be *"acceptable", "recognised" and "documented to the satisfaction of the Administration"* (IGF Code Part A, 4.2.3). However, the Code makes no mention of: (1) 'what is acceptable'; (2) 'what level of recognition is required'; and (3) 'what documentation would be satisfactory'. By addressing these three items IACS would provide a common platform for the risk assessment which would promote consistency in application, reporting and judgements made on the level of risk.

The objective is to provide guidance to promote consistent application of risk assessment approaches in relation to the IGF Code requirements. The scope covers the use of low-flashpoint fuel; supply, storage, preparation and use.

2. Engineering background for technical basis and rationale

The recommended risk assessment approach is based on established practice modified to the specific application required by the IGF Code.

3. Source/derivation of the proposed IACS Resolution

Reference was made to:

1. Risk management: Risk assessment techniques. IEC/ISO 31010:2009.
2. Petroleum and natural gas industries - Offshore production installations - Guidelines on tools and techniques for hazard identification and risk assessment. EN ISO 17776:2002.
3. Guidance on performing risk assessment in the design of onshore LNG installations including the ship/shore interface. ISO/TS 16901:2015.
4. Risk and emergency preparedness assessment. NORSOK Standard Z-013, Edition 3, October 2010.
5. Methods for determining and processing probabilities. CPR 12E, 1997/2005.
6. Guidelines for chemical process quantitative risk analysis. Centre for Chemical Process Safety, American Institute of Chemical Engineers, Second Edition, 2000.
7. Marine risk assessment. Health & Safety Executive, 2001.

4. Summary of Changes intended for the revised Resolution:

N/A

5. Points of discussions or possible discussions

a. Scope issue

There was a comment to re-evaluate the status, scope and objective of the document considering the decision made at MSC 95 to narrow down the scope of a risk assessment to a number of specific areas (5.10.5, 5.12.3, 6.4.1.1, 6.4.15.4.7.2, 8.3.1.1, 13.4.1, 13.7 and 15.8.1.10 and paragraphs 4.4 and 6.8 of the annex to the IGF Code). However, in spite of the exemptions for LNG (Part A-1), a risk assessment is a general requirement of the IGF Code for all low-flashpoint fuels (Part A, 4.2.1), and therefore Machinery Panel concurred to keep the original scope and objective of

the document to provide a framework to promote consistency in risk assessment to cover all potential low-flashpoint fuels.

b. Format issue

From discussions at and after MSC 95, it was revealed that there was still a degree of uncertainty and even different views among Flag Administrations as to the detailed scope and required depth of analysis. Against this background, it was not considered prudent for IACS to issue a UR this time. Instead, it was agreed to publish the document as a Recommendation this time and later to consider upgrading it to a UR with necessary amendments.

6. Attachments if any

N/A

Recommendation No.147

“Type Approval Certificate of Internal Combustion Engine”

Part A. Revision History

Version no.	Approval date	Implementation date when applicable
New (Oct 2016)	31 October 2016	-

- **New (Oct 2016)**

.1 Origin for Change:

- Request by non-IACS entity (CIMAC WG2)

.2 Main Reason for Change:

This task was triggered by CIMAC WG2 with their specific proposal of CL-15-004 proposing contents for a Type Approval Certificate cover page. The rationale behind the proposal is that existing Type Approval Certificates for IC engines issued by IACS member societies contain remarkable contents, which are leading to more and more discussions by local Class representatives and by the engine builders with regard to the interpretation. Furthermore, some certificates contain a lot of critical information not intended to disclose to third parties.

A harmonised Type Approval Certificate Form is therefore requested to be developed in order to define agreed contents to be contained and consequently to enable the TACs to be shown to any third parties without disclosure of critical information.

.3 List of non-IACS Member Classification Societies contributing through the TC Forum and/or participating in IACS Working Group:

None

.4 History of Decisions Made:

- CIMAC proposal was initially made at the 9th Joint Meeting between IACS MP and CIMAC WG2 on 3 September 2013 and CIMAC WG2's proposal CL-15-004, a base for this task, was received on 18 March 2015.
- Form A was noted by GPG and subsequently finalised and archived by Permsec by 15117_IAa dated 3 July 2015.
- A copy of draft Type Approval Certificate was forwarded to CIMAC WG2 for comments on 23 December 2015 and finally returned to the Panel with CIMAC comments on 26 February 2016.
- Draft TAC was agreed by the Panel at the 24th panel meeting held on 6-9 September 2016.

.5 Other Resolutions Changes

None

.6 Dates:

Original Proposal: 3 September 2013 by CIMAC WG2
Panel Approval: 7 October 2016 (Ref: PM15903)
GPG Approval: 31 October 2016 (Ref: 15117_IGc)

Part B. Technical Background

List of Technical Background (TB) documents for Rec. 147:

Note:

1) *There is no Technical Background (TB) document available for New (Oct 2016).*

Recommendation No.148

“Survey of liquefied gas fuel containment systems”

Summary

This revision is to amend item 1.2 of Rec.148, with the wording ‘without access openings’ being inserted.

Part A. Revision History

Version no.	Approval date	Implementation date when applicable
Rev.1 (Mar 2020)	10 March 2020	-
New (Jan 2017)	18 January 2017	-

• Rev. 1 (Mar 2020)

.1 Origin for Change:

- Suggestion by IACS member

.2 Main Reason for Change:

As proposed by one member, Survey Panel reviewed the background of paragraph 1.2 of IACS Rec.148, upon the question from shipowners why the vacuum insulated independent fuel storage tanks of type C need not be examined internally while the other types of independent fuel storage tanks of type C need to be examined internally as per the item 1.2 of IACS Rec.148, and agreed to consider further revision to Rec.148.

.3 List of non-IACS Member classification societies contributing through the TC Forum and/or participating in IACS Working Group:

None

.4 History of Decisions Made:

Survey Panel recalled that under GPG task No.16003, the Rec.148 was finalized with deletion of the wording ‘without access openings’.

For avoiding any confusion by the industries, Survey Panel members concurred with the following views:

1. Internal examination of vacuum insulated independent fuel storage tanks of type C are normally exempted due to:
 - a. Normally no access
 - b. Length of time required to re-establish the vacuum

2. All other types of LNG tanks and pressure vessels are normally internally examined at five year intervals.

3. The wording 'without access openings' should be recovered into the item 1.2 of Rec.148 as proposed by Survey Panel in 16003_PYb.

The revision to item 1.2 of Rec.148, with the wording 'without access openings' being inserted, was agreed by the panel.

No TB is expected for this revision.

5 Other Resolutions Changes:

None

6 Any hinderance to MASS, including any other new technologies:

None

7 Dates:

Original Proposal: 2 August 2019 (proposed by one Member)
Panel Approval: 13 February 2020 (Ref: 20031_Pya)
GPG Approval: 10 March 2020 (Ref: 20031_IGb)

• New (Jan 2017)

.1 Origin for Change:

Based on IMO Regulation (IGF Code)

.2 Main Reason for Change:

During discussions at the September 2015 Survey Panel Meeting, the members supported developing common survey requirements for gas fuelled ships considering the implementation of the IGF Code on ships constructed on or after 1 January 2017. During the development of the requirements for the survey/inspection plan of the gas fuel containment systems, it was determined that the requirements of UR Z16 could be applied.

.3 List of non-IACS Member Classification Societies contributing through the TC Forum and/or participating in IACS Working Group:

None.

.4 History of Decisions Made:

The Survey Panel formed a Project Team to review the IGF Code to develop periodical survey requirements for the gas fuel systems. The Form A and Form 1 were approved by GPG on 10 February 2016. The project team held a workshop in Genoa on 14 March

2016 to develop the draft UR which was progressed through correspondence. During the development of the requirements for the survey/inspection plan of the gas fuel containment systems, it was determined that the requirements of UR Z16 could be applied. Rather than including the requirements in the UR, the team decided it was better to issue the requirements as Recommendation.

The project team submitted a draft Recommendation to the Survey Panel on 29 June 2016 for their approval.

The Survey Panel raised comments which were sent to the project team for consideration on 9 August 2016. The project reviewed the comments and submitted a revised draft Recommendation to the Survey Panel on 31 August 2016. The draft Recommendation was discussed and finalized at the Survey Panel Meeting held 7 – 9 September.

No technical background is expected.

.5 Other Resolutions Changes

None.

.6 Dates:

Original Proposal: 17 September 2015 Made by: PT PSU27/2016

Panel Approval: 09 September 2016 (Ref: PSU15009)

GPG Approval: 18 January 2017 (Ref: 16003_IGf)

Part B. Technical Background

List of Technical Background (TB) documents for Rec.148:

Note:

1) There is no separate Technical Background (TB) document for New (Jan 2017) and Rev.1 (Mar 2020).

Recommendation No. 149 “Guidance for applying the requirements of 15.4.1.2 and 15.4.1.3 of the IGC Code (on ships constructed on or after 1 July 2016)”

Part A. Revision History

Version no.	Approval date	Implementation date when applicable
New (May 2017)	16 May 2017	-

- **New (May 2017)**

.1 Origin for Change:

- Revision of the IGC Code

.2 Main Reason for Change:

The International Code for the Construction and Equipment of Ships Carrying Liquefied Gases in Bulk (IGC Code) was revised.

.3 List of non-IACS Member Classification Societies contributing through the TC Forum and/or participating in IACS Working Group:

None.

.4 History of Decisions Made:

A project team was formed to evaluate a HAZID carried out by GTT on cargo tanks' filling limits to address any anticipated amendments expected to occur after the revised IGC Code enters into force and to consider the development of any appropriate Unified Interpretation/understanding with regard to filling limits. The Project Team held a workshop on 2/3 February 2016 and drafted a revision to IACS Recommendation 109. It was decided that since the revised IGC Code specifically stated that isolated vapour pockets were prohibited, that Rec 109 would be revised to apply to the “old” IGC Code and a new Recommendation would be issued for cargo tank filling limits under the revised IGC Code. Since the revised IGC Code specifically prohibits increasing the filling limit above the default limit, the new Recommendation only addresses the elements from the Rec 109 which still apply; specifically, determining that the PRV inlet remains in vapour space and the calculation of allowances. The revision was submitted to the Safety Panel on 21 March 2016 for their review and comments.

The Safety Panel reviewed and agreed with the output of the PT.

No TB will be issued.

.5 Other Resolutions Changes

None.

.6 Dates:

Original Proposal: 14 July 2014 made by Safety Panel & PT

Panel Approval: 31 March 2017 (Ref: SP14011a)

GPG Approval: 16 May 2017 (Ref: 15097_IGh)

Part B. Technical Background

List of Technical Background (TB) documents for Rec. 149:

Note:

1) There is no separate Technical Background (TB) document for New (May 2017).

Recommendation No. 150 “Vapour pockets not in communication with cargo tank vapour / liquid domes on liquefied gas carriers”

Part A. Revision History

Version no.	Approval date	Implementation date when applicable
New (May 2017)	16 May 2017	-

- **New (May 2017)**

.1 Origin for Change:

- Revision of the IGC Code

.2 Main Reason for Change:

The International Code for the Construction and Equipment of Ships Carrying Liquefied Gases in Bulk (IGC Code) was revised.

.3 List of non-IACS Member Classification Societies contributing through the TC Forum and/or participating in IACS Working Group:

None.

.4 History of Decisions Made:

A project team was formed to evaluate a HAZID carried out by GTT on cargo tanks' filling limits to address any anticipated amendments expected to occur after the revised IGC Code enters into force and to consider the development of any appropriate Unified Interpretation/understanding with regard to filling limits. The Project Team held a workshop on 2/3 February 2016 and drafted this new Recommendation. During their discussions, it was determined that even though the IGC Code states that the PRVs should be in the vapour phase under conditions of 15° list and 0.015L trim and presumes that no isolated vapour pockets are formed within this range in principle, this scenario can occur at other trim and list values based upon the filling level of the tank since the ship is designed to survive a damage condition up to 30° of list. The team felt that owners should be alerted of this situation and to consider addressing it through emergency procedures.

The revision was submitted to the Safety Panel on 21 March 2016 for their review and comments with a recommendation to consider making it a Unified Interpretation. This was debated by the Safety Panel and comments were sent back to the Project Team. The team recommended that it remain a Recommendation and clarified that the emergency procedures were not a substitute for requirement 15.4.1.1 when determining the increased filling limits. The Safety Panel accepted the recommendation of the Project Team.

No TB will be issued.

.5 Other Resolutions Changes

None.

.6 Dates:

Original Proposal: 14 July 2014 made by Safety Panel & PT
Panel Approval: 31 March 2017 (Ref: SP14011a)
GPG Approval: 16 May 2017 (Ref: 15097_IGh)

Part B. Technical Background

List of Technical Background (TB) documents for Rec. 150:

Note:

1) *There is no separate Technical Background (TB) document for New (May 2017).*

Recommendation No. 151

'Recommendation for petroleum fuel treatment systems for marine diesel engines'

Summary

In Rec.No.151 (Rev.2), changes have been made to reflect 'non-mandatory' nature of the document and improve technical consistency of recommendation.

Part A. Revision History

Version no.	Approval date	Implementation date when applicable
Rev.2 (Nov 2023)	17 November 2023	-
Rev.1 (Nov 2020)	19 November 2020	-
New (July 2017)	17 July 2017	-

• Rev.2 (Nov 2023)

1 Origin of Change:

- Other (Periodical review to ascertain that this Recommendation is suitable for the latest developments in technology)

2 Main Reason for Change:

This task is a follow-up action to consider substantive modifications based upon Members comments raised during development of Rev.1 of this Recommendation.

3 List of non-IACS Member classification societies contributing or participating in IACS Working Group:

None

4 History of Decisions Made:

The existing paragraphs of REC 151 have been improved to ascertain that the Recommendation is suitable for the latest developments in technology. Improvement technical consistency of recommendation have been done by inclusion of applicable oil fuel standards, centrifuges performance and flow rate certification testing standard and appropriate technical terms.

5 Other Resolutions Changes:

None

6 Any hinderance to MASS, including any other new technologies:

None

7 Dates:

Original Proposal:	3 December 2020	(Ref: PM19950_IMm)
Panel Approval:	26 October 2023	(Ref: PM19950_IMzc)
GPG Approval:	17 November 2023	(Ref: 20119_IGg)

• Rev.1 (Nov 2020)

1 Origin of Change:

- Survey Panel Comments and GPG request submitted to Machinery Panel

2 Main Reason for Change:

Although IACS Rec. No. 151(July 2017) '*Recommendation for petroleum fuel treatment systems for marine diesel engines*' is a non-mandatory IACS document, at various instances it contained 'mandatory' language, such as paragraphs relating to requirements, to approve plans and to survey activities.

In view of the above, it has been agreed by Machinery and Survey Panel Chairs to take suitable measures to eliminate the risk of potential problems during future audits and, in Rev.1 of Rec. No.151, changes have been made to reflect the 'non-mandatory' nature of the document.

3 List of non-IACS Member classification societies contributing or participating in IACS Working Group:

None

4 History of Decisions Made:

Rec.151(Rev.1) has been developed by correspondence and was agreed in Nov 2020.

5 Other Resolutions Changes:

None

6 Any hinderance to MASS, including any other new technologies:

None

7 Dates:

Original Proposal:	09 December 2019	Made by: GPG
Panel Approval:	02 November 2020	(Ref: 20119_PMc)
GPG Approval:	19 November 2020	(Ref: 20119_IGd)

• **New (July 2017)**

1. Origin of Change:

- Other (Questions from industry)

2. Main Reason for Change:

- a. Questions from the industry as a result of an apparent increase in fuel quality related failures (see PM11005) and the later discussions within the machinery panel (see PM11906) revealed a need to establish minimum requirements for the treatment of fuel on board ships.
- b. Questions from Intertanko concerning verification of the ability of fuel oil pumps to work with marine fuels with a sulphur content of 0.10% and a minimum viscosity of 2 cSt (see PM13925). Especially focus is on compliance of fuel oil pumps used for HFO with marine fuels with a sulphur content of 0.10% and low viscosity.

3. List of non-IACS Member Classification Societies contributing through the TC Forum and/or participating in IACS Working Group:

None

4. History of Decisions Made:

Recommendation No. 151 has been developed by correspondence and was agreed in July 2017.

5. Other Resolutions Changes

None

6. Dates:

Original Proposal:	4 September 2014	(Ref: 11002_PMe)
Panel Approval:	28 June 2017	(Ref: PM11906)
GPG Approval:	17 July 2017	(Ref: 11002_IGt)

Part B. Technical Background

List of Technical Background (TB) documents for Rec 151:

Annex 1. **TB for New (July 2017)**

See separate TB document in Annex 1.

Annex 2. **TB for Rev.1 (Nov 2020)**

See separate TB document in Annex 2.

Annex 3. **TB for Rev.2 (Nov 2023)**

See separate TB document in Annex 3.



Technical Background (TB) document for Rec 151 (New July 2017)

1. Scope and objectives

It is recognized that there is a disparity between the quality of fuel bunkered (ISO 8217) and the fuel quality requirements of some machinery equipment (e.g. engines) manufacturers and as such, on-board fuel treatment needs to be considered as an essential service since incorrect or insufficient treatment has been identified as an increasingly common cause of failure of machinery providing essential services.

Additionally, it has been highlighted by an industry body that there is no documentation provided by manufacturers to state that their HFO pumps are suitable to run on fuels with a sulphur content of 0.10% and a minimum viscosity of 2 cSt and such confirmation needs to be provided in order to make the capabilities of the pump clear to interested stakeholders.

For these reasons, the Machinery Panel has decided to develop a relevant Recommendation through PT11906. The benefit of undertaking the task is to provide recommendations for shipyards and ship owners for the treatment of fuel oil on board ships to provide for the safe operation of oil fuelled machinery and to provide appropriate test procedures for fuel oil pump manufacturers to confirm the ability of HFO fuel oil pumps operation with marine fuels with a sulphur content of 0.10% and low viscosity.

2. Engineering background for technical basis and rationale

This Recommendation has been developed taking into consideration PT members Societies' existing technical and verification requirements, and, where there are no relevant rules, information from industry bodies, relevant technical standards and each PT member's experience and knowledge. The specific procedures for developing the Recommendation were as follows:

- a) To establish minimum requirements based on collected existing members' requirements;
- b) To agree a common system representation with respect to the layout, processing and monitoring, from the bunkering manifold and on board fuel tanks to the engines;
- c) To identify possible gaps within the collected requirements and identify where additional requirements are needed;
- d) To identify and develop appropriate threshold criteria;
- e) To develop an appropriate framework for the new Recommendation (i.e. 1. Application, 2. Definition, etc.); and
- f) To develop a draft Recommendation based on identified gaps and threshold criteria.

In order to further utilise the systems engineering concept outlined at the start of the task and thus ensure that in respect of developing requirements related to fuel quality,

the fuel system was considered holistically, it was deemed appropriate to adopt a uniform structure to the Recommendation that considered common categories of requirements at each system level. In this respect, ISO/IEC/IEEE 29148:2011, 'Systems and software engineering — Life cycle processes — Requirements engineering' was used to help form the basis. In consideration of the common system representation in b) above, requirements were therefore logically derived at fuel system level and then at the level of each key piece of equipment.

Having considered each of the members' requirements, it was identified that whilst a number of engine manufacturers and CIMAC provide guidelines for fuel quality expected for safe and reliable operation of engines, Class Rules do not currently define such criteria. Requirements have therefore been proposed at the fuel system level in order to achieve a fuel quality for use by the engine. A maximum cat-fine level of 10 ppm is defined in source 2 below which is also consistent with the range given in source 6. However, it is not only the quantity of cat-fines which is of consequence but also the particle size and as a result distribution of particle size in terms of maximum percentages of certain sizes have been proposed. The maximum water limit proposed is also aligned with source 6.

Whilst it is clearly important to define the output of the system in order to achieve engine manufacturer's recommendations, this alone does not make it possible to derive the system's equipment requirements as the input to the system is undefined. In this respect it has therefore been proposed that the standard of bunkered fuel must be considered at the outset, with industry practice typically being to specify fuels that meet the requirements of ISO 8217. However, flexibility has been given on the provision that the bunkered fuel quality requirements are agreed with the consumer manufacturer(s).

Another significant point of note is the inclusion of requirements for sampling points within the system. The PT has specified that it considers to be a minimum number of positions for sampling points in order to determine the fuel quality at specific points in the system and thus verify whether it and the components thereof are performing in accordance with the requirements. Requirements have been included to ensure that the sampling points are at positions that facilitate the drawing-off of fuel that is representative of that actually flowing through the equipment to the consumer, avoiding the potential to obtain samples from potentially stagnant areas, or areas that may be subject to sludge. The inclusion of requirements for provision of such sampling points is also consistent with some views expressed in MEPC.1/Circ. 864 '*Guidelines for on board sampling for the verification of the sulphur content of the fuel oil used on board ships.*'

It was then possible to derive equipment level requirements and these have been written for what are considered to be the core elements of the system in respect of fuel quality, i.e. fuel tanks, heaters, pumps, filters and centrifugal separators (purifiers).

In respect of fuel tanks, at least one member's existing requirements define high level geometrical and construction requirements to ensure sludge is directed away from suction points and to a drain point. This was also a recommendation in source 6. It was also considered appropriate to include requirements for heating of fuel in tanks; for distillate grades, lower temperature heating is often required in order to manage the fuel's cold flow properties and prevent blocking of filters, whilst for residual fuels, heating is required in order to achieve the appropriate viscosity for efficient separation.

In respect of other equipment within the fuel system, it has generally been necessary to avoid too much prescription in terms of the performance of the equipment as this is highly dependent upon the overall system design, recognising that the numbers of consumers, fuel tanks and types of fuel envisaged for use can have a significant impact on the design of specific elements.

One area where it was felt that more prescription was beneficial was for the purifiers as these are generally critical to achieving the necessary quality of fuel, particularly in respect of removing cat-fines and water. Whilst the separation capacity of the system is system dependent, it was recognised that much work has been undertaken over recent years in order to standardise the approach to measuring separator performance, thus providing control over a critical variable of the system.

As is noted by source 4, three key stakeholders from the fuel supplier community, the purifier manufacturer community and the end consumer community have collaborated to investigate the issue and develop an approach to dealing with them. A CEN Workshop Agreement for assessing the performance of separators was published in 2005 by the European Committee for Standardisation. This standard provides for a Certified Flow Rate which is defined as the flow rate in litres per hour, 30 minutes after sludge discharge, at which the separation efficiency of the separator is 85% using the test media defined in the standard. It is to be noted that the performance of separators is highly dependent upon a number of factors, including:

- matching to preheaters,
- correct selection of equipment either side of the separator so as not to impede flow
- correct operation and maintenance practices

For such reasons, it may be appropriate to consider a safety factor in respect of the separation efficiency in considering the design of the system. It is also recommended that the separator including equipment such as the heaters that will be used be certified to a recognised standard.

Additionally, in consideration of the potential that such equipment has to result in a hazard to safety if not designed, operated and maintained appropriately, a requirement has been included for them to meet the safety requirements of a recognised standard.

It is to be noted that at the time of writing, CIMAC Working Group 7 are discussing the next steps in the development of CWA 15375 with an aim of publishing the next iteration as a formal European or ISO Standard.

3. Source / derivation of the proposed IACS Resolution

1. MAN 'Guidelines for Operation on Fuels with less than 0.1% Sulphur'
2. Wartsila 'Quality requirements and recommendations for heavy fuel oil'
3. 'Marine diesel engines, catalytic fines and a new standard to ensure safe operation - Separation Performance Standard'. Written by Alfa Laval, BP Marine and MAN B&W Diesel

4. CWA 15375 - Separators for marine residual fuel. Performance testing using specific test oil.
5. CIMAC – Recommendations concerning the design of heavy fuel treatment plants for diesel engines – Number 25/2006
6. ISO 12156-1: ‘High-frequency reciprocating rig test’
7. ISO 8217: ‘Specifications for marine fuels’
8. EN 12547, Centrifuges — Common safety requirements
9. IACS UI SC123 ‘Machinery Installations - Service Tank Arrangements’
10. IACS UI SC255 ‘Fuel pump arrangement required for ships to maintain normal operation of propulsion machinery when operating in emission control areas and non-restricted areas’
11. IACS UR Z26 Alternative certification scheme (ACS)
12. SOLAS Regulation II-I/26.3
13. ISO/IEC/IEEE 29148:2011, ‘Systems and software engineering — Life cycle processes — Requirements engineering’
14. CIMAC Guideline ‘Cold flow properties of marine fuel oils’

4. Summary of Changes intended for the revised Resolution

None

5. Points of discussions or possible discussions

One view was expressed in the PT that it may be too prescriptive to define specific values in terms of fuel characteristics as what is appropriate for one engine manufacturer may not be appropriate for another manufacturer.

In light of the variability in practices between members and that CWA 15375 does not have the formal status of a European Standard, it was debated as to whether a requirement for Type Approval specifically would be appropriate. It is possible that this point will be further discussed as there may be other national standards to which such equipment is otherwise certified. It is worth noting that a Japanese standard for manufacturers works tests exists - JIS F6601-1996 ‘Shipbuilding-Shop test code for centrifugal oil separators’.

A further discussion point may be the verification requirements for fuel oil pumps as it is understood that the requirements for witness tests and types of certification may differ between societies.

6. Attachments if any

None

Technical Background (TB) document for Rec 151 (Rev.1 Nov 2020)

1. Scope and objectives

In the Task which was raised by a Survey Panel Member, it was noted that the New Rec 151 'Recommendation for petroleum fuel treatment systems for marine diesel engines' contains numerous paragraphs relating to requirements, to approval of plans and to survey activities; thus Rec 151 is written in a way more appropriate for an IACS UR rather than an IACS Recommendation, such as approval of plans and requirements to survey activities.

Following discussions, it was concluded that the qualified majority of Survey Panel concurred with the view that according to the panel responsibility, this matter should be transmitted to Machinery Panel for their consideration.

2. Engineering background for technical basis and rationale

In the Rev.1 of Rec. No.151, changes have been made to reflect the 'non-mandatory' nature of the document.

Due to indicated risk during future in the future audits it has been agreed by Machinery and Survey Panel Chair to take suitable measures to eliminate the risk of potential problems.

3. Source/derivation of the proposed IACS Resolution

None

4. Summary of Changes intended for the revised Resolution:

The wording in the clauses indicated as 'requirements' in the Rec. 151(New) should be have been deleted or modified by using terms related to 'recommendation(s)'.

5. Points of discussions or possible discussions

Substantive modifications may be considered at a later stage for further improvement of this Rec based upon lessons learnt by individual Societies. One member also opined that some clauses in Rec. No.151 were requirements and not recommendations. It was decided to discuss this issue at that later stage, when Rev.2 of the Rec. is considered.

6. Attachments if any

None

Technical Background (TB) document for Rec 151 (Rev.2 Nov 2023)

1. Scope and objectives

According to the decision made by Machinery Panel, this Rec. has been updated as necessary to make it more consistent without ambiguity.

2. Engineering background for technical basis and rationale

Terms and definitions have been modified using technical language to be appropriate allowing technically unambiguous implementation of this Rec. by individual classification societies.

3. Source/derivation of the proposed IACS Resolution

None

4. Summary of Changes intended for the revised Resolution:

The word "must" which remained in Para. 3.2.7 and 7.3.3 was eliminated.

One member proposed to modify the scope of application and it has been clarified; and footnotes with reference relevant ISO 8217 and ISO ISO/PAS 23263:2019 have been added. Furthermore, references to those standards have been inserted in certain parts of this Recommendation.

One Member proposed modification of definitions in Section 2 and it has been implemented.

Members' proposals regarding functional and equipment level objectives were reviewed and modified to improve this Rec.'s clarity and alignment with definitions used in other IACS instruments.

Corrections have been made to certain oil fuel technical criteria (such as sulphur content, amount of catalyst fines) mentioned in this Rec., Part II dealing with Test methods.

One Member proposed to insert reference to ASTM D4740 – 20 method in Section 7.3 of this Rec. as guidance on compatibility test kits, approved or recommended by the fuel oil manufacturer testing. Finally, re-numbering has been done in the said Section according to the modifications introduced therein.

One Member proposed to insert reference to newly published standard EN 17763:2022 applicable for testing and certification of Marine fuel centrifuges *instead* of withdrawn previous standard CWA EN 15375:2005. The test acc. to the new standard is basically the same, but in case of new Certified Flow Rate (CFR) testing, the demands have been strengthened so that the results are more accurate, and centrifuges are individually tested instead of a test of two centrifuges of the same range and scale. The change has been discussed within the Panel and further consulted with the industry, and no objections on proposed change of referenced standard has been received.

5. Points of discussions or possible discussions

This Rec.151 may be adopted for other so called "alternative fuel" types possessing similar properties as oil fuels (e.g., biofuels or its blends) that may be subject of further IACS instruments development.

The draft revision of this Rec. was reviewed by CIMAC without comment, and comments made by Survey Panel have been reflected in revision 2 of this Rec.

6. Attachments if any

None

Recommendation No. 152

“Survival crafts launching stations. Guidance for applying the requirements of 11.3.1 of the IGC Code (on ships constructed on or after 1 July 2016)”

Summary:

This is a new document, initial recommendation, an outcome of discussion about water spray protection of the exposed survival crafts and muster stations introduced by 11.3.1.7 of revised IGC Code (Resolution MSC.370(93)).

The PT established by the IACS Safety Panel, while developing interpretation of this paragraph, found it inconsistent that while exposed survival crafts and muster stations require protection, the launching stations and routes do not.

The initial proposal for the recommendation was prepared by PT and suggest to consider launching station and routes to be also protected by the water spray. Current official version of the UI is a product of PT proposal and following discussion in IACS Safety Panel.

Part A. Revision History

Version no.	Approval date	Implementation date when applicable
New (Apr 2018)	30 April 2018	-

- **New (Apr 2018)**

.1 Origin of Change:

- Suggestion by IACS Member

.2 Main Reason for Change:

The Recommendation is aimed to draw attention to practical considerations following requirement for fire protection of exposed to cargo area liferafts from aspect of availability of their launching routes in case of fire in cargo area and to protection of their embarkation stations.

.3 List of non-IACS Member Classification Societies contributing through the TC Forum and/or participating in IACS Working Group:

None

.4 History of Decisions Made:

The proposal to develop recommendation was made during development of related to the topic unified interpretation of §11.3.1 of the IGC Code as amended by Resolution MSC.370(93) requiring spray protection of stowed liferafts locations when they face cargo area.

The recommendation was proposed along with developed draft Unified Interpretation of IGC Code paragraphs according to tasks list (SP15020 task 4) assigned to IACS Safety Panel.

This REC is product of Safety Panel preliminary work (proposal, prepared by PT) and rounds of discussions in the panel to finalise the proposed recommendation.

.5 Other Resolutions Changes

None

.6 Dates:

Original Proposal: 28 May 2017 by an IACS Member

Panel Approval: 19 December 2017 (Ref: PS15020 Task 4)

GPG Approval: 30 April 2018 (Ref: 16238_IGh)

Part B. Technical Background

List of Technical Background (TB) documents for Rec 152:

Annex 1. **TB for New (Apr 2018)**

See separate TB document in Annex 1



Technical Background (TB) document for Rec 152 (New Apr 2018)

1. Scope and objectives

The Rec is suggesting to consider practical aspects of life rafts launching and embarkation it is further development of new requirement of 11.3.1 proposed by amended IGC Code (Resolution MSC.370(93)).

2. Engineering background for technical basis and rationale

SOLAS III/B/1/ Regulation 13.6 requires that liferafts for throw-overboard launching shall be so stowed as to be readily transferable for launching on either side of the ship. The rule is applicable to both, life rafts stowed on accommodation decks and remote life raft. For remote life rafts transfer to ship side can be complicated or impossible due to heat radiation in case of fire in cargo area.

Launching routes for life rafts located at accommodation will, in most cases, be protected by accommodation structure (are not exposed to cargo area) and does not require water spray protection. However, some smaller vessels may have liferafts stowed closer to the accommodation front and shortest transfer route (forward of the accommodation) will become exposed. Similar situation will occur for gas carriers who have accommodation forward of cargo area and will have transfer route exposed to cargo area. For such cases life rafts launching routes may either require protection or not require the same. I.e. the protection will be required depending on the life raft arrangement onboard

3. Source/derivation of the proposed IACS Resolution

N/A.

4. Summary of Changes intended for the revised Resolution:

N/A.

5. Points of discussions or possible discussions

Comments from IACS Members	PT's Reply
<p>(1) As was mentioned by one Safety Panel Member, SOLAS does not have a requirement on the capacity of the remote liferaft (III/31.1.4). Normally small liferafts of six persons capacity are used, since the LSA Code states in 4.1.2.1 that "no liferaft shall be approved which has a carrying capacity of less than six persons...". Therefore, the Safety panel Member suggested to delete "of required capacity" (moreover, MSC.1.Circ./1490/Rev.1 and UI SC213 require two lifejackets only).</p>	<p>(1) In principle, PT has no objection to incorporate this comment to avoid confusion.</p>

<p>(2) Another Safety Panel Member mentioned that the current proposed wording sounds vague; "Depending on the life rafts arrangement" should be deleted from the start of the recommendation. As this is a recommendation it is suggested that "shall" should be replaced by "should". The proposed amendments together with other editorial improvements would result in the recommendation reading as follows: "Water spray protection should be considered for exposed launching routes from the life rafts stowage location to the ship's side unless life rafts of the required capacity are located and ready for launching at both sides." Alternatively, situations where a water spray protection is (or is not) required should be provided, perhaps with diagrams to illustrate.</p> <p>(3) One Safety Panel Member disagreed with a specific interpretation in the draft UI for WATER-SPRAY SYSTEM, neither the draft Recommendation for the remote life rafts launching stations on the following grounds: According to the draft UI and the Recommendation, the remotely located survival craft (ref. SOLAS III/Reg.31.1.4) shall be protected / or the exposed launching routes from the life rafts stowage location to the ship side are recommended to be protected by the water-spray system required by 11.3.1 of the IGC Code. Though there is no specific wording or background was provided in the Code, the Panel Member was of the view that the application of the WATER-SPRAY SYSTEM requirement in 11.3.1 of the IGC Code would be desirable for only the survival crafts which located close to accommodation spaces and service spaces and can accommodate the total number of persons on board. It was also mentioned that some SOLAS regulations not apply to the remotely located survival crafts which can't not accommodate the total number of persons on board, such as SOALS III/Reg.6.2.2 (radar transponder),</p>	<p>(2) PT has no objection to incorporate this comment.</p> <p>(3) The PT considers that 11.3.1-7. is to be applicable also to remote life raft facing cargo area because this IGC Code requirement is clearly applicable to "exposed" liferafts irrespective of SOLAS requirements or location of the craft, the only condition is "exposed". Besides, the remote life raft may be considered "an escape" route for trapped forward crew in case of incident (fire or toxic cargo escape on deck).</p>
---	---

<p>Reg.13.1.5 and Reg.13.4.4.</p> <p>Also, the design and installation of awfully long piping for the WATER-SPRAY SYSTEM to protect the remotely located survival crafts would be very difficult, and the maintenance of such piping would be problematic for ship owners.</p> <p>By the above reasons, the Panel Member suggested to drop the specific draft UI relating to the remotely located survival crafts protection by the WATER-SPRAY SYSTEM and the draft Rec. on guidance for applying the requirements of 11.3.1 of the IGC Code for remote life rafts launching stations.</p>	
---	--

6. Attachments if any

N/A.

Recommendation No. 153

“Recommended procedures for software maintenance of computer based systems on board”

Summary:

The IACS recommendation suggests minimum requirements as well as procedures for maintenance and update of software on board ships.

Part A. Revision History

Version no.	Approval date	Implementation date when applicable
New (Sep 2018)	21 September 2018	-

- **New (Sep 2018)**

.1 Origin of Change:

- Other (*developed according to roadmap of IACS Cyber Systems Panel*)

.2 Main Reason for Change:

N/A

.3 List of non-IACS Member Classification Societies contributing through the TC Forum and/or participating in IACS Working Group:

N/A

.4 History of Decisions Made:

- Form A was approved by GPG with 17052_IGc dated 11 May 2017.
- Development of first draft made by the Small Team, conducted via correspondence and face-to-face meetings. The team members are: CCS (lead), LR, NK, RINA
- Revised and agreed by the Cyber Systems Panel during the Fifth Cyber Systems Panel meeting (London, 12-15 March 2018).
- Submitted to GPG for appropriate actions on 24 March 2018.
- Comments received from GPG on 20 April 2018 and accounted for, as applicable in the current revision
- Forwarded to JWG/CS for review on 24 May 2018.
- Resubmitted to GPG for approval on 9 August 2018.

.5 Other Resolutions Changes

N/A

.6 Dates:

Original Proposal: 27 October 2016

Made by Cyber System Panel

Panel Approval: 15 March 2018 (Ref: PC17001)

GPG Approval: 21 September 2018 (Ref: 17052_IGn)

Part B. Technical Background

List of Technical Background (TB) documents for Rec 153:

Annex 1. **TB for New (Sep 2018)**

See separate TB document in Annex 1



Technical Background (TB) document for Rec 153 (New Sep 2018)

1. Scope and objectives

The Procedure for Software Updates are relevant to all computer systems including radio and navigation equipment installed on board ship.

The objective of the task was to develop an IACS recommendation on minimum requirements as well as procedure for maintenance and update of software on board ship.

2. Engineering background for technical basis and rationale

During the first panel meeting, the panel identified twelve subject matters that the panel should focus on during the following twelve months. These twelve subject matters were prioritized and were used as the basis of the roadmap developed in response to GPG request (GPG81, FUA no.14), sent on 21 October 2016 (GPG 16188, PC16007).

After further correspondence and revisions to the roadmap it received its final approval from GPG in their email sent on 16 January 2017 (GPG 16036bIGy).

This task on Procedure for Software Updates covers the first subject:

Based on a review of: existing industry standards, the associated BIMCO, common practice of owners, etc. outline a set of minimum requirements suited to the maritime industry which may form the basis of general guidance and consider the merit of developing different levels of criteria that could be used later to associate the burden with the overall risks involved.

During the task, minimum requirements as well as procedure for maintenance and update of software on-board the ship will be established by reviewing of existing industry standards.

3. Source/derivation of the proposed IACS Resolution

The third subject on the roadmap which finally approved from GPG in their email sent on 16 January 2017 (GPG 16036bIGy).

4. Summary of Changes intended for the revised Resolution:

N/A

5. Points of discussions or possible discussions

According the Form A, the title of this recommendation is Procedure for Software Updates. After discussion on small team, the title was changed to Recommended procedures for software maintenance of shipboard equipment and systems and approved by the panel.

With regarding to the scope of this recommendation, one member suggested that it is only applicable to class related computer based systems (defined by E22). In

fact, IMO also pays close attention to software maintenance for mandatory shipborne navigational equipment. For the nature of this recommendation, it is applicable to any computer based systems.

With regarding to remote updates, the first draft of this recommendations cover requirements of remote updates. Considering the separate recommendations for remote access/updates has been finished (PC17011), after discussion by panel, relevant requirement was deleted, detailed requirements was referred to Recommendation number PC11.

6. Attachments if any

None

Recommendation No. 154

“Recommendation concerning manual/local control capabilities for software dependent machinery systems”

Summary:

The IACS recommendation titled “Manual Local Control” propose how requirements in SOLAS concerning local control of machinery can be applied on machinery installations depending on computer based systems.

Part A. Revision History

Version no.	Approval date	Implementation date when applicable
New (Sep 2018)	21 September 2018	-

- **New (Sep 2018)**

.1 Origin of Change:

- Other (*developed according to roadmap of IACS Cyber Systems Panel*)

.2 Main Reason for Change:

N/A

.3 List of non-IACS Member Classification Societies contributing through the TC Forum and/or participating in IACS Working Group:

N/A

.4 History of Decisions Made:

- Form A was approved by GPG under 16046_IGe dated 11 May 2017.
- Development of first draft made by the Small Team, conducted via correspondence, telephone discussions and face-to-face meetings. The team members are: DNV GL (lead), BV, ABS, IRS
- Revised by the Cyber Systems Panel during the Fifth Cyber Systems Panel meeting (London, 12-15 March 2018).
- Submitted to GPG for appropriate actions on 16 May 2018.
- Forwarded to JWG/CS for review on 24 May 2018.
- Resubmitted to GPG for approval on 16 July 2018.

.5 Other Resolutions Changes

N/A

.6 Dates:

Original Proposal: 27 October 2016

Made by Cyber System Panel

Panel Approval: 15 March 2018 (Ref: PC17002)

GPG Approval: 21 September 2018 (Ref: 16046_IGs)

Part B. Technical Background

List of Technical Background (TB) documents for Rec 154:

Annex 1. **TB for New (Sep 2018)**

See separate TB document in Annex 1



Technical Background (TB) document for Rec 154 (New Sep 2018)

1. Scope and objectives

Today's machinery installations normally depend on programmable control systems, often integrated in common control system networks.

The intention of the recommendation is to ensure a consistent practice for machinery systems that depend on programmable control systems in line with the SOLAS regulations.

This recommendation applies to new ships and may be applied to ships in service.

2. Engineering background for technical basis and rationale

During the first panel meeting, the panel identified twelve subject matters that the panel should focus on during the following twelve months. These twelve subject matters were prioritized and were used as the basis of the roadmap developed in response to GPG request (GPG81, FUA no.14), sent on 21 October 2016 (GPG 16188, PC16007).

After further correspondence and revisions to the roadmap it received its final approval from GPG in their email sent on 16 January 2017 (GPG 16036bIGy).

This task on Manual Local Control covers the second subject. It should be noted that the name of this task originally was "Manual / local backup capabilities", but it was changed during the process as the title may be understood to concern (what / how to) backup data.

Complex machinery installations normally depend on programmable control systems, often integrated in common control system networks. The control system may consist of a combination of embedded units physically integrated in the machinery components and/or control units located in the vicinity of the machinery or in another location on board.

This means that

- *local control may not be possible without fully functional programmable control system units**
- *automatic control functions may reside in local control system units*

and furthermore

- *local control may depend on control system units located remotely*

(* - examples of this may be common rail engines, electrical drives, gas fuelled engines)

The SOLAS regulations that are particularly relevant in this connection are the following:

SOLAS II-1/Reg. 31.2 (Machinery controls)

2 *Where remote control of propulsion machinery from the navigating bridge is provided, the following shall apply:*

...

.6 *it shall be possible to control the propulsion machinery locally, even in the case of failure in any part of the remote control system. It shall also be possible to control the auxiliary machinery, essential for the propulsion and safety of the ship, at or near the machinery concerned*

...

SOLAS II-1/Reg. 49 (Unattended machinery spaces)

4 *It shall be possible for all machinery essential for the safe operation of the ship to be controlled from a local position, even in the case of failure in any part of the automatic or remote control systems.*

The intention of the SOLAS regulations is to provide a robust fall-back option for controlling essential machinery and its auxiliaries in case of any failures affecting the remote control system. It shall be possible to man the local control position at or near the machinery served, then disconnect any remote control systems with its possible failures, and operate the machinery locally. Furthermore, necessary local indicators shall provide readings for the most critical parameters.

Complex integrated systems are increasingly vulnerable for cyber security threats, and malicious code may also affect local controllers and hence the ability to operate machinery locally. This was obviously not part of the intention when the SOLAS regulations were written, but is an emerging threat that substantiates the initial SOLAS regulations.

The referred SOLAS principles of local control are considered to be an essential aspect of the vessel safety – the ability to maintain manoeuvrability after system failures.

3. Source/derivation of the proposed IACS Resolution

The second subject on the roadmap which finally approved from GPG in their email sent on 16 January 2017 (GPG 16036bIGy).

4. Summary of Changes intended for the revised Resolution:

N/A

5. Points of discussions or possible discussions

1. The title of this task was originally "Manual / local backup capabilities". When the Recommendation eventually was circulated to the panel members, one member commented that the document title indicated that the Recommendation concerned (how to) back-up data. To avoid this, the title was changed to "Manual Local Control".
2. One members commented that the document had no requirements, nor recommendations on how to check the proper state of cyber systems in case of

failure of part of the control chain (remote or local), and proposed the following to be included in the Recommendation:

"Local and Remote Crew shall have a way to verify integrity of cyber systems including ICS, PLC, Network Facilities and / or standard operating system based computers relevant to SOLAS II-1/reg. 31-2 definition."

The proposal was communicated to the members during the 5th meeting. It was discussed if such requirement also should apply to other systems/components, and not be limited to those relevant for the subject Recommendation.

The good intention of the proposal is indisputable, but the majority of the members did not support to include this into the subject Recommendation. It was discussed to instead consider this during future revision of UR E22.

3. Cyber security aspects have not been incorporated in the first release of the Recommendation, awaiting a common approach to address this in future revision of the appropriate recommendation(s).

6. Attachments if any

None

Recommendation No. 155

“Contingency plan for onboard computer based systems”

Summary:

This recommendation concerns the need for policies and procedures to be applied in case of the failure or malfunction of onboard computer based systems which could lead to dangerous situations with respect to human safety, safety of the vessel and/or threat to the environment.

Part A. Revision History

Version no.	Approval date	Implementation date when applicable
New (Sep 2018)	21 September 2018	-

- **New (Sep 2018)**

.1 Origin of Change:

- Other (*Cyber Systems Panel Task no. PC17003*)

.2 Main Reason for Change:

N/A

.3 List of non-IACS Member Classification Societies contributing through the TC Forum and/or participating in IACS Working Group:

N/A

.4 History of Decisions Made:

- Ref. to Form A of Cyber Systems Panel Task no. PC17003.
- Development of first draft made by the Small Team, conducted via correspondence and face-to-face meetings. The team members are: KR (lead), CRS, PRS and RS
- Revised and agreed by the Cyber Systems Panel through correspondence.
- Submitted to GPG for appropriate actions on 24 March 2018
- Comments received from GPG on 20 April 2018 and accounted for, as applicable in the current revision
- Forwarded to JWG/CS for review on 24 May 2018.
- Resubmitted to GPG for approval on 16 July 2018.

.5 Other Resolutions Changes

N/A

.6 Dates:

Original Proposal: 16 January 2017

Made by GPG (16036bIGy)

Panel Approval: 14 May 2018 (Ref: PC17003)

GPG Approval: 21 September 2018 (Ref: 17059_IGI)

Part B. Technical Background

List of Technical Background (TB) documents for Rec 155:

Annex 1. **TB for New (Sep 2018)**

See separate TB document in Annex 1



Technical Background (TB) document for Rec 155 (New Sep 2018)

1. Scope and objectives

The applicable scope for contingency plan were limited to post failure condition of critical essential computer based system, failure of which could immediately lead to dangerous situations for human safety, safety of the vessel and/or threat to the environment, especially belonging to system category III in accordance with UR E22.

The aspects of contingency related to topics such as engineered backups, redundancy, reinstatement etc., are dealt with in the other relevant recommendations.

The objective of the task was to develop an IACS recommendation on contingency plan in a 'Post Failure' situation for essential computer based systems.

2. Engineering background for technical basis and rationale

During the first panel meeting, the panel identified twelve subject matters that the panel should focus on during the following twelve months. These twelve subject matters were prioritized and were used as the basis of the roadmap developed in response to GPG request (GPG81, FUA no.14), sent on 21 October 2016 (GPG 16188, PC16007).

After further correspondence and revisions to the roadmap it received its final approval from GPG in their email sent on 16 January 2017 (GPG 16036bIGy).

This task on Contingency Post Failure covers the third subject:

- Increasing levels of automation based on computer technology is inevitably accompanied by reduced practice and familiarity.
- The consequence is that when manual intervention is required the crew/operators are less effective at responding than they were before the computer based systems were introduced.
- The general good reliability of computer based systems compounds the problem of poor emergency responses due to the limited number of opportunities to practice responses.
- As the functioning of computer based systems is not visible in the way that mechanical control systems once were, opportunities for crew/operators to accumulate useful system experience, that will be of assistance during electronic control system failures, is not developed.

Therefore, it is necessary to consider the actions that would need to be taken by the crew in a 'Post Cyber Systems Failure' situation. This should be planned during design and development phases of vessel construction. Furthermore, guidelines should be readily available for the crew to give adequate guidance under failure conditions of critical essential computer based systems, especially belonging to system category III in accordance with UR E22 (Rev.2). In this context, 'contingency plan' is a procedure developed to help the crew to respond effectively to a critical

failure condition in a computer based system with account taken of the time available to respond.

3. Source / derivation of the proposed IACS Resolution

The third subject on the roadmap which finally approved from GPG in their email sent on 16 January 2017 (GPG 16036bIGy).

4. Summary of Changes intended for the revised Resolution

N/A

5. Points of discussions or possible discussion

The application scope of contingency plan was agreed to apply to system category III during the meeting since the system immediately lead to ship's dangerous situation, and quick and effective response to post failure condition is crucial to ensure ship's safety.

It was controversial issue who has main responsibility for developing contingency plan between system integrator and ship owner, and it was generally agreed that the view that Ship Owner has overall responsibility for developing contingency plan based on response plan which should be developed by System Integrator in cooperation with Suppliers.

6. Attachments if any

None

Recommendation No. 156 "Network Architecture"

Summary:

The objective of the recommendation is to develop broad guidelines on shipboard network architecture. The recommendation broadly covers various aspects from design to installation phases which should be addressed by the system integrator and yard.

Part A. Revision History

Version no.	Approval date	Implementation date when applicable
New (Sep 2018)	21 September 2018	-

- **New (Sep 2018)**

.1 Origin of Change:

Other (*Cyber Systems Panel Task no. PC17004*)

.2 Main Reason for Change:

N/A

.3 List of non-IACS Member Classification Societies contributing through the TC Forum and/or participating in IACS Working Group:

N/A

.4 History of Decisions Made:

- Ref. to Form A of Cyber Systems Panel Task no. PC17004.
- Development of first draft made by the Small Team, conducted via correspondence and face-to-face meetings. The team members are: IRS (lead), ABS, CCS, PRS
- Revised and agreed by the Cyber Systems Panel through correspondence.
- Submitted to GPG for appropriate actions on March 2nd 2018
- Comments received from GPG on April, 2018 and accounted for, as applicable in the revised draft
- Forwarded to JWG/CS for review on 24 May 2018.
- Resubmitted to GPG for approval on 16 July 2018.

.5 Other Resolutions Changes

N/A

.6 Dates:

Original Proposal: 16 January 2017

Made by GPG (16036bIGy)

Submitted to GPG after panel approval: 2 March 2018 (Ref: PC17004)

GPG Approval: 21 September 2018 (Ref: 17113_IGr)

Part B. Technical Background

List of Technical Background (TB) documents for Rec 156:

Annex 1. **TB for New (Sep 2018)**

See separate TB document in Annex 1



Technical Background (TB) document for Rec 156 (New Sep 2018)

1. Scope and objectives

1 Introduction

With increased usage of Cyber systems, the role of a network has grown beyond conventional IT systems to include OT systems. Initially used for interconnecting more than one system to form a LAN, even standalone systems use Networks to connect their smart sensors with main processor.

Ensuring that a Network is designed, tested and operated to meet its intended operational and safety requirements, is essential, for a safe and efficient operation of vessel.

This task on Network Architecture aims to establish framework for the specification of a network's components, their functional organization, configuration, operational principles, procedures and data formats

During the task, minimum requirements will be addressed towards Network Architecture for Shipboard networked systems, through review of existing industry standards,

2 Scope & Objective

The objectives for this recommendation is:

- To develop recommendations on design philosophy for network redundancy, network segregation when used for essential services.
- To identify data requirements for network systems
- To develop recommendations for network monitoring and alarm
- To identify minimum cyber safe practices for on board networks
- To develop recommendation for on board installation and testing of network
- To identify acceptable standards for Network equipment including network cable.

Whereas the scope of this recommendation should be limited to network architecture of class-related items, connections to other cyber systems may be considered, when such connections may affect the of operation of class-related cyber systems.

For devices which are connected to computer based systems through analog transmission networks the monitoring, installation and safety requirements shall be as per existing Classification rules as applicable to a particular system. The scope includes ship IT and OT networks.

The recommendation also identifies documentation to be provided and retained which can be used as reference for intent of network design.

2. Engineering background for technical basis and rationale

During the first panel meeting, the panel identified twelve subject matters that the panel should focus on and use as the basis of the roadmap developed in response to GPG request (GPG81, FUA no.14), sent on 21 October 2016 (GPG 16188, PC16007).

This recommendation on Network Security covers the seventh subject.

Ship board control networks have evolved from simple stand-alone systems to integrated systems over the years and the demands for having a connectivity remote from the vessel for either for maintenance, remote or monitoring is in increasing

Incorporation of Ethernet technology has resulted in a growing similarity between the once disconnected fieldbus and Internet technologies. This has given rise to new terms such as industrial control networking, which encompasses not only the functions and requirements of conventional fieldbus, but also the additional functions and requirements that Ethernet-based systems present.

The network design forms the basis for reliable and robust network. Issues such as compatibility of various devices, communication between devices, communication from various systems and sub systems, need due consideration during design phase.

The network designer should have an overall holistic view of the ship network system. The network should be capable of carrying the required data in a specified time to meet the application demand. The later aspect requires detailed study of various protocols through which the system data flows.

It is observed that even when such in-depth study is carried out during design phase, there are rarely documented and reviewed by classification societies. As a result, when subsequent modifications are carried out on ship systems network to meet new demands or change in technology, the original intent /design criterion is rarely considered during modifications.

Network resilience can be improved through the partition of components and thereby a reduction in the attack surface. This would limit the infection propagation and reduce the potential damage to or availability of the ship's systems.

Monitoring and alarms of critical network parameters is essential to ensure a robust system. The present recommendations also identify important tests to be carried out after installation.

The recommendations are applicable to vessel's network systems using digital communication to interconnect systems within the ship or from the ship to equipment or networks off the ship. The interconnection may be intended only for monitoring (read only) or for control or for the creation of new functionality with integrated systems.

3. Source/derivation of the proposed IACS Resolution

The following international or industrial standards have been considered as a technical background for this recommendation.

1. IMO MSC-FAL.1/Circ.3, "Guidelines on Maritime Cyber Risk Management", July 2017
2. ISO/IEC 27001:2013, "Information technology – Security techniques – Information security management systems – Requirements", 2013
3. NIST "Framework for Improving Critical Infrastructure Cybersecurity", version 1.1, 2017
4. *ISO 16425 "ships and marine technology Guidelines for the installation of ship communication networks for shipboard equipment and systems"*
5. *IACS UR E22 "On Board Use and Application of Computer Based Systems", June 2016*
6. IEC 62443-2-1 Establishing an industrial automation and control system security program

4. Summary of Changes intended for the revised Resolution:

N/A

5. Points of discussions or possible discussions

N/A

6. Attachments if any

None

Recommendation No. 157 "Data Assurance"

Summary:

The IACS recommendation suggests minimum requirements as well as procedures for Data Assurance on board ships.

Part A. Revision History

Version no.	Approval date	Implementation date when applicable
New (Sep 2018)	21 September 2018	-

- **New (Sep 2018)**

.1 Origin of Change:

- Other (*developed according to roadmap of IACS cyber system panel*)

.2 Main Reason for Change:

N/A

.3 List of non-IACS Member Classification Societies contributing through the TC Forum and/or participating in IACS Working Group:

N/A

.4 History of Decisions Made:

- Form A noted by GPG under 17158_IAa dated 27 October 2017.
- Development of first draft made by the Small Team, conducted via correspondence and face-to-face meetings. The team members are: LR (lead), CRS, DNV GL, RINA
- Revised and agreed by the Cyber Systems Panel during the Fifth Cyber Systems Panel meeting (London, 12-15 March 2018).
- Submitted to GPG for appropriate actions on 22 March 2018.
- Comments received from GPG on 20 April 2018 and accounted for, as applicable in the current revision
- Forwarded to JWG/CS for review on 31 May 2018.
- Resubmitted to GPG for approval on 9 August 2018.

.5 Other Resolutions Changes

N/A

.6 Dates:

Original Proposal: 27 October 2016 Made by Cyber Systems Panel
Panel Approval: 15 March 2018 (Ref: PC17005)
GPG Approval: 21 September 2018 (Ref: 17158_IGi)

Part B. Technical Background

List of Technical Background (TB) documents for Rec 157:

Annex 1. **TB for New (Sep 2018)**

See separate TB document in Annex 1



Technical Background (TB) document for Rec 157 (New Sep 2018)

1. Scope and objectives

The Data Assurance recommendation is relevant to all OT related computer systems on board ship.

The objective of the task was to develop an IACS recommendation on minimum requirements for data assurance on board ship.

This recommendation applies to new ships and may be applied to ships in service.

2. Engineering background for technical basis and rationale

During the first panel meeting, the panel identified twelve subject matters that the panel should focus on during the following twelve months. These twelve subject matters were prioritized and were used as the basis of the roadmap developed in response to GPG request (GPG81, FUA no.14), sent on 21 October 2016 (GPG 16188, PC16007).

After further correspondence and revisions to the roadmap it received its final approval from GPG in their email sent on 16 January 2017 (GPG 16036bIGy).

This task on Data Assurance covers the fifth subject:

Regulation strongly focuses on system's hardware and software development, however data related aspects are covered comparatively poorly. Data available on ships has become very complex and in a large volume, meaning a user is unlikely to spot an error and it would be unreasonable to expect them to do so. Cyber systems depend not only on hardware and software, but also on the data they generate, process, store and transmit. These systems are becoming more data intensive and data centric, often used as decision support and advisory systems and for remote digital communication.

During the task, minimum requirements were established by reviewing of existing industry standards:

1. NIST Special Publication 800-53 (Rev. 4)
2. IMO MSC 96/4/1 "The Guidelines on Cyber Security On board Ships", version 2.0, BIMCO, CLIA, ICS, INTERCARGO, INTERTANKO, OCIMF and IUMI, 2017
3. FIPS PUB 199
4. NIST "Framework for Improving Critical Infrastructure Cybersecurity", version 1.0
5. Data Safety Guidance by The data safety initiative working group (DSIWG)
6. ISO 8000-8:2015, "Data quality — Part 8: Information and data quality: Concepts and measuring"
7. IACS UR E22 "On Board Use and Application of Computer Based Systems", June 2016

3. Source/derivation of the proposed IACS Resolution

The fifth subject on the roadmap which finally approved from GPG in their email sent on 16 January 2017 (GPG 16036bIGy).

4. Summary of Changes intended for the revised Resolution:

N/A

5. Points of discussions or possible discussions

Interface for Data Assurance for Ship board systems, ship to ship or ship to shore communication

6. Attachments if any

None

Recommendation No. 158

“Physical Security of onboard computer based system”

Summary:

This recommendation suggests the recommended measures for the onboard computer based systems to prevent unauthorized physical access, misuse of removable devices and theft of the systems.

Part A. Revision History

Version no.	Approval date	Implementation date when applicable
New (Oct 2018)	25 October 2018	-

- **New (Oct 2018)**

.1 Origin of Change:

- Other (*Cyber Systems Panel Task no. PC17006*)

.2 Main Reason for Change:

N/A

.3 List of non-IACS Member Classification Societies contributing through the TC Forum and/or participating in IACS Working Group:

N/A

.4 History of Decisions Made:

- Ref. to Form A of Cyber Systems Panel Task no. PC17006.
- Development of first draft made by the Small Team, conducted via correspondence and face-to-face meetings. The team members are: NK (lead), BV, KR and RS
- Revised and agreed by the Cyber Systems Panel through correspondence on 25 June 2018.
- Submitted to GPG for appropriate actions on 25 June 2018
- Comments received from GPG on 23 July 2018 and accounted for, as applicable in the current revision

.5 Other Resolutions Changes

N/A

.6 Dates:

Original Proposal: 16 January 2017

Made by GPG (16036bIGy)

Panel Approval: 25 June 2018 (Ref: PC17006)

GPG Approval: 25 October 2018 (Ref: 17114_IGh)

Part B. Technical Background

List of Technical Background (TB) documents for Rec 158:

Annex 1. **TB for New (Oct 2018)**

See separate TB document in Annex 1



Technical Background (TB) document for Rec 158 (New Oct 2018)

1. Scope and objectives

The Physical Security recommendation is relevant to all computer based systems on board ships.

The objective of the task was to develop an IACS recommendation on physical security on computer based systems.

This recommendation applies to new ships and may be applied to ships in services.

2. Engineering background for technical basis and rationale

During the first panel meeting, the panel identified twelve subject matters that the panel should focus on during the following twelve months. These twelve subject matters were prioritized and were used as the basis of the roadmap developed in response to GPG request (GPG81, FUA no.14), sent on 21 October 2016 (GPG 16188, PC16007). This Recommendation on Physical Security covers the sixth subject.

As cyber technology is developing, computer based systems are widely implemented to shipboard equipment, and become essential to safe operations. There are cases that computer based systems, including critical control systems, are combined into integrated systems to provide effective and easy-to-use operations. They may be placed at easily accessible location. It may cause that unauthorized person could access such a system.

Unauthorized use of removable devices such as USB device may introduce malware, affect various computer based systems or corrupt such system program. Removable devices can be used for transferring data in various purposes including download files from Internet, storing business data and software maintenance for computer based system.

As computer system may be composed of detachable components, some components are potentially stolen or broken. Cables for data communicating and power supply are also at risk of disconnection or sniffing.

It is necessary to consider recommendations for physical security regarding physical access control, use of removable devices, and also recommendations for prevention of theft, damage or interruption of computer systems.

Remote control devices connected to computer systems shall be considered the same way regarding physical security.

3. Source/derivation of the proposed IACS Resolution

The following international or industrial standards have been considered as a technical background for this recommendation:

1. IMO MSC-FAL.1/Circ.3, "Guidelines on Maritime Cyber Risk Management", July 2017
2. NIST Special Publication 800-53 (Rev.4), April 2013
3. ISO/IEC 27002:2013, "Information technology – Security techniques – Code of practice for information security controls", October 2013
4. IEC 62443 - Industrial communication networks – Network and system security – Part 3-3: System security requirements and security levels, August 2013
5. The Guidelines on Cyber Security onboard Ships (Version 2.0: BIMCO, CLIA, ICS, INTERCARGO, INTERTANKO, OCIMF and IUMI)

4. Summary of Changes intended for the revised Resolution

None

5. Points of discussions or possible discussion

There is some overlaps with the other Recommendation regarding network segregation. After the development of 12 Recommendations, it may be necessary to discuss the amendment to remove overlaps.

6. Attachments if any

None

Recommendation No. 159

“Network security of onboard computer based systems”

Summary:

The Recommendation intends to:

- a) Provide a minimum set of recommended measures for the resilience of networks and networked systems onboard against cyber-related risks, vulnerabilities and threats, including awareness of operators about cybersecurity threats and procedures to prevent and react to cyber incidents.
- b) Provide appropriate levels of implementation of such measures, according to a risk-based approach where the type of ship, its operation, navigation, cargo, etc., as well as the extent to which IT and OT networks are used on board, their complexity and the type of onboard systems they apply to are taken into account.

Part A. Revision History

Version no.	Approval date	Implementation date when applicable
New (Sep 2018)	21 September 2018	-

- **New (Sep 2018)**

.1 Origin of Change:

- Other (*Cyber Systems Panel Task no. PC17007*)

.2 Main Reason for Change:

N/A

.3 List of non-IACS Member Classification Societies contributing through the TC Forum and/or participating in IACS Working Group:

N/A

.4 History of Decisions Made:

- Ref. to Form A of Cyber Systems Panel Task no. PC17007.
- Development of first draft made by the Small Team, conducted via correspondence and face-to-face meetings. The team members are: RINA (lead), CCS, DNV GL, KR.
- Revised and agreed by the Cyber Systems Panel during the Fifth Cyber Systems Panel meeting (London, 12-15 March 2018).
- Submitted to GPG for appropriate actions on 23 March 2018.

- Comments received from GPG on 20 April 2018 and accounted for in the current revision.
- Forwarded to JWG/CS for review on 24 May 2018.
- Resubmitted to GPG for approval on 16 July 2018.

.5 Other Resolutions Changes

N/A

.6 Dates:

Original Proposal: 16 January 2017 Made by GPG (16036bIGy)

Panel Approval: 15 March 2018 (Ref: PC17007) GPG

Approval: 21 September 2018 (Ref: 18041_IGj)

Part B. Technical Background

List of Technical Background (TB) documents for Rec 159:

Annex 1. **TB for New (Sep 2018)**

See separate TB document in Annex 1



Technical Background (TB) document for Rec 159 (New Sep 2018)

1. Scope and objectives

The objectives of this recommendation are:

- To provide a minimum set of recommended measures for the resilience of networks and networked systems on-board against cyber-related risks, vulnerabilities and threats.
- To provide a minimum set of recommended measures for the awareness of operators having access to networks and networked systems on-board about cyber-security threats and procedures to prevent and react to cyber-attacks.
- To provide appropriate levels of implementation of such measures, according to a risk-based approach where the type of ship, its operation, navigation, cargo, etc. are taken into account. The extent to which IT and OT systems are used on-board, their complexity, the type of on-board systems they apply to, in terms of criticality for the safety and security of shipping and for the protection of the marine environment, shall be taken into account as well.

Whereas the scope of this recommendation should be limited to network security of class-related items, connections to other cyber systems is taken into account, as long as such connections may affect the security of operation of class-related cyber systems.

This recommendation applies to new ships and may be applied to ships in service.

2. Engineering background for technical basis and rationale

During the first panel meeting, the panel identified twelve subject matters that the panel should focus on and use as the basis of the roadmap developed in response to GPG request (GPG81, FUA no.14), sent on 21 October 2016 (GPG 16188, PC16007).

This recommendation on Network Security covers the seventh subject.

The interconnections among the various network-based Information Technology (IT) and Operational Technology (OT) systems on-board modern ships, as well as the possibility to access them remotely, offer an extensive attack surface to malicious and/or incautious operators and amplify the risk of intentional or unintentional abuse.

It is essential to provide technological and organizational measures to ensure satisfactory resilience against possible cyber-attacks to networked systems, as well as to ensure the capability to react effectively and timely.

Technological and organizational measures may apply to all phases of the ship's lifecycle, from design to construction and operation. Several stakeholders may be involved, including owners, manufacturers, integrators and class societies.

The SANS Institute (<https://www.sans.org>) gives the following definition of Network Security:

Network Security is the process of taking physical and software preventative measures to protect the underlying networking infrastructure from unauthorized access, misuse, malfunction, modification, destruction, or improper disclosure, thereby creating a secure platform for computers, users and programs to perform their permitted critical functions within a secure environment.

<https://www.sans.org/network-security/>

When speaking of networks, events and circumstances to protect against are mainly “unauthorized access, misuse, malfunction, modification, destruction, or improper disclosure”:

- Unauthorized Access (to network resources)
- Misuse (of data, of network resources)
- Malfunction (of network resources – also due to bugs or hardware failures)
- [Unauthorized] Modification (of data, connections, nodes, services, protocols, ...)
- [Unauthorized] Destruction (of data, connections, nodes, services, ...)
- Improper Disclosure (of information)

Specific Cyber Risk Management for protecting network infrastructure is then fundamental to safe and secure shipping operation.

To the purpose of providing a robust and well proven cyber risk management framework, the structure of this recommendation has been laid out taking inspiration from the structure of the “Framework for Improving Critical Infrastructure Cybersecurity” published by the National Institution of Standards and Technology (NIST), also known as the “NIST Cybersecurity Framework” (NIST-CSF). In particular, the “Framework Core” described in Appendix A of the aforementioned document has been considered.

The functions (Identity, Protect, Detect, Respond and Recover) and the categories indicated in NIST-CSF’s Appendix A have been adapted and customized for the specific application to networks connecting computer based systems onboard ships.

The roles and responsibilities indicated in the recommendation have been identified taking into account the stakeholders typically involved in the various phases of a ship’s life, with particular focus on the building and service phases, which are the most important phases for network security.

The documentation to be provided and retained, as indicated in the recommendation, has been selected in order to be a reference for tracing the items and the activities subject to network security, and to provide the Class Society with means for a prompt and easy verification of safeguards and countermeasures put in place.

3. Source/derivation of the proposed IACS Resolution

The following international or industrial standards have been considered as a technical background for this recommendation.

1. IMO MSC-FAL.1/Circ.3, "Guidelines on Maritime Cyber Risk Management", July 2017
2. ISO/IEC 27001:2013, "Information technology – Security techniques – Information security management systems – Requirements", 2013
3. NIST "Framework for Improving Critical Infrastructure Cybersecurity", version 1.1, 2017
4. "The Guidelines on Cyber Security On board Ships", version 2.0, BIMCO, CLIA, ICS, INTERCARGO, INTERTANKO, OCIMF and IUMI, 2017
5. "The CIS Critical Security Controls for Effective Cyber Defense", version 6.0, Center of Internet Security, October 2015
6. ISO/IEC 27033-1:2015, "Information technology, Security techniques – Network security – Part 1: Overview and concepts", 2015
7. IACS UR E22 "On Board Use and Application of Computer Based Systems", June 2016

4. Summary of Changes intended for the revised Resolution:

N/A

5. Points of discussions or possible discussions

- Risk based approach has been discussed and revised in the development of the Recommendation within the Small Team. The initial approach has been revised and partially abandoned.
- Roles and responsibilities have been discussed during the Panel meeting and later by GPG. After Panel discussion, a generic attribution of responsibility was agreed. After comments from GPG, roles and responsibilities have been defined more clearly for each activity.

6. Attachments if any

None

Recommendation No. 160 "Vessel System Design"

Summary:

The objective of the recommendation is to develop broad guidelines on vessel system design. The recommendation broadly covers various aspects from design to installation phases, which should be addressed by the system integrator and yard.

Part A. Revision History

Version no.	Approval date	Implementation date when applicable
New (Nov 2018)	27 November 2018	-

- **New (Nov 2018)**

.1 Origin of Change:

- Other (*developed according to roadmap of IACS cyber system panel*)

.2 Main Reason for Change:

N/A

.3 List of non-IACS Member Classification Societies contributing through the TC Forum and/or participating in IACS Working Group:

N/A

.4 History of Decisions Made:

- Ref. to Form A of Cyber Systems Panel Task no. PC17008.
- Development of first draft made by the Small Team, conducted via correspondence and face-to-face meetings. The team members are: RS (lead), KR, LR, PRS
- Revised and agreed by the Cyber Systems Panel through correspondence.
- Submitted to GPG for appropriate actions on 15 June 2018
- Comments received from GPG on 25 June 2018 and accounted for, as applicable in the current revision
- Forwarded to JWG/CS for review on 30 September 2018
- Resubmitted to GPG for approval on 15 November 2018

.5 Other Resolutions Changes

N/A

.6 Dates:

Original Proposal: 16 January 2017

Made by GPG (16036bIGy).

Panel Approval: 15 June 2018 (Ref: PC17008)

GPG Approval: 27 November 2018 (Ref: 18074_IGI)

Part B. Technical Background

List of Technical Background (TB) documents for Rec 160:

Annex 1. **TB for New (Nov 2018)**

See separate TB document in Annex 1



Technical Background (TB) document for Rec 160 (New Nov 2018)

1. Scope & Objective

Ship board systems have evolved from simple stand-alone systems to integrated systems and usually connected remotely from the vessel to the shore based facilities for data exchange, monitoring or upgrade.

This means that vital systems of vessel e.g. steering system may become affected with some computer/software failures, crew errors in operating of related cyber systems of hijacked remotely.

Cyber security of on-board cyber systems consists in taking physical, organizational, procedural and technical measures to make the network infrastructure connecting Information Technology (IT) and/or Operational Technology (OT) systems resilient to unauthorized access, misuse, malfunction, modification, destruction or improper disclosure, thereby creating a secure platform for such systems to perform their intended functions within a secure environment.

The international shipping industry is complex and while it is traditional it is also constantly evolving and involves vessels of different ages sharing the world's oceans at the same time. Meanwhile, the recent phase of digital technology developments created many opportunities for improvements in safety, environmental and economical vessel operations but sometimes the gains have been won without a full appreciation of the nature and extent of the risks involved.

This has resulted in the current situation where we have many thousands of vessels of different ages, types and sizes each with different states of technology dependence sharing the same transport mode in sometimes very busy waters with limited understanding of how the risks have changed.

The situation cannot be completely resolved immediately but needs to be started and this is begun with new vessels entering service with systems designed with any associated cyber risks understood, quantified, addressed and documented in a manner which permits their proper inspection and maintenance.

This recommendation is intended to provide a minimum set of recommended measures for the design and testing of on-board cyber systems against cyber-related risks, vulnerabilities and threats, including awareness of operators about cyber-security threats and procedures to prevent and react to cyber-attacks.

The objectives for this recommendation is:

- To develop recommendations on design philosophy for cyber systems of vessel;
- To identify requirements for cyber systems of vessel;
- To identify minimum cyber safe practices for cyber systems of vessel;
- To develop recommendation for on board installation and testing of for cyber systems of vessel;
- To identify acceptable standards for equipment of cyber systems of vessel.

This recommendation applies to on-board cyber systems, connecting on-board IT and

OT systems, which are vulnerable to potential cyber events that could lead to dangerous situations for the safety of human life, vessel or cargo, or threat to the environment, or compromise the confidentiality, integrity and/or availability of critical information.

The provisions contained herein apply to the onboard cyber systems according to the definition in UR E22, however the extent and level of application should be proportional to the category of systems connected, considering the highest category as leading.

The extent and level of application may also be affected by additional factors related to the ship as a whole, like type of service and navigation, overall level of digitalization onboard, extension and interconnection of different networks, etc.

This recommendation may be applied to new ships as well as to ships in service.

2. Engineering background for technical basis and rationale

During the first panel meeting, the panel identified twelve subject matters that the panel should focus on and use as the basis of the roadmap developed in response to GPG request (GPG81, FUA no.14), sent on 21 October 2016 (GPG 16188, PC16007).

This recommendation on vessel system design covers the eighth subject.

Shipping is the worldwide, complicated and rapidly growing Industry. Current reality sends to the Industry lots of signs and challenges: it must be safe, clean and economically efficient to continue growing. This leads to introduce modern technologies in the shipbuilding and makes ships more computerized and automatized.

However, unceasing number computers onboard may also become dangerous if these cyber systems become affected with their own failure, crew human errors or attacks from outside.

In many respects the nature of marine installations are quite different from those faced in most industries. There is normally no 'fail-safe' option for the vessel as the continued availability of propulsion power and steering are critical to safety. However, there are already many aspects of familiar vessel design that provide 'alternative means' and/or emergency services, plus a vessel cannot easily be physically approached while at sea. Some of these characteristics can be used to advantage when considering cyber threats, if they are considered and configured as part of a larger strategy, during design.

In addition to rules and requirements covering safety and security the Industry now is being faced with cyber safety and security – quite new and vague for many humans, but not less important than others.

It is observed that even when such in-depth study is carried out during design phase, there are rarely documented and reviewed by classification societies. As a result, when subsequent modifications are carried out on ship systems to meet new demands or change in technology, the original intent /design criterion is rarely considered during modifications.

The recommendations are applicable to vessel's systems using digital communication to interconnect systems within the ship or from the ship to equipment or networks off the ship. The interconnection may be intended only for monitoring (read only) or for control or for the creation of new functionality with integrated systems.

3. Source/derivation of the proposed IACS Recommendation

The following international or industrial standards have been considered as a technical background for this recommendation.

1. IMO MSC-FAL.1/Circ.3, "Guidelines on Maritime Cyber Risk Management", July 2017
2. ISO/IEC 27001:2013, "Information technology – Security techniques – Information security management systems – Requirements", 2013
3. NIST "Framework for Improving Critical Infrastructure Cybersecurity", version 1.1, 2017
4. IACS UR E22 "On Board Use and Application of Computer Based Systems", June 2016

4. Summary of Changes intended for the revised Recommendation

None

5. Points of discussions or possible discussions

None

6. Attachments if any

None

Recommendation No. 161

“Inventory List of computer based systems”

Summary:

This IACS Recommendation contains recommended information to be included in an inventory list for computer based systems and recommendations for updating the list.

Part A. Revision History

Version no.	Approval date	Implementation date when applicable
New (Sep 2018)	21 September 2018	-

- **New (Sep 2018)**

.1 Origin of Change:

- Other (*Origin developed during the first panel meeting and the roadmap*)

.2 Main Reason for Change:

N/A

.3 List of non-IACS Member Classification Societies contributing through the TC Forum and/or participating in IACS Working Group:

N/A

.4 History of Decisions Made:

A first draft was released by the small team in November 2017, commented by the panel members and a version was delivered to the panel in February 2018 and then to the GPG.

The draft Recommendation agreed by GPG was forwarded to JWG/CS for review 24 May 2018 and the revised draft Recommendation was resubmitted to GPG for approval on 16 July 2018.

.5 Other Resolutions Changes

N/A

.6 Dates:

Original Proposal: October 2016 Made by Cyber Systems Panel
 Panel Approval: February 2018 (Ref: PC17009)
 GPG Approval: 21 September 2018 (Ref: 17165_IGI)

Part B. Technical Background

List of Technical Background (TB) documents for Rec 161:

Annex 1. **TB for New (Sep 2018)**

See separate TB document in Annex 1



Technical Background (TB) document for Rec 159 (New Sep 2018)

1. Scope and objectives

1. To develop list of information to be included in the inventory list for computer based systems.
2. To develop criteria in order to exclude some equipment considered as non-relevant from the cyber systems inventory list.
3. To establish criteria and involved stakeholders for updating the list and identify the extent to which the updated list should be communicated to the Class Society.
4. To identify acceptable supports for this inventory.

2. Engineering background for technical basis and rationale

During the first panel meeting, the panel identified twelve subject matters that the panel should focus on during the following twelve months. These twelve subject matters were prioritized and were used as the basis of the roadmap developed in response to GPG request (GPG81, FUA no.14), sent on 21 October 2016 (GPG 16188, PC16007).

In order for effective assessment and control of the cyber systems on board an inventory of all of the vessel's equipment and systems needs to be created during the vessel's design and construction and updated during the life of the ship. The inventory will also be useful to provide adequate detail relating to the subsystem components. In order to support this, the Recommendation will indicate the information that should be provided by equipment suppliers in order to support the shipbuilder.

Main topics that were discussed between the Panel were:

- list of references: it was decided to add IMO Circular MSC-FAL.1/Circ.3
- the responsibilities of creating and updating the inventory list during the ship life have been clarified. If no entity is assuming the role of system integrator during the ship life, the owner should be able to provide an update Inventory List.

3. Source/derivation of the proposed IACS Resolution

- The 9th subject on the roadmap which finally approved from GPG in their email sent on 16 January 2017 (GPG 16036blGy).

4. Summary of Changes intended for the revised Resolution:

N/A

5. Points of discussions or possible discussions

The possibilities of excluding some systems of this list has been clarified: systems not connected to category II or III systems and not being category II or III systems according to UR E22 might be excluded.

6. Attachments if any

None

Recommendation No. 162 "Integration"

Summary:

This IACS recommendation suggests recommendations for safe operation of ships' essential systems in integrated networks.

Part A. Revision History

Version no.	Approval date	Implementation date when applicable
New (Sep 2018)	21 September 2018	-

- **New (Sep 2018)**

.1 Origin of Change:

Other (*developed according to roadmap of IACS cyber system panel*)

.2 Main Reason for Change:

N/A

.3 List of non-IACS Member classification societies contributing through the TC Forum and/or participating in IACS Working Group:

N/A

.4 History of Decisions Made:

Form A approved by GPG under 18073_IGd dated 23 May 2018.

The draft Recommendation agreed by GPG was forwarded to JWG/CS for review 31 May 2018 and the revised draft Recommendation was resubmitted to GPG for approval on 16 July 2018.

.5 Other Resolutions Changes

N/A

.6 Dates:

Original Proposal: 15 December 2017 Made by Cyber Systems Panel
 Panel Approval: 26 April 2018 (Ref: PC17010)
 GPG Approval: 21 September 2018 (Ref: 18073_IGk)

Part B. Technical Background

List of Technical Background (TB) documents for Rec 162:

Annex 1. **TB for New (Sep 2018)**

See separate TB document in Annex 1



Technical Background (TB) document for Rec 162 (New Sep 2018)

1. Scope and objectives

1. To define integration of systems;
2. To identify recommendations regarding separation of safety functions from other functions in integrated systems;
3. To identify recommendations regarding autonomy of each network segment;
4. To identify recommendations regarding redundancy and proper operation after single failure related to a cyber event;
5. To identify recommendations regarding safety for usage of different interfaces in integrated systems;
6. To identify recommendations regarding safe operation of integrated system.
7. To identify recommendations regarding tests of integrated system.

2. Engineering background for technical basis and rationale

During the first panel meeting, the panel identified twelve subject matters that the panel should focus on during the following twelve months. These twelve subject matters were prioritized and were used as the basis of the roadmap developed in response to GPG request (GPG81, FUA no.14), sent on 21 October 2016 (GPG 16188, PC16007). After further correspondence and revisions to the roadmap, it received its final approval from GPG in their email sent on 16 January 2017 (GPG 16036bIGy).

This task on Integration covers the 10th subject.

There is a need to develop recommendations for safe operation of Ship's essential systems in integrated network. Lack of knowledge in this scope by Shipyards and Ship Owners gives possibility that after systems are integrated (connected to each other) less important systems can become an open way to attack essential systems or cause their failures (even unintentionally). Also there is uncontrolled way how the integration process is going. It is necessary to develop recommendations for this process and show how and when integration can be verified by each Class Society.

3. Source/derivation of the proposed IACS Resolution

The following international or industrial standards have been considered as a technical background for this recommendation.

- Class Societies Rules for Classification and Construction of Sea-going Ships
- ISO/IEC 27001:2014 Information technology – Security techniques – Information security management systems – Requirements
- The Guidelines on Cyber Security onboard Ships (Version 2.0: BIMCO, CLIA, ICS, INTERCARGO, INTERTANKO, OCIMF and IUMI)
- IEC 61158 - Industrial communication networks - Fieldbus specifications - Part 1: Overview and guidance for IEC 61158 and IEC 61784 series
- IEC 61784 - Industrial communication networks - Profiles - Part 3: Functional safety fieldbuses - General rules and profile definitions
- IEC 62443 - Industrial communication networks – Network and system security – Part 2-1: Establishing an industrial automation and control system security program

4. Summary of Changes intended for the revised Resolution:

N/A

5. Points of discussions or possible discussions

5.1 Small Team (PRS, BV, RINA, IRS) discussions by email

- 1) Overlaps with other Recs discussions. It was indicated as subject for last stage – after all Recs are developed.
- 2) Application of recommendations for existing Ships discussions. It was indicated by PRS that this task covers only new ship buildings.
- 3) DLP subject discussions. We analyzed if specific or independent should be recommended for each system/network.
- 4) Antivirus for PLCs and other equipment without typical operating system subject discussions. It was decided to prepare answers for next panel meeting.
- 5) Definitions discussions including very important definition for integrated network. Some minor changes were proposed and introduced.

5.2 Small Team discussions during 5th CS Panel meeting

- 1) Antivirus for PLCs and other equipment without typical operating system subject detailed discussions were performed. It was agreed that each manufacturer should propose how the equipment is to be secured.
- 2) Discussions concerning segmentation (during integration process) were performed. It was decided to use IEC62443-2-1 Standard for this purpose (level 1 to level 4).

5.3 Panel discussions (all Panel Members) by email

All comments were analyzed by PRS and answers presented. Main subjects were:

- physical separation and separation on VLANS
- firewall between onboard network and external network
- segmentation

Some changes were introduced to final document developed on 26 April 2018.

5.4 Possible discussions

There might be some overlaps in all twelve Recommendations which are developed by CS Panel. After all Recommendations are finished there is necessary to review all documents and discuss changes cause by these overlaps.

6. Attachments if any

None

Recommendation No. 163 "Remote Update/Access"

Summary:

This recommendation provides a minimum set for recommendations/procedures for:

- Remote connection to system on shore.
- Remote maintenance, including clear procedures and protective measures, which include mechanisms for validating updates prior to preceding and simply revert to earlier revisions in the case of corruption.

Part A. Revision History

Version no.	Approval date	Implementation date when applicable
New (Sep 2018)	21 September 2018	-

- **New (Sep 2018)**

.1 Origin of Change:

- Other (*Suggestion by IACS Cyber Systems Panel*)

.2 Main Reason for Change:

N/A

.3 List of non-IACS Member classification societies contributing through the TC Forum and/or participating in IACS Working Group:

N/A

.4 History of Decisions Made:

- Ref. to Form A of Cyber Systems Panel Task no. PC17011.
- Development of first draft made by the Small Team, conducted via correspondence and discussions. The team members are: CRS (lead), CCS, DNV GL, RS.
- Revised and agreed by the Cyber Systems Panel.
- Submitted to GPG for appropriate actions on 27 April 2018.
- Forwarded to JWG/CS for review on 31 May 2018.
- Resubmitted to GPG for approval on 16 July 2018.

.5 Other Resolutions Changes:

N/A

.6 Dates:

Original Proposal: April 2018 Made by the Cyber Systems Panel

Panel Approval: 27 April 2018 (Ref: PC17011)

GPG Approval: 21 September 2018 (Ref: 18050_IGI)

Part B. Technical Background

List of Technical Background (TB) documents for Rec 163:

Annex 1. **TB for New (Sep 2018)**

See separate TB document in Annex 1



Technical Background (TB) document for Rec 163 (New Sep 2018)

1. Scope and objectives

The objectives of this recommendation are:

- To provide a minimum set of recommendations/procedures for remote connection to system on shore.
- To provide a minimum set of recommendations/procedures for remote maintenance, including clear procedures and protective measures, which include mechanisms for validating updates prior to preceding and simply revert to earlier revisions in the case of corruption.

This recommendation is relevant to new construction ships, and may be used as guidance for existing ships, which connect to remote services and systems on shore for: monitoring, diagnosis and remote maintenance.

2. Engineering background for technical basis and rationale

During the first Cyber Systems Panel meeting, the panel identified twelve subject matters that the panel should focus on and use as the basis of the roadmap developed in response to GPG request (GPG81, FUA no.14), sent on 21 October 2016 (GPG 16188, PC16007).

This recommendation on Remote Update/Access covers the 11th subject.

Information and communications technology (ICT) is revolutionising shipping, bringing with it a new era – the ‘cyber-enabled’ ship. Many ICT systems on-board ships connect to remote services and systems on shore for monitoring of systems, diagnosis and remote maintenance, creating an extra level of complexity and risk. ICT systems have the potential to enhance safety, reliability and business performance, but there are numerous risks that need to be identified, understood and mitigated to make sure that technologies are safely integrated into ship design and operations.

Modern technologies can add vulnerabilities to the ships and the threat of their exploitation is increased when care has not been taken to provide secure of networks and properly controlled access to the internet. Additionally, shoreside and onboard personnel may be unaware of how some equipment producers maintain remote access to shipboard equipment and its network system. The risks of misunderstood, unknown, and uncoordinated remote access to an operating ship should be taken into consideration as an important part of the risk assessment.

Taking into account all above, it is crucial to establish recommendations/procedures for control over remote access to onboard Information Technology (IT) and Operation Technology (OT) systems. Clear guidelines should establish who has permission to access, when they can access, and what they can access.

The documentation to be provided and retained, as indicated in the recommendation, has been selected in order to be a reference for tracing the items and the activities subject to remote update/access, and to provide the Class Society with means for a prompt and easy verification of safeguards and countermeasures put in place.

3. Source/derivation of the proposed IACS Resolution

The following international or industrial standards have been considered as a technical background for this recommendation:

1. "The Guidelines on Cyber Security On board Ships", version 2.0, BIMCO, CLIA, ICS, INTERCARGO, OCIMF and IUMI, 2017
2. ISO/IEC 27002:2013, "Information technology – Security techniques – Code of practice for information security controls"
3. NIST SP 800 series – Computer security
4. IACS UR E22 "On Board Use and Application of Computer Based Systems", June 2016

4. Summary of Changes intended for the revised Resolution:

N/A

5. Points of discussions or possible discussions

The Recommendation was made through correspondence and discussions within the Cyber Systems Panel which mainly incorporating individual comments and accepting the consolidated text.

6. Attachments if any

None

Recommendation No. 164 “Communication and Interfaces”

Summary:

This Recommendation on Communication and Interfaces aims to establish recommendations for control over communication paths and connections to onboard Information Technology (IT) and Operation Technology (OT) systems.

It provides guidance on communication paths and onboard IT/OT systems for existing ships that provide connections to computer-based services and systems ashore, and to new construction ships with integrated systems provided by the builder or integrator.

Part A. Revision History

Version no.	Approval date	Implementation date when applicable
New (Nov 2018)	27 November 2018	-

- **New (Nov 2018)**

.1 Origin of Change:

- Other (*developed according to roadmap of IACS cyber system panel*)

.2 Main Reason for Change:

N/A

.3 List of non-IACS Member Classification Societies contributing through the TC Forum and/or participating in IACS Working Group:

N/A

.4 History of Decisions Made:

- Ref. to Form A of Cyber Systems Panel Task no. PC17012.
- Development of first draft made by the Small Team, conducted via correspondence and face-to-face meetings. The team members are: ABS (lead), KR, LR, NK.
- Revised and agreed by the Cyber Systems Panel through correspondence on 15 June 2018.
- Submitted to GPG for appropriate actions on 15 June 2018.
- Comments received from GPG on 30 June 2018 and accounted for, as applicable in the current revision
- Forwarded to JWG/CS for review on 30 September 2018
- Resubmitted to GPG for approval on 15 November 2018

.5 Other Resolutions Changes

N/A

.6 Dates:

Original Proposal: 16 January 2017 Made by GPG (16036bIGy).

Panel Approval: 15 June 2018 (Ref: PC17012)

GPG Approval: 27 November 2018 (Ref: 18052_IGi)

Part B. Technical Background

List of Technical Background (TB) documents for Rec 164:

Annex 1. **TB for New (Nov 2018)**

See separate TB document in Annex 1



Technical Background (TB) document for Rec 164 (New Nov 2018)

1. Scope and objectives

1.1 Scope

This Recommendation provides guidance on communication paths and onboard IT/OT systems for existing ships that provide connections to computer-based services and systems ashore, and to new construction ships with integrated systems provided by the builder or integrator.

Shipboard equipment and associated integrated systems to which these recommendations apply can include, but are not limited to:

- Ship control networks;
- Critical systems that may not always be connected (e.g., navigation systems);
- Propulsion networks;
- Safety-critical systems;
- Cargo management systems and networks;

1.2 Objectives

This Recommendation is intended to provide minimum recommendations/procedures for Communications and Interfaces protection and management in order to:

- Develop criteria that help define which interconnections / interfaces are permitted or prohibited.
- Develop methods for safe communication and interface between computer-based systems.
- Develop recommendations for testing of communication paths for functional and security purposes.
- Develop recommendations relating to the application of suitable logs for periodic validation and continuous update of all routes into the systems in order to assess the acceptability of modifications and review appropriate procedures for addressing the associated risks.

2. Engineering background for technical basis and rationale

During the first panel meeting, the panel identified twelve subject matters that the panel should focus on and use as the basis of the roadmap developed in response to GPG request (GPG81, FUA no. 14), sent on 21 October 2016 (GPG 16188, PC17012).

This recommendation on Communication and Interfaces covers the twelfth subject. Shipboard information flows enable the automation systems found in shipboard Information and Communications Technology (ICT). Communications among components, and the system interfaces and protocol converters that allow those components to exchange information, are critical to systems and ship success.

Because communications capabilities and flows enable operations in the IT/OT supporting crews and ship systems, these functions must be safeguarded to ensure proper, authorized operations. Communications faults or failures may cause operational disconnects, improper decisions or actions. This is especially true for highly-automated vessels or systems, and their communications paths must be kept secure for the safety of ship, crew and the environment. All these communications and interfaces increase the possibility of computer system faults and extend the fault from one system to another system.

It is necessary to consider recommendations relating to the permitted and prohibited interconnections, regulating and managing access across interfaces, potential protective functions to safeguard external and internal protective functions and testing of communication paths for functional and security purposes. This Recommendation on Communication and Interfaces aims to establish recommendations for control over communication paths and connections to onboard Information Technology (IT) and Operation Technology (OT) systems.

2.1 Communications systems for ship or offshore data exchange

Ship systems supporting offboard external communications center on satellite communications systems (SATCOM) and on conventional radio frequency (RF) systems.

SATCOM may include voice, video and data communication channels as part of service to the vessel. RF systems are generally voice only, controlled only onboard the ship from specific locations, such as the bridge or radio room. Note that there exist some very limited-bandwidth long-range RF data systems, but these are relatively uncommon and will not be addressed as a separate system type.

SATCOM systems will provide service through a service provider ashore that manages the transmission path from the transmit/receive ground station to and from the Internet. The vessel will have a contracted service level agreement (SLA) for quality of service and level of service (bandwidth, service types, etc.) provided for the vessel and crew.

SATCOM providers have an obligation to protect data transmissions and privacy of vessel data streams, and this obligation will be detailed in the contract between the owner and that service provider. Additional protections for data, beyond transmission security, will be the responsibility of the owner. This may include any of various types of data encryption methods available to protect the data streams upon transmission from the ship to shore, or from shore transmission station to the ship, via the service provider's network.

2.2 Networking concepts and Internet Protocol communications to ships

Ships with data service provided via SATCOM service will handle data through their point of presence (PoP) router, which will be the first reception point inside the skin of the ship downstream from the system antenna. The PoP router connects to a firewall and/or proxy to filter the traffic flows (both inbound and outbound, based on rules established by the owner or operator), then to a network switch, to which the various shipboard networks attach. The several networks that connect to the main switch may include

- Engineering, both for sensor reporting or performance monitoring, and for specialized and limited connections to engineering systems;
- Ship control and navigation;
- Cargo management and monitoring;
- General purpose, administrative and crew entertainment; and
- Remote offboard and/or unmanned vehicle control and management.

Other, more specialized and limited networks, may be present as well. Note that all networks should be segregated from one another by default, and only accessible from one to another by deliberate decisions of the owner and/or crew to support ship safety and operations.

Networks will connect the main switch to their systems and equipment by standard interfaces and transmission media. Ethernet and Industrial Ethernet are common transmission media such as Transmission Control Protocol / Internet Protocol (TCP/IP) and User Datagram Protocol (UDP) networking. More specialized connection media may be required for serial protocols used for engineering systems; but all interfaces to the ship's main switch will be by Ethernet.

Separated networks, called enclaves or segments (such as VLAN), may not be allowed to connect to outbound communications. Some segments may include sensor networks and their data processing, or propulsion equipment. Separating networks from the general purpose network services onboard does not necessarily keep these nets and their equipment safe; crew procedures and physical safeguards are still required to ensure that data is only transferred to or from these systems by authorized personnel using authorized means.

Interfacing to systems across networks may be as simple as opening applications from one network address to another, or it may be as complicated as loading new propulsion plant control software through locked and guarded ports (such as Universal Serial Bus (USB)) that have special procedures required by crew or company policy. Boundary management is very important to keep people, systems, ship functions and data safe. Boundaries on networked systems include human interfaces, like keyboards and pointing devices (mice, screen pens, digitizing pads), computer ports and connection mechanisms, and network interfaces that can be used by other machines.

These connections must be known, tracked and consciously managed to ensure security and safety of the systems is maintained. Access controls for communication and interface mechanisms is an important part of maintaining safety and security, and this includes controls for both humans and machines with access to specific systems. Just as physical access is managed shipboard, logical access to computer systems must be managed in the same way. Know the communications path, know the accesses, know the personnel and systems allowed to communicate or access systems – and the ship's security will be better for it.

Sensor networks, installed for the multitude of purposes for data collection and reporting across the ship, will become more common as Industrial Internet of Things (IIoT) becomes widely distributed in the maritime industries. Sensor devices are small computers that will have TCP/IP communications paths for data and instructions; they must be treated as valuable parts of the ship and its systems, and safeguarded appropriately, both physically and logically. Sensors must be installed and operated to only allow communication to and from authorized nodes and/or

personnel, and their data is critical to the ship's operations. Sensor access must be carefully managed to ensure no safety-critical systems can be compromised by inadvertent or deliberate activity with sensor computers.

Internal communications systems, whether intercom, broadcast (MC), wireless voice (RF), telephone, or wireless voice over Internet Protocol (VoIP), are sometimes connected to shipboard networks also. Some of these paths and interfaces may include data transmission paths for cargo management or monitoring systems, or they may also include telemetry or data links to special-purpose systems with sensitive operating limits, such as liquid-gas refrigeration systems.

Mobile devices, whether portable data devices for shipboard operations, or mobile phones, will connect to internal communications networks as well. Given the wide acceptance of mobile phones and smart phones through the maritime industries, it is important that these devices be consciously managed through policies in the same way as all other internal communications paths and interfacing systems.

3. Source/derivation of the proposed IACS Resolution

The following international or industrial standards have been considered as a technical background for this recommendation.

1. UR E22 – On Board Use and Application of Computer based systems
2. NIST SP 800 series – Computer security
3. BIMCO – The Guidelines on Cyber Security onboard Ships
4. ANSSI – Cyber security Assessment and protection of ship
5. IEC 61162 – Maritime navigation and radio communication equipment and systems – Digital interfaces. Part 450: Multiple talkers and multiple listeners – Ethernet interconnection. Part 460: Multiple talkers and multiple listeners – Ethernet interconnection – Safety and security
6. IEC 62443-3-3 Industrial communication networks – Network and system security. Part 3-3: System security requirements and security levels
7. ISO/IEC 27001 – Information technology – Security techniques – Information security management systems - Requirements
8. ISO/IEC 27002 – Information technology – Security techniques – Code of practice for information security controls
9. ISO 16425 – Ships and marine technology – Guidelines for the installation of ship communication networks for shipboard equipment and systems

4. Summary of Changes intended for the revised Resolution

None

5. Points of discussions or possible discussions

None

6. Attachments if any

None

Recommendation No. 165

“Recommendation for assessing design instances based on application of alternative methods in the hull structural design of CSR ships”

Summary

This recommendation provided clarifications on the scope and documentation to trace for assessing alternative (novel) design instances and conventional designs based on application of alternative (novel) design methods for the hull structural design appraisal of CSR ships when there is not full and direct compliance to CSR-BC&OT due to innovative designs that are not capable of being directly evaluated with the existing Rules and/or IACS resolutions.

Part A. Revision History

Version no.	Approval date	Implementation date when applicable
Rev.1 (Jan 2022)	28 January 2022	-
New (Nov 2018)	03 November 2018	-

Rev.1 (Jan 2022)

1 Origin of Change:

- Request by non-IACS entity (*IMO GBS auditor*)
- Suggestion by IACS member

2 Main Reason for Change:

Following GBS maintenance audit in 2019 by IMO GBS auditor, it was concluded that there is no sufficient evidence that clear criteria and techniques for assessing alternative methods used in the design have been established in the IACS rule set and, therefore, also in the individual rule set of the submitters which mandatorily implement IACS Rec. 165 to satisfy FR 10.3.2 into their individual rule set. IACS have received “non-conformity” as findings of GBS audit.

3 List of non-IACS Member classification societies contributing or participating in IACS Working Group:

None

4 History of Decisions Made:

According to the recommendation of the GBS Audit Team, the non-conformities should be rectified, and all remaining observations should be addressed. Therefore EG/GBS and PT PH32 (CSR BC&OT Maintenance Team) who are the responsible for this observation, have prepared the GBS CAP (Corrective Action Plan) including a revision

of Rec. 165. Rev.1 of Rec.165 was prepared by PT-GBS and discussed further by PT PH32, EG/GBS and Hull Panel. Rec. 165 is providing guidance for the assessment of alternative (novel) design instances and conventional designs for which alternative (novel) design methods (technology) or alternative design and calculation methods were applied during the design process. Alternative (novel) design instances need to be checked by applying the guidance in IMO MSC.1/Circ.1455.

5 Other Resolutions Changes

None

6 Any hinderance to MASS, including any other new technologies:

None

7 Dates:

Original Proposal: 7 October 2021 Made by PT/GBS

Panel Approval: 21 January 2022 (Ref: 19202nEGg)

GPG Approval: 28 January 2022 (Ref: 19202nIGs)

• New (Nov 2018)

.1 Origin of Change:

- Request by non-IACS entity (*IMO GBS auditor*)
- Suggestion by IACS member

.2 Main Reason for Change:

Following GBS compliance audit by IMO GBS auditor, it was concluded that there is no established document which include the clear criteria and techniques for assessing alternative methods used in the hull structural design then IACS have received "observation" as Findings of GBS audit.

.3 List of non-IACS Member Classification Societies contributing through the TC Forum and/or participating in IACS Working Group:

None

.4 History of Decisions Made:

According to the recommendation of the GBS Audit Team, the non-conformities should be rectified, and all remaining observations should be addressed. Therefore EG/GBS and PT PH32 (CSR Maintenance Team) who are the responsible for this observation, has prepared the GBS CAP (Corrective Action Plan) including a deliverable of a standard procedure to assess alternative methods with appropriate criteria and techniques, and it was submitted to IMO in December 2015.

.5 Other Resolutions Changes

None

.6 Dates:

Original Proposal: 16 November 2016

Made by PT PH32

Panel Approval: 21 September 2018 (Ref: PH15016)

GPG Approval: 03 November (Ref: 17166bIGk)

Part B. Technical Background

List of Technical Background (TB) documents for Rec.165:

Annex 1. **TB for Rev.1 (Jan 2022)**

See separate TB document in Annex 1.



Note: There is no separate Technical Background (TB) document available for New (Nov 2018).

Technical Background (TB) document for Rec.165 (Rev.1 Jan 2022)

1. Scope and objectives

1. To rectify non-conformity IACS/2019/Maint/NC/1, stemming from 2nd GBS maintenance audit in 2019;
2. To clarify scope and objectives of Rec.165;
3. To differentiate between the application of alternative design methods and novel (alternative) design instances;

2. Engineering background for technical basis and rationale

The work on Rev.1 of Rec.165 was initiated by the non-conformity reported by the audit team as a result of the 2nd GBS maintenance audit held in 2019 (ref. MSC 102/7/2).

The non-conformity states that the audit did not find sufficient evidence that clear criteria and techniques for assessing alternative methods used in the design have been established in the IACS rule set and, therefore, also in the individual rule set of the submitters which mandatorily implement IACS Rec. 165 to satisfy FR 10.3.2 into their individual rule set.

2.1 Alternative design

The handling of alternative designs was discussed during an IMO-IACS-GBS auditors workshop held in July 2021. The outcome of this workshop is reported in MSC 104/INF8. In paragraph 20 of this paper, it is stated:

“With respect to the handling of "alternative methodology" and "novel designs" for GBS audits, it was clarified that these were sufficiently addressed in the Guidelines for the approval of alternatives and equivalents as provided for in various IMO instruments (MSC.1/Circ.1455), whereby a flag Administration would consider the approval of a novel/alternative design first, followed by a communication of such approval to the Organization with the aim of formalizing compliance of such design with IMO requirements.” The basis for that decision is that ships under GBS for Bulk Carriers and Oil Tankers need to comply with SOLAS II-1/3-10, which states that the GBS requirements given in paragraphs 2 to 2.5 shall be achieved through satisfying applicable structural requirements of an organization which is recognized by the Administration in accordance with the provisions of regulation XI-1/1, or national standards of the Administration, conforming to the functional requirements of the Goal-based Ship Construction Standards for Bulk Carriers and Oil Tankers. This means alternative design instances not in direct compliance with rules conforming with IMO GBS (e.g. IACS CSR BC&OT) are at the same time not in compliance with SOLAS II-1/3-10. Therefore, the approval of such design instances needs to be considered by flag administration. The assessment of equivalency to the GBS functional requirements of such a design instances may be based on MSC.1/Circ.1455.

MSC.1/Circ.1455 provides a matrix which can be used for the categorization of new technology. Based on the categorization, the extent of the analysis to demonstrate an equivalent level of safety compared with existing rules and regulations can be decided.

The table is given below for easy reference:

Table 1 Categorization of new technology from MSC.1/Circ.1455

Table 1: Categorization of new technology				
		Technology status		
		Proven	Limited field history	New or unproven
Application Area		1	2	3
Known	0	1	2	3
New	1	2	3	4

With respect to GBS and alternative (novel) design instances this table can be translated as follows:

Table 2 Categorization of alternative (novel) structural design instance in context with GBS and IACS CSR

Application Area of Technology		Technology Status (Applied Design and fabrication methodologies)		
		Proven (following CSR BC&OT ²⁾)	Limited Field History	New or unproven
		1	2	3
Known (intent of the CSR BC&OT ¹⁾)	0	1 (just CSR / GBS)	2	3
New (outside CSR BC&OT)	1	N.A. ³⁾	3	4

¹⁾ An area of application which is covered by CSR BC&OT requirements

²⁾ Following CSR BC&OT requirements or related standards like UR's etc. or requirements of individual society

³⁾ This is not applicable, as a new field of application, which is not covered by the CSR BC&OT will of course not have requirements in the CSR BC&OT or related standards.

In Table 2 Category 1 means just the application of GBS compliant rules (application of IACS CSR BC&OT).

Category 2 is related to technologies that are already applied in other branches, technologies that are fully investigated by research but have limited experience in application. In addition, the technology is applied to a known, well-regulated application area. That means the application area, where the new technology will be applied in the design instance is covered by rule requirements. Equivalency check is to be carried out to show that the application of the new technology will be compliant with the intent of the existing rule requirements.

Regarding ship structure examples of category 2 can be application of alternative (novel) design methods (see below), the substitution of the usual material by another material e.g. substitution of steel in the superstructure by aluminium or similar. Failure modes that are covered by the rules have to be checked against equivalent criteria for the new technology e.g. equivalent criteria against yield, buckling and fatigue failure in case of usage of new material.

For category 3 there are two possibilities

- a) New or unproven technology is applied to the design in an area, where rule requirements can be applied. Example could be new production methodology

e.g. bonding or additive manufacturing for some structural elements / parts. Design changes might be necessary in order to apply the new technology, however the area, where it is applied is covered by the structural rule requirements. This is somewhat similar to Cat 2 above with the difference that there is no experience in the application of this technology available. Therefore, additional investigations might be necessary to establish the equivalent criteria to what the design could be finally approved.

- b) An application of a new technology with some application experience in other areas to a bulk carrier or oil tanker. In that case this is not covered by the rules. From structural point of view a major design change could be under this option e.g. application of new propulsion system, which requires certain larger structural changes which are not covered by the existing rule requirements.

Category 4 in Table 2 is related to the application of a new or unproven technology which finally cannot be covered by the existing regulations. Related to the structural design instance of a ship this will be outside of the scope of CSR BC&OT and GBS as the designs to what the requirements are applicable are well defined.

2.2 Application of alternative methods in the design

Contrary to the alternative (novel) design instance, the application of an Alternative (novel) design method is only one-dimensional and already covered by the application of a Methodology with "limited field history" to a known application area or a "new or unproven" methodology to a known application area. Categorization can therefore be made as given in Table 3 below:

Table 3: Categorization in case of application of alternative designs methods in context with GBS and IACS CSR BC&OT

		Methodology Status		
		Proven (Following CSR meth.)	Limited Field History	New or unproven
Application Area		1	2	3
Known	0	1	2	3

With respect to class approval, the designs need to be in line with the CSR BC&OT or needs to be equivalent. That means in principle the application of alternative (novel) design methodologies for the purpose of design will not be directly approved by the Classification society, however the resulting design instances will be approved against the rule requirements. From that perspective the application of alternative (novel) design methods will not change the principal approval process of the design instance.

Evaluation criteria:

The purpose of structural assessment is finally to show equivalence of the design to the rule requirements. For that purpose, evaluation criteria have to be developed and agreed.

As the IACS CSR BC&OT are covering only the ship structure and strength, the evaluation criteria fall into the category:

a) damage to ship structure and related systems – These criteria address the impact that a casualty might have on a ship structure, mechanical systems, etc. These criteria may represent physical effects of an accident.
as defined in MSC Circ.1455 para 5.2.2.2

In CSR BC&OT the application of alternative design and calculation methods is limited by CSR-BC&OT Pt1 Ch1 Sec2 [5.5.4], which states “The scantlings defined by the prescriptive requirements are not to be reduced by any form of alternative calculations such as FE analysis (FEA), unless explicitly stated.”
The CSR BC&OT allow explicitly for alternative design and calculation methods in the requirements given in Table 4 below:

Table 4: CSR BC&OT requirements for which application of alternative design and calculation methods is allowed.

Rule reference	Details	Alternative design / calculation method	Detail procedure in CSR
Pt 1, Ch 5, Appendix 2	Hull girder ultimate capacity	Direct non-linear finite element analysis	Not available, but items that need to be considered are given
Pt 1, Ch 6, Sec 6, [2.2.2]	Primary supporting members within cargo region for bulk carrier less than 150 m	FEA(Finite Element Analysis)	Yes, CSR FEA procedure can be applied.
Pt 1, Ch 9, Sec 1, [4.5]	Fatigue design standards for alternative design	FEA(Finite Element Analysis)	Yes, CSR FEA procedure can be applied.
Pt 1, Ch 9, Sec 4, [5.3]	Stress concentration factors for alternative design	FEA(Finite Element Analysis)	Yes, detail FEA procedure in [5.3.1]
Pt 1, Ch 9, Sec 6, [2.2]	Equivalent design of stiffener-frame connections	FEA(Finite Element Analysis)	Yes, detail FEA procedure in [2.2]
Pt 1, Ch 10, Sec 1, [2.3.3]	The spacing of web frames and stringers iwo side shell	FEA(Finite Element Analysis)	Yes, CSR FEAprcedure can be applied.
Pt 1, Ch 10, Sec 3, [2.1.4]	The spacing and arrangement requirements	FEA(Finite Element Analysis)	Yes, CSR FEAprcedure can be applied.
Pt 1, Ch 11, Sec 1, [3.2.5]	Arrangements of deck girders and transverses	Grillage or FEA(Finite Element	Yes, CSR FEAprcedure can be applied.

		Analysis)	
Pt 2, Ch 1, Sec 4, [4.1.2]	Primary supporting members in cargo hold structures, subjected to lateral pressure for ships having a length L less than 150 m	Grillage or FEA(Finite Element Analysis)	Yes, CSR FE procedure can be applied.
Pt 2, Ch 2, Sec 3, [1.5.4]	Deck transverses fitted above the upper deck	FEA(Finite Element Analysis)	Yes, CSR FE procedure can be applied.

3. Source/derivation of the proposed IACS Resolution

Rev.1 of Rec.165 was drafted based on the engineering background explained above.

The following documents have been considered as a technical background for this recommendation.

- MSC.1/Circ.1455 Guidelines for the approval of alternatives and equivalents as provided for in various IMO Instruments
- MSC 104/INF.8 Outcome of GBS workshop, submitted by IACS and the Secretariat
- IACS Common Structural Rules for Bulk Carriers and Oil Tankers

4. Summary of Changes intended for the revised Resolution:

N/A

5. Points of discussions or possible discussions

None

6. Attachments if any

None

Recommendation No. 166 “Recommendation on Cyber Resilience”

Summary

The Rec 166 (Corr.2) incorporates the new paragraph 1.1.6 to specify the relation between the Rec 166 and the new UR E26 Cyber Resilience of Ships.

Part A. Revision History

Version no.	Approval date	Implementation date when applicable
Corr.2 (Apr 2022)	11 April 2022	-
Corr.1 (July 2020)	10 July 2020	-
New (Apr 2020)	24 April 2020	-

- **Corr.2 (Apr 2022)**

1 Origin of Change:

- Based on IACS Requirement UR E26 Cyber Resilience of Ships

2 Main Reason for Change:

Specify the relation between the Rec. No.166 and the new UR E26 Cyber Resilience of Ships

3 List of non-IACS Member classification societies contributing or participating in IACS Working Group:

None

4 History of Decisions Made:

None

5 Other Resolutions Changes:

None

6 Any hinderance to MASS, including any other new technologies:

None

7 Dates:

Original Proposal	: 20 October 2021	(Ref: PC20007_ICp)
Panel Approval	: 22 November 2021	(Ref: PC20007_ICr)
GPG Endorsement	: 18 January 2022	(Ref:18197_IGw)
GPG Approval	: 11 April 2022	(Ref: 18197aIGz)

• Corr. 1 (July 2020)

1 Origin of Change:

- Other (Observations from Witherby Publications)

2 Main Reason for Change:

Corrections carried out in recommendation 166 as a consequence of suggestions from Witherby Publications.

3 List of non-IACS Member classification societies contributing or participating in IACS Working Group:

None

4 History of Decisions Made:

None

5 Other Resolutions Changes:

None

6 Any hinderance to MASS, including any other new technologies:

None

7 Dates:

Original Proposal	: 11 June 2020	(Ref: PC18010_ICm)
Panel Approval	: 23 June 2020	(Ref: 18197_PCi)
GPG Approval	: 10 July 2020	(Ref: 18197_IGt)

• **New (Apr 2020)**

1 Origin of Change:

- Other (*Specify:* Cyber Systems Panel Task no. PTPC18010)

2 Main Reason for Change:

None

3 List of non-IACS Member classification societies contributing through the TC Forum and/or participating in IACS Working Group:

None

4 History of Decisions Made:

- Ref. to Form A of Cyber Systems Panel Task no. PTPC18010 (GPG S/N 18197_).
- Development of first draft made by the Project Team, conducted via correspondence and face-to-face meetings. The team members: IRS (lead), NK, RINA.
- The draft document was developed considering the published 12 recommendations, revised taking the comments given by Joint Working Group - Cyber Systems into account and agreed by the Cyber Systems Panel through meetings and correspondences.
- The draft document was submitted to GPG for actions on 30th November 2019.
- Comments were received from GPG on 30th December 2019 and accounted for, as applicable, and revised draft was submitted on 04 February 2020.
- Resubmitted to GPG for approval on 01 April 2020.

5 Other Resolutions Changes:

The earlier published 12 recommendations from Rec 153 to 164 are to be deleted.

6 Any hinderance to MASS, including any other new technologies:

None

7 Dates:

Original Proposal	: 16 January 2017	(Ref: 16036bIGy)
Panel Approval	: 30 November 2019	(Ref: 18197_PCc)
GPG Approval	: 24 April 2020	(Ref: 18197_IGp)

Part B. Technical Background

List of Technical Background (TB) documents:

Annex 1. **TB for New (Apr 2020)**

See separate TB document in Annex 1.

Note: *There are no separate Technical Background (TB) documents for Corr.1 (July 2020) and Corr.2 (Apr 2022).*

Technical Background (TB) document for Rec. 166 (New Apr,2020)

1. Scope and objectives

Using an agreed process, harmonize and consolidate the 12 Recommendations into one single Recommendation with sufficient context and readability to be understood by all parties with responsibilities readily identified. The PT and Cyber Systems Panel interacted with Joint Working Group - Cyber Systems to:

- a) Develop Table of contents;
- b) Identify goals and sub goals (for Goal Based Standards approach);
- c) Develop functional requirements;
- d) Develop technical requirements for design and construction;
- e) Resolve applicable JWG/CS observations/comments on original 12 recommendations;
- f) Develop verification requirements;
- g) Identify documentations referred to;
- h) Identify standards and guidelines referred to; and
- i) Identify and group separately operation aspects.

2. Engineering background for technical basis and rationale

Shipboard control networks have evolved from simple stand-alone systems to integrated systems over the years and the demands for having a connectivity remote from the vessel for either for maintenance or monitoring is in increasing.

Incorporation of Ethernet technology has resulted in a growing similarity between the once disconnected fieldbus and Internet technologies. This has given rise to new terms such as industrial control networking, which encompasses not only the functions and requirements of conventional fieldbus, but also the additional functions and requirements that Ethernet-based systems present.

The network design forms the basis for reliable and robust network. Issues such as compatibility of various devices, communication between devices, communication from various systems and sub systems, need due consideration during design phase.

The network designer should have an overall holistic view of the ship network system. The network should be capable of carrying the required data in a specified time to meet the application demand. The later aspect requires detailed study of various protocols through which the system data flows.

It is observed that even when such in-depth study is carried out during design phase, there are rarely documented and reviewed by classification societies. As a result when subsequent modifications are carried out on ship systems network to meet new demands or change in technology, the original intent/design criterion is rarely considered during modifications.

Network resilience can be improved through the partition of components and thereby a reduction in the attack surface. This would limit the infection propagation and reduce the potential damage to or availability of the ship's systems.

Monitoring and alarms of critical network parameters is essential to ensure a robust system. The present recommendations also identify important tests to be carried out after installation.

The recommendation is applicable to vessel's network systems using digital communication to interconnect systems within the ship or from the ship to equipment or networks off the ship. The interconnection may be intended only for monitoring (read only) or for control or for the creation of new functionality with integrated systems.

3. Source/derivation of the proposed IACS Resolution

During the first panel meeting, the panel identified twelve subject matters that the panel should focus on and use as the basis of the roadmap developed in response to GPG request (GPG81, FUA no.14), sent on 21 October 2016 (GPG 16188, PC16007).

This recommendation on cyber resilience covers the constructional aspects of 12 published recommendations. The operational aspects have been identified from each of 12 recommendations and have been grouped under separate annexure.

The following international or industrial standards have been considered as a technical background for this recommendation.

1. IMO MSC-FAL.1/Circ.3, "Guidelines on Maritime Cyber Risk Management", July 2017
2. IACS published recommendations nos. 153 to 164

4. Summary of Changes intended for the revised Resolution:

N/A

5. Points of discussions or possible discussions

N/A

6. Attachments if any

N/A

Recommendation No. 167 “Guidelines for the Identification of Vibration Issues and Recommended Remedial Measures on Ships”

Summary

Corrigenda 1 of this recommendation is updated to correct a typographical error.

Part A. Revision History

Version no.	Approval date	Implementation date when applicable
Corr.1 (Mar 2021)	19 March 2021	-
New (Dec 2020)	02 December 2020	-

• Corr.1 (Mar 2021)

1 Origin for Change:

- Suggestion by IACS member (Hull Panel Member)

2 Main Reason for Change:

A typographical error was identified by Hull Panel Member as below.

“..... the functional requirement 3.2.1.11 in Resolution ~~MSC.286(87)~~ MSC.296(87) GBS verification guidelines”

3 List of non-IACS Member Classification Societies contributing or participating in IACS Working Group:

None

4 History of Decisions Made:

A Hull Panel Member identified a typographical error and Hull Panel Secretary (who is also PM of PT/GBS) & Accredited Representative to IMO confirmed that it should be corrected.

5 Other Resolutions Changes

None

6 Any hinderance to MASS, including any other new technologies:

None

7 Dates:

Original Proposal: 18 February 2021 (Made by: A Hull Panel Member)
 Panel Approval: -
 GPG Approval: 19 March 2021 (Ref: 19234_IGp)

- **New (Dec 2020)**

1 Origin for Change:

- Request by non-IACS entity (*IMO GBS auditor*)
- Suggestion by IACS member

2 Main Reason for Change:

During the initial GBS compliance audit of the CSR for BC&OT the GBS auditors observed that no guideline is available for surveyors on acceptable corrective measures if unacceptable vibration is observed. Therefore, IACS received an "observation" as a Finding of the GBS audit, FR1-8/OB/08 – Vibration. The summary in IACS Corrective action Plan of December 2015 was described as follows.

- Current situation:
 - Vibration is not explicitly included in the structural rules.
 - Vibration is generally considered by Surveyors during testing (sea trials).
 - Guidelines for surveyors on acceptable corrective measures for vibration are not available.
- Corrective Action
 - Undertake a study to address issues raised in the audit report
 - Consider the development of IACS Guidelines for Surveyors on acceptable corrective measures for excessive vibration when identified

3 List of non-IACS Member Classification Societies contributing or participating in IACS Working Group:

None

4 History of Decisions Made:

IACS decided to address all observations made by the GBS Audit Teams. Therefore, the Hull Panel PT PH36 team assigned to address this observation prepared a GBS Corrective Action Plan submitted to the IMO in Dec 2015, which included the development of a Guidelines for Surveyors on vibration.

PT PH36 delivered the initial proposal to Hull Panel for review in November 2017.

In November 2019 the document was sent to GPG and Survey Panel for review/consultation after review, updates and approval by EG/GBS and Hull Panel.

In April 2020 Hull Panel in consultation with Permsec was tasked by GPG to prepare a list of relevant industry associations/organizations for review of the proposed recommendation on vibration.

The document was sent for external review to organisations represented in CSR External Advisory Group (EAG) in May 2020.

Based on comments and feedback from the external review, HP Chair updated the recommendation in consultation with vibration specialists in BV and DNV GL (who were assisting the team members in PT PH36 in 2017) before final review and approval by HP in September 2020.

5 Other Resolutions Changes

None

6 Any hinderance to MASS, including any other new technologies:

None

7 Dates:

Original Proposal: November 2017 (Made by: PT PH36 and Hull Panel)

Panel Approval: 06 November 2020 (Ref: 19234_PHg)

GPG Approval: 02 December 2020 (Ref: 19234_IGn)

Part B. Technical Background

List of Technical Background (TB) documents:

Annex 1. **TB for New (Dec 2020)**

See separate TB document in Annex 1.



Note: *There are no Technical Background (TB) documents available for Corr.1 (Mar 2021).*

Technical Background document for Rec. 167 (New, Dec 2020)

1 Scope and objectives

The developed Guideline is made for the purpose of supporting/handling vibration problems on newly built or in-service vessels and lists a few common remedial actions to make improvements to address typical vibration problems. It is strongly recommended that consideration be given to employing experts in the measurement, evaluation and resolution of issues when vibration problems are present.

As a guideline, the information contained in the document is not necessarily a direct matter of class but contains information that IACS considers to be helpful as advice to the marine industry.

2 Engineering background for technical basis and rationale

No new technical or engineering aspects were developed, therefore no background information is necessary. Most of the information was compiled from existing guidance or international standards.

3 Source/derivation of the proposed IACS Resolution

During initial development the information contained in ABS document "*Guidance Notes on Ship Vibration*", January 2015 version was referenced. However only those topics of the ABS document pertaining to Surveyor guidance have been included in the IACS Guidelines.

References to ISO Standards for vibration measurements are listed in Sec. 5 of the IACS document.

4 Summary of Changes intended for the revised Resolution

None

5 Points of discussions or possible discussions

No particular discussion item was noted during the development that may arise during implementation of the Guideline.

6 Attachments if any

None

Recommendation No.168 “Stowage of timber deck cargo on ships having timber freeboards assigned (ICLL Reg.44 and 45)”

Summary

This recommendation provides additional advice on the transverse extent of the stowage of timber which should be followed when using timber load lines in accordance with regulations 44 and 45.

Part A. Revision History

Version no.	Approval date	Implementation date when applicable
New (June 2021)	08 June 2021	Not applicable

- **New (June 2021)**

This is a new recommendation based on the old UI LL35

1 Origin for Change:

Suggestion by IACS member

2 Main Reason for Change:

UI LL35 is only applicable to ICLL 1966 and the basic 1988 Protocol and not the 1988 Protocol as amended by resolutions MSC.329(90), MSC.356(92) and MSC.375(93). It used recommendatory language which is more suited to a recommendation.

3 List of non-IACS Member Classification Societies contributing or participating in IACS Working Group:

None

4 History of Decisions Made:

Based on Periodic review of IACS Resolution by Safety Panel, the Panel originally considered that the footnotes should be updated. Review by GPG commented on the recommendatory language. After further review the Safety Panel agreed that it should be converted to a recommendation.

5 Other Resolutions Changes

None

6 Any hinderance to MASS, including any other new technologies:

None

7 Dates:

Original Proposal: 31 December 2020 (Made by: Safety Panel)
Panel Approval: 21 May 2021 (Ref: PS19002pISh)
GPG Approval: 08 June 2021 (Ref: 19001ilGj)

Part B. Technical Background

List of Technical Background (TB) documents:



Note: There is no Technical Background (TB) document available for the New (June 2021).

Recommendation No. 169 “Guidelines on Approval of High Manganese Austenitic Steel for Cryogenic Service”

Summary

Guidelines has been established to apply high manganese austenitic steel for cryogenic service. High manganese austenitic steel is applicable to construction of cargo and fuel tanks complying with the IGC and IGF Codes.

Part A. Revision History

Version no.	Approval date	Implementation date when applicable
New (Sep 2021)	21 September 2021	-

• New (Sep 2021)

1 Origin of Change:

- Suggestion by IACS member

2 Main Reason for Change:

None – new document

3 List of non-IACS Member classification societies contributing or participating in IACS Working Group:

None

4 History of Decisions Made:

See technical background

5 Other Resolutions Changes:

None

6 Any hinderance to MASS, including any other new technologies:

None

7 Dates:

Original Proposal : 29 November 2020 (Made by: EG/M&W)
 EG/MW Approval : 03 September 2021 (Ref: 13202_EMWr)
 GPG Approval : 21 September 2021 (Ref: 13202_IGzzb)

Part B. Technical Background

List of Technical Background (TB) documents:

Annex 1. **TB for Original Resolution**

See separate TB document in Annex 1.



Technical Background (TB) document for Guidelines (New Sep 2021)

1. Scope and objectives

The number of shipbuilding orders for large-sized LNG carriers and LNG-fuelled ship has been increasing, owing to the growing global demand for LNG as an environment-friendly energy source.

The high manganese austenitic steel has been designed and developed for cryogenic applications, specifically including LNG cargo tanks or LNG fuel tanks. With appropriate strengthening mechanisms, cost-effective high manganese austenitic steel can combine high strength with excellent toughness at cryogenic temperature.

IACS has recognized that it is necessary to develop guidelines on approval of high manganese austenitic steel for cryogenic service.

2. Engineering background for technical basis and rationale

The following issues were highlighted that IACS needed to address:

- (1) The requirements for material specification and manufacturing process approval have been developed based on the UR W11.
- (2) Necessity evaluation for fracture toughness test such as ductile fracture toughness test.
- (3) Evaluation for the need of S-N testing and fatigue crack growth testing both at -165°C.

Two items (2) and (3) were taken into account in IACS EG/MW and in MSC/CCC.

MSC agreed to include in the 2016-2017 biennial agenda of the CCC sub-Committee and the provisional agenda for CCC 3 a new output on "Suitability of high manganese austenitic steel for cryogenic service and development of any necessary amendment to the IGC Code and IGF Code". CCC 4 head the working group and CCC sub-committee decided to re-establish the correspondence group on suitability of high manganese austenitic steel for cryogenic service. CCC 5 established "Interim Guidelines on the Application of High Manganese Austenitic Steel for Cryogenic Service"

Based on comments made during development and report from CCC, the following TB items are noted:

Section Appendix A, 3.7.3 and 3.7.4(c) : This text is related to ductile fracture toughness. Ductile fracture toughness test J_{1c} may be carried out to assess the safety issue at cryogenic service temperature. This test may be omitted at the discretion of Classification Society.

Section Appendix A 3.6.1, 3.6.2(h)/(i), 3.7.3, 3.7.4(i)/(j) : This text is related to evaluation of S-N curve and fatigue crack growth rate test. At the discretion of the Classification Society, test may be waived.

3. Source/derivation of the proposed IACS Resolution

MSC.1/Circ.1599, "INTERIM GUIDELINES ON THE APPLICATION OF HIGH MANGANESE AUSTENITIC STEEL FOR CRYOGENIC SERVICE"

MSC.1/Circ.1599/Rev.1, "REVISED INTERIM GUIDELINES ON THE APPLICATION OF HIGH MANGANESE AUSTENITIC STEEL FOR CRYOGENIC SERVICE"

ASTM A1106/A1106M-17 : Standard Specification for Pressure Vessel Plate, Alloy Steel, Austenitic High Manganese for Cryogenic Application

ISO 21635:2018, Ships and marine technology-Specification of High Manganese Austenitic Steel used for LNG tanks on board ships

4. Summary of Changes intended for the revised Resolution:

None

5. Points of discussions or possible discussions

None

6. Attachments if any

None

Recommendation No.170 "The term of "heavy load carrier" for the application of EEDI/EEXI and CII"

Summary

This recommendation shows the ships which are typically regarded as "heavy load carrier" mentioned in the definition of general cargo ship in Regulation 2.2.15 of MARPOL Annex VI and provides criterions for the Heavy Lift Multi-Purpose ships, Premium Project carriers and Project Cargo Carriers for the identification.

Part A. Revision History

Version no.	Approval date	Implementation date when applicable
New (May 2022)	05 May 2022	-

• New (May 2022)

1 Origin of Change:

- Suggestion by IACS member

2 Main Reason for Change:

None

3 List of non-IACS Member classification societies contributing or participating in IACS Working Group:

None

4 History of Decisions Made:

The Environmental Panel conducted discussions on the term "heavy load carrier" mentioned in the definition of general cargo ship in Regulation 2.2.15 of MARPOL Annex VI, and preliminarily agreed that a common understanding was necessary since members had different views on this term. The Panel reviewed various options to address the issue along with relevant analysis submitted by members. After further consideration, the Panel developed an IACS Rec to provide criterions for the identification of "heavy load carrier", taking into account current cognition on this term in the industry.

5 Other Resolutions Changes:

None

6 Any hinderance to MASS, including any other new technologies:

None

7 Dates:

Original Proposal	: 20 July 2021	(Made by: Environmental Panel)
Panel Approval	: 25 March 2022	(Ref: PE21035a)
GPG Approval	: 05 May 2022	(Ref: 22020_IGe)

Part B. Technical Background

List of Technical Background (TB) documents for Rec 170:

Annex 1. **TB for New (May 2022)**

See separate TB document in Annex 1.

Technical Background (TB) document for Rec 170 (New May 2022)

1. Scope and objectives

According to relevant regulations of EEDI / EEXI and CII and regulation 2.2.15 of MARPOL Annex VI, the heavy load carriers are waived from EEDI / EEXI and CII regulation. However, it is difficult to figure out if the general cargo ship can be waived as a heavy load carrier because "heavy load carrier" is not defined. IACS has recognized that it is necessary to develop criterions to define "heavy load carrier" to clarify the application of EEDI / EEXI and CII regulation.

2. Engineering background for technical basis and rationale

It is acknowledged that (Heavy Load) Deck Carriers, Semi-submersible Project Cargo Carriers and Deck Carriers are normally regarded as Heavy Load Carrier today already. In addition to those ships following criterions are proposed.

(1) Criterion of as used in 2020 IMO IS Code

In 2020 IMO IS Code a criterion is given, describing under which condition ships are regarded as being "engaged in lifting" as $M_L = 0.67 \times \Delta \times GM \times \left(\frac{f}{B}\right)$.

where:

M_L = threshold value for the heeling moment, in (t.m), induced by the (lifting equipment and) load in the lifting equipment

GM = the initial metacentric height, in (m), with free surface correction, including the effect of the (lifting equipment and) load in the lifting equipment

f = the minimum freeboard, in (m), measured from the upper side of the weather deck to the waterline

B = the moulded breadth of the ship, in (m)

Δ = the displacement of the ship, including the lift load, in (t)

For "heavy load carrier", the threshold value for the heeling moment, as compared with "ships engaged in lifting", is increased with a factor of "2" and introduced on the right side of the formula. As heeling moment, the crane moment of the two largest cranes operating in tandem lift mode is assumed as $M_L = 2 \times SWL \times Outreach\ crane$

- SWL = maximum safe working load of crane of crane of one single crane

- Outreach crane = outreach from turning axis of crane

moreover:

Δ = Displacement of vessel at freeboard draft T

GM = 1.0m

f = D-T (Freeboard = Depth - freeboard draft)

B is the moulded breadth of the vessel measured amidships at draft T

Then:

Original: $M_L\ in\ tandem\ mode \geq 2 \times 0.67 \times \Delta \times GM \times \left(\frac{f}{B}\right)$

Modified: $2 \times SWL \times outreach \geq 2 \times 0.67 \times Displacement@T \times 1.0 \times \left(\frac{D-T}{B}\right)$

Final: $SWL \times outreach \geq 0.67 \times Displacement@T \times \left(\frac{D-T}{B}\right)$

(2) Project Cargo Carriers

The Administration might make their decision on a design-specific application to be compiled by the Owner/Company, submitted through RO, where it is lined out, which criteria of a Project Cargo Carrier are implemented on the subject design, which justify

the vessel to be considered as "heavy load carrier". This proposal represents a solution for non-geared Project Cargo Carrier type of ships. The proposal was regarded as a fair compromise, as no objective criteria could be found.

2a. Specification of the data utilised in the development/revision of the proposed IACS Resolution, if any

None.

3. Source/derivation of the proposed IACS Resolution

Following standards and IMO Documents are quoted.

International Code on Intact Stability (IS CODE) Edition 2020

4. Summary of Changes intended for the revised Resolution:

None

5. Points of discussions or possible discussions

Other than the recommendation, the following candidates are considered, although these were not employed at this stage.

(1) DWT / GT ratio

Due to the special design features of "heavy load carrier", it is assumed that the feature a reduced DWT in relation to their GT in comparison with an "ordinary" General Cargo ship of similar size/ GT.

However, an analysis of the General Cargo fleet based on IHSF data did not give any evidence that the DWT/ GT ratio is a useful criterion to identify typical vessels, which should be regarded as HLCs.

(2) DWT/ GT ratio as proposed in Dutch flag IMO submission

MEPC 76/INF.41(Netherlands) shows a criteria to identify smaller vessels, which are suggested to be exempted from CII because of their special characteristics, making them "outliers". The proposal addresses among others General Cargo vessels, which are fitted with cargo gears, are designed for at higher speeds and have a lower DWT/ GT ratio. Relevant vessels should have $DWT/GT \leq 0,00002 \times DWT + 1,15$.

However, it is not clear, why vessel size has been limited to 20.000 dwt-there are also larger vessels with heavy cargo gear. Also, it seems that too many vessels would be exempted by applying this criteria.

(3) SWL Capacity of largest crane

It was suggested to use the capacity (SWL) of the single largest crane as a criterion, whether a ship could be considered as Heavy Load Carrier.

However, the impact of the crane SWL on the ship design is obviously depending on vessel's size. It is a big difference to install a crane with a capacity of say 250 t on a 8.000 dwt ship, compared with installing the same crane on a 30.000 dwt ship. This appears to be too simplistic and the threshold value might be questioned.

(4) Crane moment

It was suggested to use the crane moment (SWL × Outreach) of the single largest crane as a criterion, whether a ship could be considered as Heavy Load Carrier.

However, this appears to be too simplistic and the threshold value might be questioned.

(5) Crane moment/ DWT ratio

It was suggested to use the ratio between crane moment (SWL × Outreach) of the single largest crane divided by the vessels' deadweight as a criterion to decide, whether a ship could be considered as Heavy Load Carrier.

The impact of such approach is somewhat difficult to judge, as the parameter "Crane outreach" is not given in the IHSF database. This appears to be too simplistic and the threshold value might be questioned.

(6) Class notation "Strengthened" (or "Heavy cargo" or similar)

Reinforced inner bottom and/or deck/ hatch covers demonstrate a vessel's capability to carry heavy cargo, which is typically expressed by a corresponding class notation.

—
In principle, this is a valid consideration, however such class notation is quite commonly assigned, not only to General Cargo Ships but also to Bulk Carriers and other ship types. There are many "ordinary" General Cargo vessels, which have reinforced inner bottom or deck, which hardly carry any heavy and or oversized cargo. It is estimated that more than 3.000 General Cargo Ships feature such class notation-it would be hard to justify that so many vessels should be exempted from EEDI/ EEXI/ CII by defining them as "heavy load carrier". The EEDI framework offers a correction factor to compensate for "voluntary structural enhancements" (like "Strengthened") already, even though this correction factor is difficult to apply for existing vessels. There are too many options/ no clear requirement, which areas and how much reinforcement should be applied to qualify to be regarded as "heavy load carrier".

In addition, there may be some concerns in the future regarding the single criterion as stated in paragraph 3.2.1 of the REC. One might opine that heavy Lift vessels are vessels engaged in heavy lift operations while the main feature and ability that determines a heavy load carrier is its ability to carry "heavy and voluminous cargo" and can even be without lifting gear. Applying a single technical criterion and threshold the lifting capacity based on heavy lift type to determine and define Heavy Load Carrier may not be consistent or substantially justified. However, it should be noted that lifting ability is normally regarded as a significant feature of Premium Project carriers, and can be used to distinguish them from the Project Cargo Carriers by the industry. The Panel discussed and evaluated various options and develop this REC, and would be open for further consideration on any possible additional criterion that could be included in the REC.

6. Attachments if any

None

Recommendation No.171 “Recommendation on incorporating cyber risk management into Safety Management Systems”

Summary

This Recommendation has been developed with a view to addressing of cyber safety issues within the context of MSC-FAL.1-Circ.3, Guidelines on Maritime Cyber Risk Management. The document aims to:

1. Develop a guideline on incorporating cyber risk into ISM, in order to help ship-owners on how to do risk assessment for cyber system and on what should be done for mitigation of the risks.
2. Provide a common framework to carry out risk assessment based on which risk mitigation measures are implemented.

Part A. Revision History

Version no.	Approval date	Implementation date when applicable
New (May 2022)	27 May 2022	-

• New (May 2022)

1 Origin of Change:

- Suggestion by IACS member

2 Main Reason for Change: None

3 List of non-IACS Member classification societies contributing or participating in IACS Working Group: None

4 History of Decisions Made:

Oct 2021: 141 comments have been received from Class Societies DNV, ABS, NK, PRS, CCS, IRS, CRS, KR, LR and RS:

- Recommendation must be expressed in broad terms in order to have a widespread application.
- Develop several paragraphs of guidance and explanation in order to explain the purpose, the significance and how the Recommendation should be implemented.
- Move some tables to related appendixes to make this document clearer.
- Replace “Score” by “Grade” in the whole draft.
- Address effects of mitigation measures.

Dec 2021: 68 comments have been received from Class Societies DNV, ABS, NK, PRS, CCS, IRS, CRS, KR and RS:

- Insist on the fact that this Recommendation is not intended to standardize risk assessment methods, but just to provide examples that can be used as reference when relevant parties consider them.
- Add list of standard references for cyber security risk analysis.
- Insist on the fact that impact grades in this Recommendation are propositions, and not mandatory grades.
- Amend multiple lines in the list of systems to be addressed.

Jan 2022: 21 comments have been received and addressed from Class Societies RS, RINA, DNV and ABS.

Feb 2022: 42 comments have been received and addressed from JWG (EG/MS, CIRM, BIMCO, INTERCARGO) and Class Society NK:

- Change title recommendation from “cyber risk into ISM” to “cyber management risk into Safety Management Systems”, which is consistent with the current contents of the recommendation, that is not only addressing cyber security risk analysis, but cyber risk management as well.
- Introduce IACS Recommendation REC 127 among references likely to be used.
- Amend risk matrixes design.
- Insist on the fact that cyber security risk analysis is a heavy task.

5 Other Resolutions Changes: None

6 Any hinderance to MASS, including any other new technologies: None

7 Dates:

Original Proposal	: 21 January 2021	(Ref: 20178_PCa, made by CS Panel)
Panel Approval	: 03 February 2022	(Ref: PC20006_ICq)
GPG Approval	: 27 May 2022	(Ref: 20178_IGi)

Part B. Technical Background

List of Technical Background (TB) documents for Rec 171:

Annex 1. **TB for New (May 2022)**

See separate TB document in Annex 1.

Technical Background (TB) document for Rec 171 (New May 2022)

1. Scope and objectives

IMO having decided that cyber security shall be handled in accordance with the existing objectives and functional requirements of the ISM Code. Companies (DOC holders) should use their existing Safety Management Systems (and SMS measures) to assess risks and implement safeguards and otherwise handle cyber security. The goal of this Recommendation is to facilitate cyber security risk assessment and cyber security risk management for readers.

It is important for them to utilize the opportunity to strengthen the overview of IT and OT critical systems on board and to use risk assessments to implement appropriate safeguards and implement measures likely to lower risk to an acceptable level.

2. Engineering background for technical basis and rationale

The proposed risk assessment methodology uses the following principles:

- Threats on critical systems are studied by relying on the consequences, should the threat occur, for confidentiality, integrity, availability and traceability of information considering that, when operational and/or information technology vulnerabilities are exploited on critical systems (e.g. bridge navigation or main propulsion systems), there can be implications for the safe operation of the ship and/or protection of the environment.
- Cyber incidents are studied for their impact on the vessel safety and on the continuity of operational activities.
- Impact and Likelihood determine a Risk Level, which will be referred to for possible mitigation measures.

Appendixes help readers defining cyber security risk mitigation measures, provide recommendations on Cyber Security Training and Awareness (as cyber security training and awareness is a common but powerful risk mitigation measure), and provide as well topics that should be considered when developing the procedures to be inserted into Safety Management Systems.

3. Source/derivation of the proposed IACS Recommendation None

4. Summary of Changes intended for the revised Resolution None

5. Points of discussions or possible discussions None

6. Attachments None

Recommendation No.172 “EEXI Implementation Guidelines”

Summary

IACS identified ambiguities relating to IMO guidelines supporting EEXI framework, and developed this recommendation for supporting the implementation of IMO EEXI framework.

Part A. Revision History

Version no.	Approval date	Implementation date when applicable
Rev.1 (Apr 2024)	26 April 2024	-
New	15 June 2022	-

- **Rev.1 (Apr 2024)**

1 Origin of Change:

- Other (*Specify: This new revision is the outcome of the panel's work during the upgrading to PR, a process that has ultimately been abandoned*)

2 Main Reason for Change:

After the publication of the new Rec. 172, one Member suggested upgrading Rec. 172 to a new PR. The proposal was agreed by GPG and the Environmental Panel was tasked to upgrade Rec. 172 to a new PR.

After consideration of the initial draft of the new PR submitted by Environmental Panel, GPG agreed to task EP to continue with a thorough review of the initial draft of the new PR to resolve all pending technical issues and auditability review comments from QC in the process.

The Environmental Panel considered how to continue with a thorough review and agreed that an informal group would be established for new section 4.10 only and the other issues would be discussed at the Panel level.

During the 20th EP meeting, the panel unanimously agreed (except for IRS, who was not present) that converting Rec.172 into a PR was not advisable. Consequently, the panel unanimously resolved to request GPG to reconsider this decision. The request to reassess the necessity of this conversion, along with the reasons for the request, was communicated in document 21125dPEe on the 20 March 2024 to the GPG Chair.

Following consultations, GPG reached a decision to keep this resolution at a recommended level on the 4 April 2024 (21125dIGm). Consequently, a new revision has been issued, encompassing all the enhancements concluded by the panel during discussions for the conversion.

3 Surveyability review of UR and Auditability review of PR

None

4 List of non-IACS Member classification societies contributing or participating in IACS Working Group:

None

5 History of Decisions Made:

The key improvements in the enhanced revision include:

- A deeply revised Chapter 7, which is dedicated to the complex case of LNG carriers. The modifications effectively address and clarify key points (boil-off considerations, inclusion of DF conventional propulsion case...) significantly enhancing the chapter.
- Addition of a new Annex (which is the outcome of an informal working group) "Guidelines on the assessment of Lower Friction Hull Coatings for the purpose of deriving the Vref in the framework of the EEXI Regulation based on re-evaluation of model tests". The introduction of this new Annex has prompted the addition of a new paragraph, 4.11, aimed at delineating the scope of application of the annex.

Other significant improvements agreed by the panel:

- The introduction part now includes further clarification on the scope of application.
- The case of multiple loadlines has been also deeply modified in order to align with MEPC.364(79) (EEDI).
- The ship types also now address the case of cement carriers.
- Enhancements have been implemented in SFC (Specific Fuel Consumption) and Fuel Conversion Factor considerations, refining their accuracy.
- In addition, all relevant MEPC references have been updated to reflect the recent adoptions subsequent to MEPC 80 and 81 as well as some other editorial modifications to enhance clarity.

The panel was unable to reach a consensus on the following points:

- Whether limitations based on electronic means, especially when engine control settings are password protected without provision for crew modification, could be deemed permanent.
- Whether there are instances where engine limitations by mechanical means (such as a seal with a QR code) could be considered permanent limitations.

- The rationale behind requesting an annual survey for the seal is brought into question when considering that the IEEC is a one-time certification not subject to surveys.

In light of the lack of consensus reached on the above points, it was decided to maintain Chapter 6 in its original form, preserving the existing content and structure without alterations or updates other than the ones fully agreed by the panel.

To attain these advancements, the panel conducted a thorough examination of the recommendation. Each chapter underwent a detailed examination, with multiple rounds of discussions dedicated to each. The subject also held significant importance during the 19th and 20th EP meetings, with two dedicated sessions focused specifically on it. Furthermore, to complement these efforts, an informal group was convened to develop the new annex titled "Guidelines on the assessment of Lower Friction Hull Coatings for the purpose of deriving the Vref in the framework of the EEXI Regulation based on re-evaluation of model tests."

6 Other Resolutions Changes:

None

7 Any hinderance to MASS, including any other new technologies:

None

8 Dates:

Original Proposal	: December 2024	(Made by: Environmental Panel)
Panel Approval	: 20 March 2024	(Ref: PE24008cIEb)
GPG Approval	: 26 April 2024	(Ref: 21125dIGo)

• New (June 2022)

1 Origin of Change:

- Other - Environmental Panel Task no. PT PE04/2021(PE21038)

2 Main Reason for Change:

Not applicable, new document

3 List of non-IACS Member classification societies contributing or participating in IACS Working Group:

None

4 History of Decisions Made:

After the adoption of the EEXI framework and relevant technical guidelines at MPEC76, Environmental Panel received several queries regarding the implementation

of the EEXI requirements. After consideration, Environmental Panel recognized the existence of ambiguities that need to be further considered and GPG agreed to establish PT PE 04 to address the implementation issues associated with EEXI and develop an IACS REC containing EEXI implementation guidelines.

During the task, the draft IACS EEXI implementation guidelines was disseminated by IACS Permsec to the industry partners to obtain their feedback. In the meantime, the draft was submitted to MEPC 78 to communicate the IACS guidelines. All the feedback was fully discussed and considered by PT PE04 and reflected in the IACS guidelines as necessary.

Environmental Panel conducted a final review of the revised draft submitted by PT PE 04 and finally agree on the final draft.

5 Other Resolutions Changes:

None

6 Any hinderance to MASS, including any other new technologies:

None

7 Dates:

Original Proposal	: Date: 20 July 2021	Made by: Environmental Panel
Panel Approval	: Date: 24 May 2022	(Ref:PE21038)
GPG Approval	: Date: 15 June 2022	(Ref: 21125_IGp)

Part B. Technical Background

List of Technical Background (TB) documents for Recommendation No.172:

Annex 1. **TB for New (June 2022)**

See separate TB document in Annex 1.

Annex 2. **TB for Rev.1 (Apr 2024)**

See separate TB document in Annex 2.

Technical Background (TB) document for Rec 172 (New June 2022)

1. Scope and objectives

These implementation guidelines have been developed by IACS in response to the Resolutions MEPC.333 (76), MEPC.334 (76) and MEPC.335 (76) relating to EEXI. The document may be updated whenever new issues are brought to the attention of IACS.

2. Engineering background for technical basis and rationale

Implementation guidelines have been developed on issues which in the opinion of IACS members required clarity and transparency to achieve consistency in the application. These issues are categorized as follows:

- Capacity
- Ship Type
- EEXI Technical File
- Ship speed Vref
- SFC considerations
- Power limitation
- LNG Carriers

The development of the IACS recommendation is based on implementation experiences of members' approval/verification service, information and feedbacks from the industry regarding the implementation of the EEXI requirements.

2a. Specification of the data utilised in the development/revision of the proposed IACS Resolution, if any

Not applicable

3. Source/derivation of the proposed IACS Resolution

Resolutions MEPC.333 (76), MEPC.334 (76) and MEPC.335 (76) and industry feedback.

4. Summary of Changes intended for the revised Resolution:

Not applicable at this stage.

5. Points of discussions or possible discussions

See section 2 above. If the industry raises an issue, which has not been addressed, then this will need to be discussed.

6. Attachments if any

None.

Technical Background (TB) document for Rec 172 (Rev.1 Apr 2024)

1. Scope and objectives

The objective of these Guidelines for the Energy Efficiency Existing Index (EEXI) implementation is to provide guidance for applying attained EEXI requirements and to assist the verifier in their role of conducting surveys and certifications in accordance with the following IMO Resolution:

- MEPC.350(78) "2022 Guidelines on the method of calculation of the attained energy efficiency existing ship index (EEXI)".
- MEPC.351(78) "2022 Guidelines on survey and certification of the attained energy efficiency existing ship index (EEXI)".
- MEPC.335(76) "2021 Guidelines on the shaft/engine power limitation system to comply with the EEXI requirements and use of a power reserve" as amended by MEPC.375(80) and MEPC.390(81)

These guidelines apply to all cases of Class Societies' participation in conducting the survey, and certifying EEXI in accordance with regulations 5, 6, 7, 8 and 9 of MARPOL Annex VI, particularly in cases where EEXI Technical File is submitted.

The primary objective of the revised version is to comprehensively address all instances wherein challenges have arisen or additional clarity is deemed necessary. This revision is undertaken with the aim of fostering a unified and harmonized implementation across all members.

2. Engineering background for technical basis and rationale

Following the initial feedback on the application of the EEXI requirements, several issues have surfaced, prompting a need for further examination. The latest revision of the recommendation aims to leverage the implementation experiences of members regarding the application of the EEXI requirements, in order to efficiently address these issues while ensuring an harmonized implementation among the members.

2a. Specification of the data utilised in the development/revision of the proposed IACS Resolution, if any

None

3. Source/derivation of the proposed IACS Resolution

- MEPC.350(78) "2022 Guidelines on the method of calculation of the attained energy efficiency existing ship index (EEXI)".
- MEPC.351(78) "2022 Guidelines on survey and certification of the attained energy efficiency existing ship index (EEXI)".
- MEPC.335(76) "2021 Guidelines on the shaft/engine power limitation system to comply with the EEXI requirements and use of a power reserve" as amended by MEPC.375(80) and MEPC.390(81)

4. Summary of Changes intended for the revised Resolution:

The main changes intended for the revised recommendation is to enhance and complete the original text to effectively tackle all challenges encountered and provide any necessary

clarification, leveraging the member's experience. This revision is driven by the goal of promoting a unified and harmonized implementation among all participating members.

5. Points of discussions or possible discussions

The Introduction part of Chapter 6: as mentioned in the HF, the requirements to define some limitations as non-overridable are subject to different interpretations among the members.

Definition of tamper-proof: Considering that one of the prerequisites for overrideable limitations based on electronic means is the requirement for tamper-proof systems, it's important to note that the definition of "tamper-proof" varies among members.

At present, given the absence of sufficient experience, no immediate actions can be pursued. Nonetheless, as expertise is acquired over time, it may be opportune to reconsider and potentially revise these two aspects in the future.

In addition, considering the ongoing implementation phase of EEXI, it is foreseeable that additional issues may come to light as the process progresses and practical insights are gained.

6. Attachments if any

None

Recommendation No.173

“Guidelines on Numerical Calculations for the purpose of deriving the V_{ref} in the framework of the EEXI Regulation”

Summary

IACS developed the EEXI V_{ref} Numerical Calculation Guidelines containing a set of requirements for numerical calculations to be used for the purposes of deriving the V_{ref} in the framework of the EEXI Guidelines.

Part A. Revision History

Version no.	Approval date	Implementation date when applicable
New (Nov 2022)	16 November 2022	-

- **New (Nov 2022)**

1 Origin of Change:

- Other - Environmental Panel Task no. PT PE03/2021(PE21020)

2 Main Reason for Change:

None

3 List of non-IACS Member classification societies contributing or participating in IACS Working Group:

None

4 History of Decisions Made:

At MEPC 76, the amendments to the EEXI guidelines proposed by IACS regarding the use of Numerical Calculations for the purpose of deriving the V_{ref} as equivalent or complementary to model tests and/or sea trials were approved. After the meeting, PT PE 03 was agreed to be established to develop IACS REC with a view to providing further guidance for performing and validating numerical calculations of the EEXI reference speed V_{ref} .

During the task, the draft IACS EEXI V_{ref} Numerical Calculation Guidelines was forwarded to the other professional organization (ITTC) for seeking its advice. The draft was submitted to MEPC 78 to communicate the IACS guidelines as well. All the feedback was fully discussed and considered by PT PE03 and reflected in the IACS guidelines as necessary and the draft was submitted to the Panel for review. The

Panel considered and concluded on those key issues, e.g full-scale simulations, Benchmark studies for this task at this time, and the option for a set of comparable vessels.

Environmental Panel conducted a final review of the revised draft submitted by PT PE 03 and agree with the proposal by PT PE 03 to keep consistency with the outcome of PT PE 04, i.e REC 172 containing the IACS EEXI implementation guidelines. Finally, the Panel agreed on the final draft guidelines.

5 Other Resolutions Changes:

None

6 Any hinderance to MASS, including any other new technologies:

None

7 Dates:

Original Proposal	: 02 February 2022	(Made by: IACS PT PE03)
Panel Approval	: 10 August 2022	(Ref: PE21020)
GPG Approval	: 16 November 2022	(Ref: 21079_IGm)

Part B. Technical Background

List of Technical Background (TB) documents for Rec 173:

Annex 1. **TB for New (Nov 2022)**

See separate TB document in Annex 1.

Technical Background (TB) document for Rec 173 (New Nov 2022)

1. Scope and objectives

These implementation guidelines have been developed by IACS in response to the Resolutions MEPC.333 (76) and MEPC.334 (76) relating to EEXI. These resolutions make reference to the use of numerical calculation as a potential mean to derive the reference speed (V_{ref}). The project team was set and developed these guidelines which aim at providing guidance on the level of requirements for these numerical calculations.

The document may be updated whenever new issues are brought to the attention of IACS.

2. Engineering background for technical basis and rationale

Implementation guidelines have been developed based on the set of available texts and referenced available industry guidelines (ITTC). The group considered among others:

- Need to define terms reference in the resolutions
- Set the numerical calculations methodologies for the purposes of deriving the reference speed in accordance with the IMO resolutions
- Technical aspects relating to: scale, degrees of freedom, turbulence model, time discretization, etc.
- Reporting requirements
- Consideration of energy efficiency technologies
- Propeller open water calculations

The development of the IACS recommendation is based on information and feedbacks from the industry regarding, namely ITTC.

3. Source/derivation of the proposed IACS Resolution

Resolutions MEPC.333 (76), MEPC.334 (76) and industry feedback.

4. Summary of Changes intended for the revised Resolution:

None

5. Points of discussions or possible discussions

See section 2 above. If the industry raises an issue, which has not been addressed, then this will need to be discussed.

6. Attachments if any

None

Recommendation No.174

“Recommended procedure for the finite element analysis to assess yielding, buckling and fatigue strength of IGC Code type C tanks”

Summary

This recommendation provides general information and details when it is intended to carry out the finite element analysis of single-cylinder and multi-lobe shape IGC Code type C tanks.

Part A. Revision History

Version no.	Approval date	Implementation date when applicable
New (July 2023)	12 July 2023	-

- **New (July 2023)**

1 Origin of Change:

- Suggestion by IACS member

2 Main Reason for Change:

None.

3 List of non-IACS Member classification societies contributing or participating in IACS Working Group:

None.

4 History of Decisions Made:

Reference is made to Form A of Hull Panel Task no. PT PH47/2020 (PH20010). The recommendation document was developed by the project team PT PH47 to disseminate the details of recommended practices for the finite element analysis of IGC type C tanks, in addition to the new Unified Interpretation.

5 Other Resolutions Changes:

None.

6 Any hinderance to MASS, including any other new technologies:

None.

7 Dates:

Original Proposal	: 31 August 2022	(Made by: PT-PH47)
Panel Approval	: 23 June 2023	(Ref: PH20010dIHi)
GPG Approval	: 12 July 2023	(Ref: 20152aIGb)

Part B. Technical Background

List of Technical Background (TB) documents for Recommendation No.174:

Annex 1. **TB for New (July 2023)**

See separate TB document in Annex 1

Technical Background (TB) document for Rec 174 (New July 2023)

1. Scope and objectives

The IGC Code addresses the principles for the design analyses which are carried out to verify the structural integrity of type C tanks. However, the Code makes no mention of detailed methodology or recommended practices for the finite element(FE) analysis concerning yielding, buckling and fatigue strength assessment.

This recommendation aims to provide general information and details for the finite element analysis of single-cylinder and multi-lobe shape IGC Code type C tanks. Additionally well-established international codes for design by analysis may be referenced as required. e.g., ASME Sec VIII Div. 2.

2. Engineering background for technical basis and rationale

The recommended procedural details are based on recognized standards, many past engineering practices and established requirements of Classification Societies which are considered to be specifically applicable to the finite element analysis of IGC Code type C tanks including the technical requirements of FE modelling including mesh size, boundary conditions, design loads including load cases and load combinations, acceptance criteria in the strength regarding plastic deformation, the procedure including modelling, initial imperfection, load-displacement curve for assessment in the buckling strength assessment by non-linear finite element analysis, as well as the critical locations, modelling, design loads, stress calculation, S-N curve and acceptance criteria in fatigue strength assessment.

The case studies have been carried out and the results demonstrate that the technical requirements specified in the Rec.174 are appropriate and available for the FE application.

3. Source/derivation of the proposed IACS Resolution

Reference was made to:

- IMO Resolution MSC.370(93) Amendments to the international code for the construction and equipment of ships carrying liquefied gases in bulk (IGC Code), 2014
- ASME Boiler and Pressure Vessel Code, section 8, division 2, Alternative Rules, 2021
- BSI PD5500, Specification for unfired pressure vessels, 2021
- BSI BS7608, Guide to fatigue design and assessment of steel product, 2014

4. Summary of Changes intended for the revised Resolution:

None.

5. Points of discussion or possible discussions

None.

6. Attachments if any

Attachment 1: Case study/consequence assessment for yielding strength analysis

Attachment 2: Case study for non-linear analysis

Attachment 3: Case study for fatigue assessment

Attachment 1

Case study/consequence assessment for yielding strength analysis

1. Case 1: bi-lobe type C LNG tank

1.1 Modelling

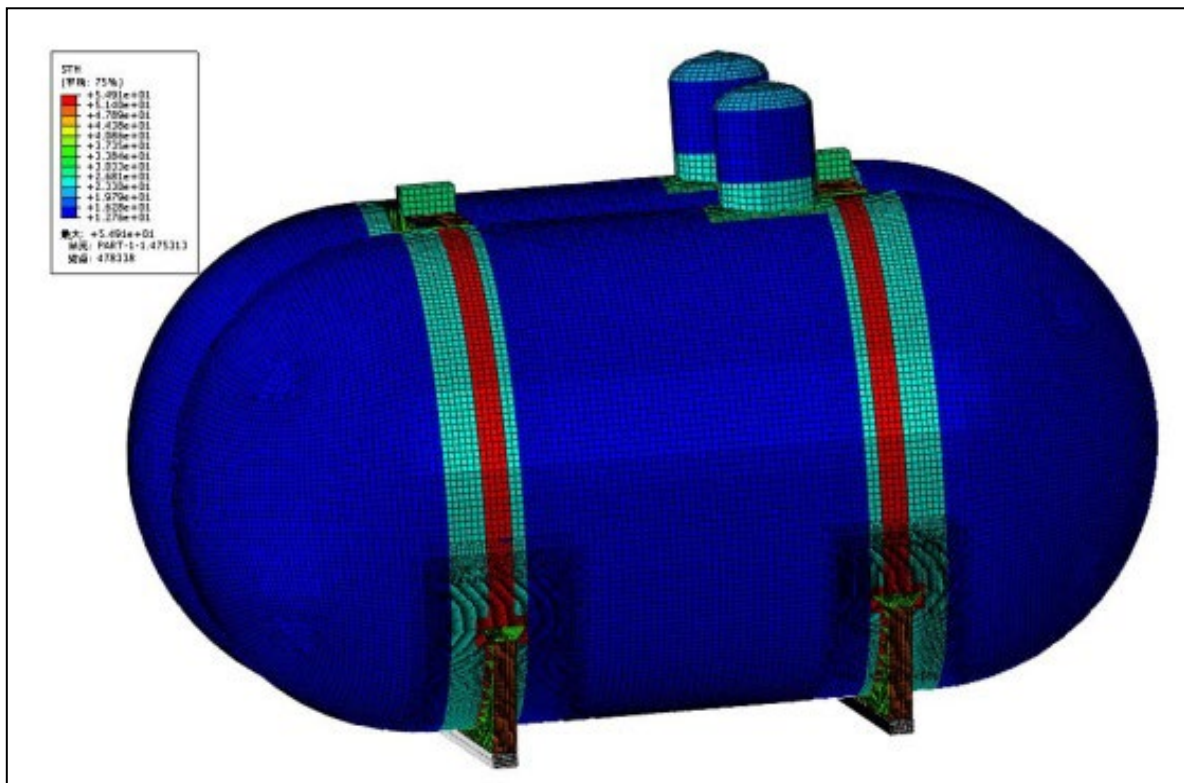

Figure 1 Finite element model of bi-lobe type C LNG tank

1.1.1 Mesh size and element type

8-node shell elements are used for tank body. Mesh sizes are as follows.

- Location[A]: Areas without structural discontinuities: 200mm×200mm
- Location[B]: Area in way of structural discontinuities: 50mm×50mm ~ t x t

Solid elements are used for press-wood.

1.1.2 Boundary conditions

Contact condition for the surface between press wood and tank support is applied. Details of the boundary conditions are shown in Figure 2.

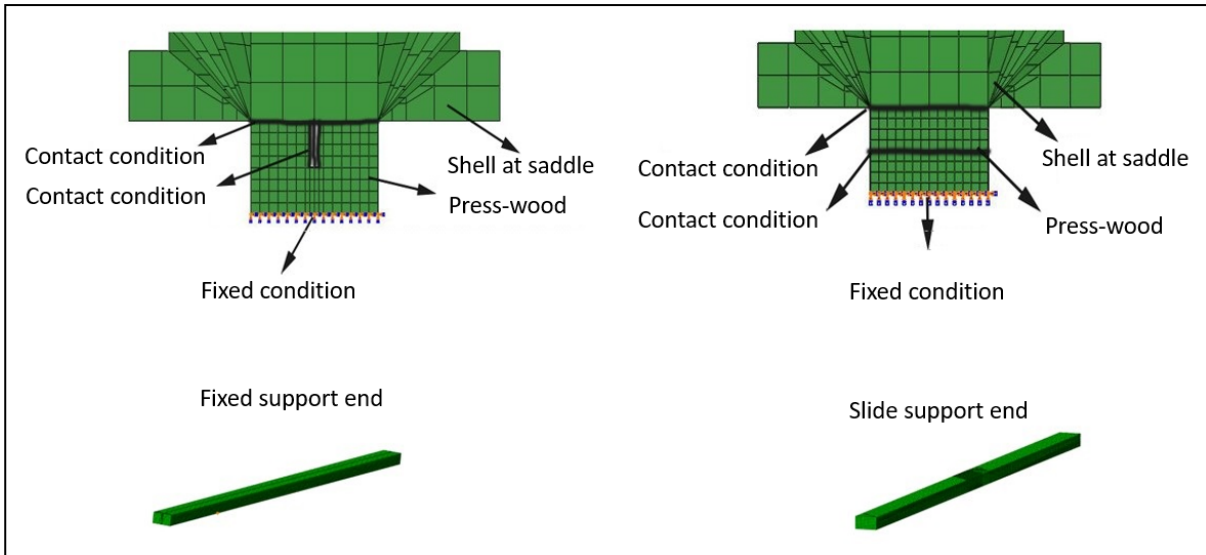

Figure 2 Boundary conditions for contact surfaces

1.2 Applied loads

1.2.1 Load cases

Dynamic, static heel, collision and tank test load cases the relevant load combinations are applied according to the tables defined in Recommendation No.174. The internal pressure, P_{eq} , at load calculation point i is calculated in accordance with IGC code.

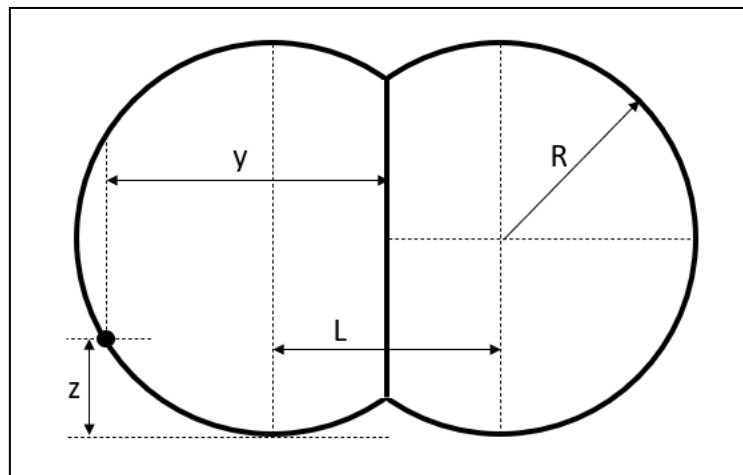

Figure 3 Diagram for internal pressure calculation

$$P_{eq1} = P_o + (P_{gd})_{max} \text{ (MPa)}$$

$$P_{gd,i} = \frac{a_y^2 \cos \beta_i + a_y a_z \sqrt{(a_y \cos \beta_i)^2 + (a_z \sin \beta_i)^2 - (\sin \beta_i)^2}}{(a_y \cos \beta_i)^2 + (a_z \sin \beta_i)^2} \cdot \left[R + (R - z) \cos \beta_i + \left(\frac{L}{2} - y \right) \sin \beta_i \right] \frac{\rho}{1.02 \times 10^5} \text{ (MPa)}$$

Where,

$$P_0 = 0.35 \text{ MPa}$$

$$\rho = 0.5 \text{ t/m}^3$$

1.2.2 Loads applied on FE model

LC ID	LC Name	Load	Rotate / heel angle	The factor of acceleration of motion or weight	Resultant acceleration
LC01	LD, CL1, CL2	Inertia forces of the tank	0°	(0.5,0,-1) g	1.12 g
LC02	TD	"	0°	(0,0.64,-1) g	1.19 g
LC03	VD	"	0°	(0,0,-1.54) g	1.54 g
LC04	SH1	"	30°	(0,0,-1) g	1.0 g
LC05	TT1	"	0°	(0,0,-1) g	1.0 g
LC06		Weight + thermal	0°	(0,0,-1) g	1.0 g

(*Note: The flooding condition was not included in this case study)

1.2.3 Temperature application

Following temperatures are applied for all load cases except testing condition.

- Tanker inner part: -163°C
- Atmosphere: +20°C

1.3 Stress results

1.3.1 Von-Mises membrane stresses

Item	LC ID	Stress category	Calculated stress (MPa)	Allowable stress (MPa)	Result evaluation
Tank body	LC01	σ_m	160	213 (1.0 f)	Pass
	LC02	σ_m	161	213 (1.0 f)	Pass
	LC03	σ_m	167	213 (1.0 f)	Pass
	LC04	σ_m	159	213 (1.0 f)	Pass
	LC05	σ_m	223	387 (0.9 Re)	Pass
Y-connection	LC01	σ_L	202	320 (1.5 f)	Pass
	LC02	σ_L	222	320 (1.5 f)	Pass
	LC03	σ_L	260	320 (1.5 f)	Pass
	LC04	σ_L	203	320 (1.5 f)	Pass
	LC05	σ_L	243	387 (0.9 Re)	Pass
Heavy stiffening rings	LC01	σ_L	80	320 (1.5 f)	Pass
	LC02	σ_L	91	320 (1.5 f)	Pass
	LC03	σ_L	122	320 (1.5 f)	Pass
	LC04	σ_L	77	320 (1.5 f)	Pass
	LC05	σ_L	248	387 (0.9 Re)	Pass

Item	LC ID	Stress category	Calculated stress (MPa)	Allowable stress (MPa)	Result evaluation
Longitudinal bulkhead	LC01	σ_L	138	320 (1.5 f)	Pass
	LC02	σ_L	137	320 (1.5 f)	Pass
	LC03	σ_L	139	320 (1.5 f)	Pass
	LC04	σ_L	137	320 (1.5 f)	Pass
	LC05	σ_L	205	387 (0.9 Re)	Pass

1.3.2 Von-Mises surface stresses

Item	LC ID	Stress category	Calculated stress (MPa)	Allowable stress (MPa)	Result evaluation
Tank body	LC01	$\sigma_m + \sigma_b + \sigma_T$	162	639 (3.0 f)	Pass
	LC02	$\sigma_m + \sigma_b + \sigma_T$	163	639 (3.0 f)	Pass
	LC03	$\sigma_m + \sigma_b + \sigma_T$	169	639 (3.0 f)	Pass
	LC04	$\sigma_m + \sigma_b + \sigma_T$	160	639 (3.0 f)	Pass
	LC05	N/A	N/A	N/A	N/A
Y-connection	LC01	$\sigma_m + \sigma_b + \sigma_T$	353	639 (3.0 f)	Pass
	LC02	$\sigma_m + \sigma_b + \sigma_T$	367	639 (3.0 f)	Pass
	LC03	$\sigma_m + \sigma_b + \sigma_T$	392	639 (3.0 f)	Pass
	LC04	$\sigma_m + \sigma_b + \sigma_T$	349	639 (3.0 f)	Pass
	LC05	N/A	N/A	N/A	N/A
Heavy stiffening rings	LC01	$\sigma_m + \sigma_b + \sigma_T$	80	639 (3.0 f)	Pass
	LC02	$\sigma_m + \sigma_b + \sigma_T$	92	639 (3.0 f)	Pass
	LC03	$\sigma_m + \sigma_b + \sigma_T$	154	639 (3.0 f)	Pass
	LC04	$\sigma_m + \sigma_b + \sigma_T$	78	639 (3.0 f)	Pass
	LC05	N/A	N/A	N/A	N/A

Item	LC ID	Stress category	Calculated stress (MPa)	Allowable stress (MPa)	Result evaluation
Longitudinal bulkhead	LC01	$\sigma_m + \sigma_b + \sigma_T$	137	639 (3.0 f)	Pass
	LC02	$\sigma_m + \sigma_b + \sigma_T$	138	639 (3.0 f)	Pass
	LC03	$\sigma_m + \sigma_b + \sigma_T$	138	639 (3.0 f)	Pass
	LC04	$\sigma_m + \sigma_b + \sigma_T$	136	639 (3.0 f)	Pass
	LC05	N/A	N/A	N/A	N/A

1.3.3 Summary of stress results

Load case	Tank body		Y-connection		Heavy stiffening ring		Longitudinal bulkhead	
	Mem.	Sur.	Mem.	Sur.	Mem.	Sur.	Mem.	Sur.
LC01	160	162	202	353	80	80	138	137
LC02	161	163	222	367	91	92	137	138
LC03	167	169	260	392	122	154	139	138

LC04	164	160	203	349	77	78	137	136
LC05	159	N/A	243	N/A	248	N/A	205	N/A
Max. stress	167	169	260	392	248	154	205	138
Max. LC	LC05	LC03	LC03	LC03	LC05	LC03	LC05	LC03

1.4 Stress contour (LC03 load case)

1.4.1 Area away from structural discontinuities

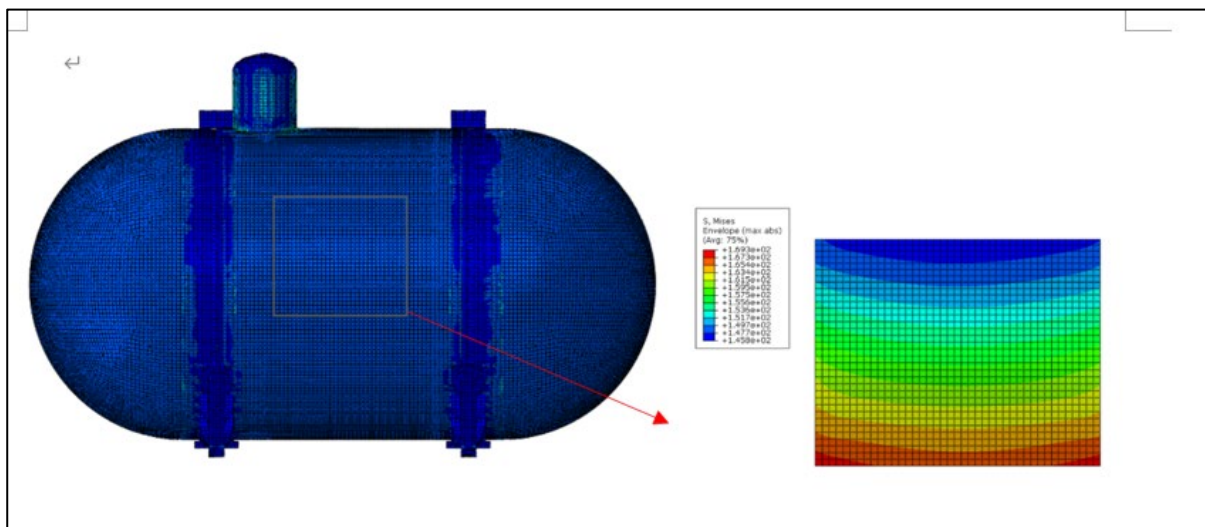

Figure 4 Stress contour for the area away from structural discontinuities

1.4.2 Y-connection

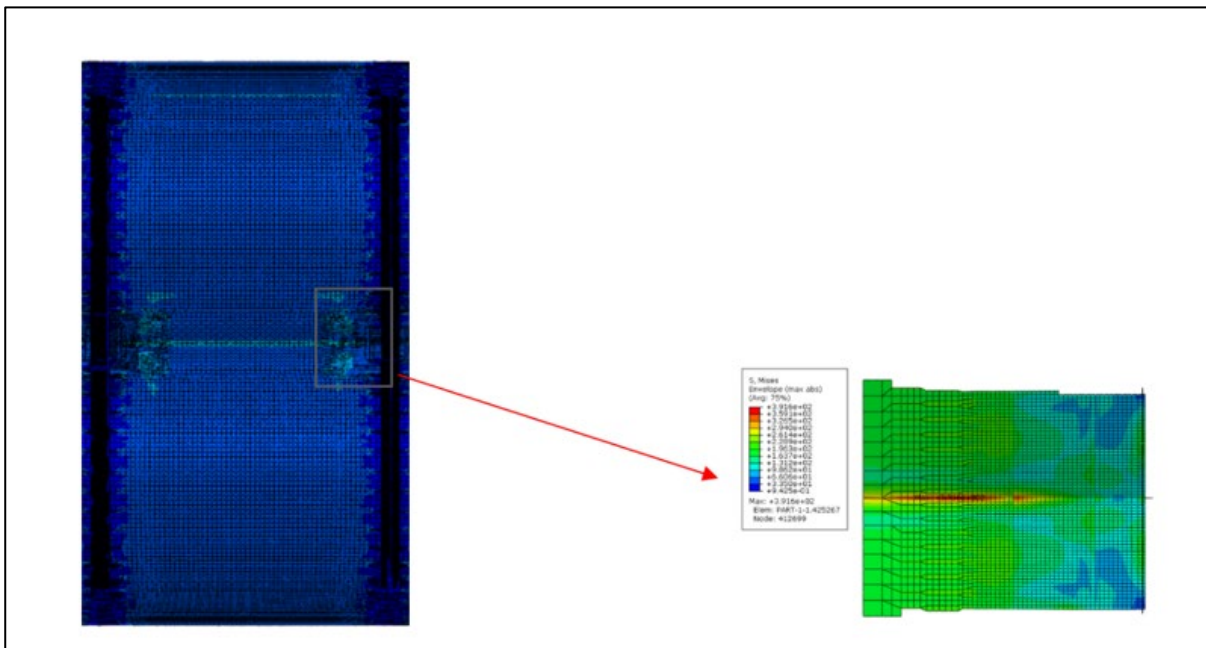

Figure 5 Stress contour for Y-connection

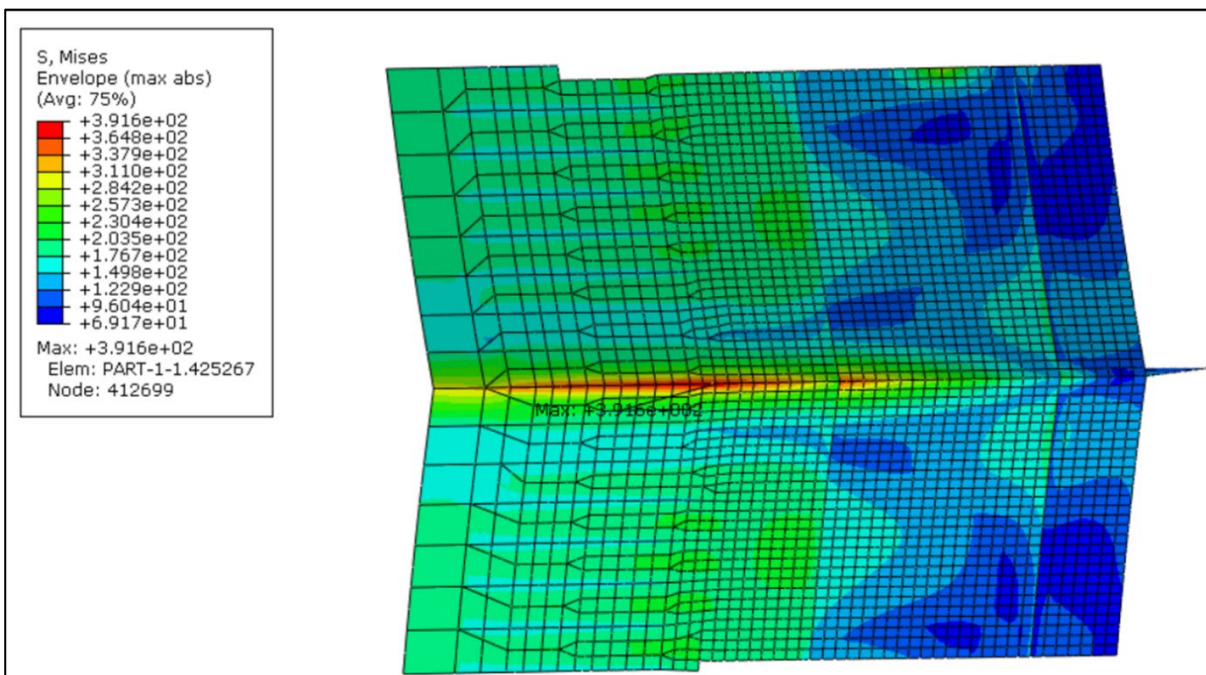

Figure 6 Stress contour for Y-connection (zoom in)

1.4.3 Wooden blocks

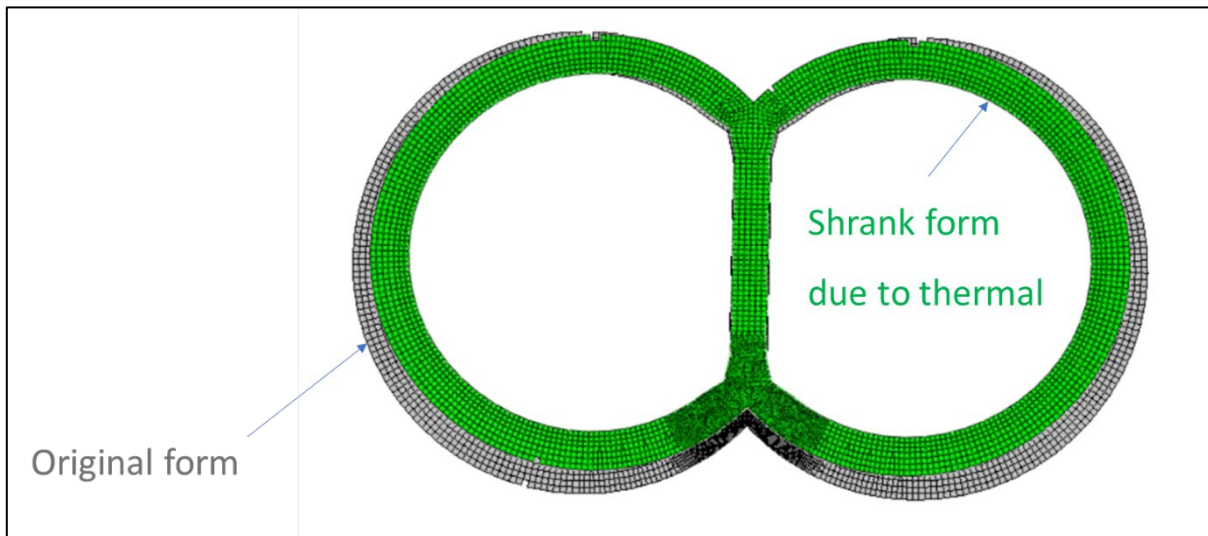

Figure 7 Effect of thermal contraction in way of heavy stiffening rings

1.4.4 Heavy stiffening rings

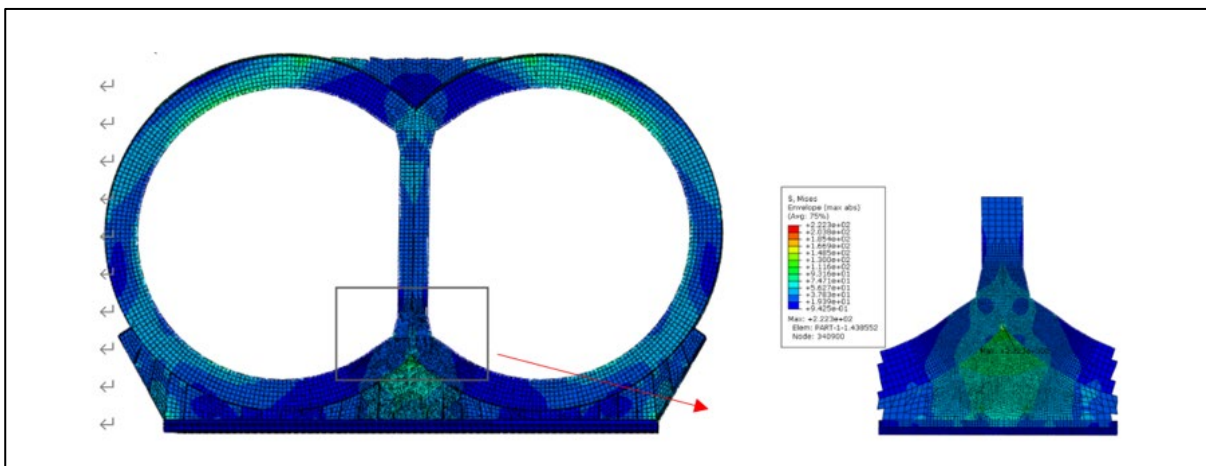

Figure 8 Stress contour for heavy stiffening rings

1.4.5 Longitudinal bulkhead

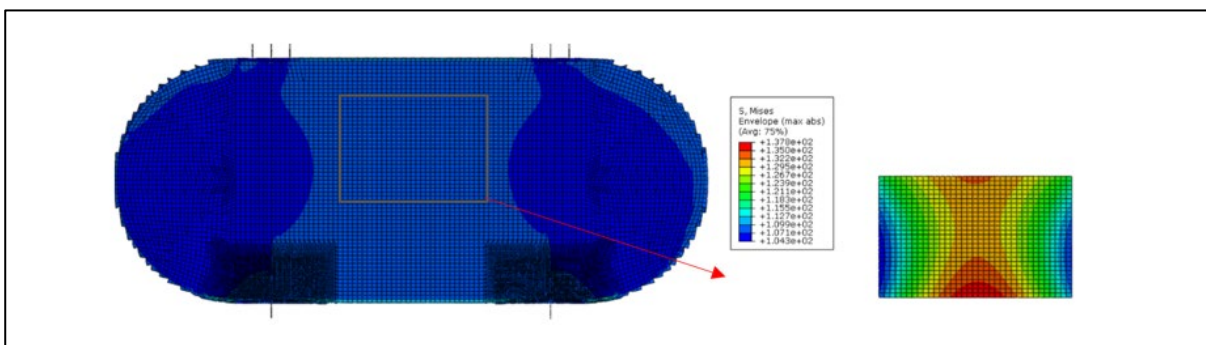

Figure 9 Stress contour for longitudinal bulkhe

2. Case 2: single cylinder type C LPG tank

2.1 Modelling

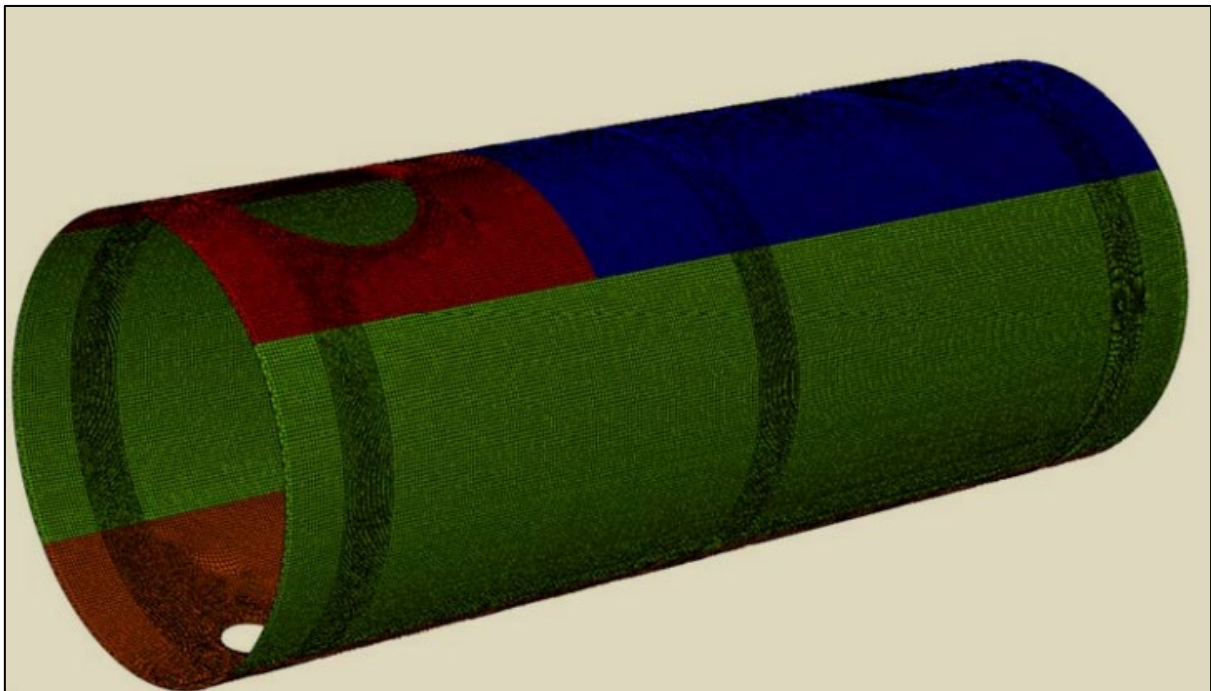
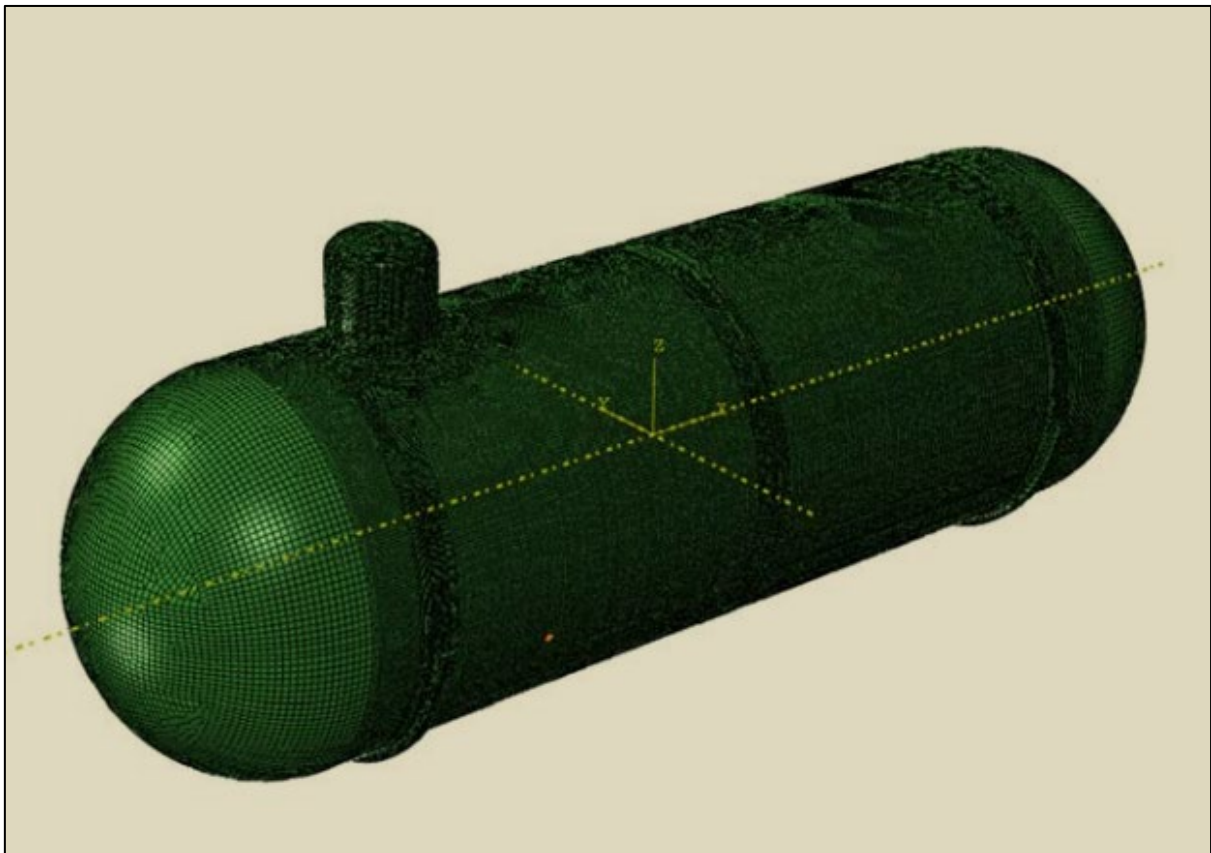

Figure 10 Finite element model of single cylinder type C LPG tank

2.1.1 Mesh size and element type

8-node shell elements are used for tank body. Mesh sizes are as follows.

- Location[A]: Areas without structural discontinuities: 200mm×200mm
- Location[B]: Area in way of structural discontinuities: 50mm×50mm ~ t x t

Solid elements are used for wooden block and the doubler plate in way of supports.

2.1.2 Boundary conditions

Contact condition for the surface between press-wood and tank support is applied.

2.2 Load cases

Load case ID	Descriptions
1	Static condition (Upright)
2	Dynamic condition (Upright)
3	30° Heeling condition
4	Collision forward case
5	Collision backward case
6	Anti-floatation condition
7	Sloshing case
8	Sloshing case

2.3 Stress results

Tab.4.1 Maximum Equivalent Stress in Case1-3

	Components		Max Stress (MPa)			
			Case1 static	Case2 dyna	Case3 dyna	Allowable stress
			Heeling 0°/MPa	Heeling 0°/MPa	Heeling 30°/MPa	/MPa
Tank Shell	Middle surface	σ_m	237.5	241.3	242.8	256.7
	Bottom surface	$\sigma_m + \sigma_b$	364.7	362.6	365.0	385
	Top surface	$\sigma_m + \sigma_b$	312.0	326.3	313.3	385
Tank Shell in way of support rings	Double-sided	$\sigma_m + \sigma_b$	312.7	349.9	384.8	385
Dome&Sump with adjacent shell	Middle surface	σ_L	366.3	369.5	366.8	385
	Bottom surface	$\sigma_L + \sigma_b + \sigma_g$	574.1	575.5	572.7	770
	Top surface	$\sigma_L + \sigma_b + \sigma_g$	675.6	687.9	674.8	770
Internal Stiffening Rings	Middle surface	σ_L	169.6	212.7	212.4	385
	Bottom surface	$\sigma_L + \sigma_b$	224.8	282.0	260.6	385
	Top surface	$\sigma_L + \sigma_b$	179.6	224.8	217.0	385
Internal Swash Bulkhead	Middle surface	σ_L	270.1	295.6	339	385
	Bottom surface	$\sigma_L + \sigma_b$	265.7	291.1	338.6	385
	Top surface	$\sigma_L + \sigma_b$	276.3	302.6	335.9	385
Outer Rib	Double-sided	$\sigma_L + \sigma_b$	63.2	101.1	158.5	385
Anti-Floatation	Double-sided	$\sigma_L + \sigma_b$	178.6	152.8	170.4	385
Wood block	Cpress		57.8	61.60	65.2	67.5
Max. Shear Stress (Abs.) of Fixed Press Wood ^[1]						

Tab.4.2 Maximum Equivalent Stress in Case4-5

	Components		Max Stress (MPa)		
			Case4 Collision forward/MPa	Case5 Collision backward/MPa	Allowable stress /MPa
Tank Shell	Middle surface	σ_m	249	246.4	256.7
	Bottom surface	$\sigma_m + \sigma_b$	360.4	321.3	385
	Top surface	$\sigma_m + \sigma_b$	350.6	366.0	385
Tank Shell in way of support rings	Double-sided	$\sigma_m + \sigma_b$	331.9	378.4	385
Dome&Sump with adjacent shell	Middle surface	σ_L	375.1	343.3	385
	Bottom surface	$\sigma_L + \sigma_b + \sigma_g$	580.2	517.0	770
	Top surface	$\sigma_L + \sigma_b + \sigma_g$	682.9	615.5	770
Internal Stiffening Rings	Middle surface	σ_L	214.5	300.5	385
	Bottom surface	$\sigma_L + \sigma_b$	284.3	329.0	385
	Top surface	$\sigma_L + \sigma_b$	226.5	316.6	385
Internal Swash Bulkhead	Middle surface	σ_L	348.2	353.1	385
	Bottom surface	$\sigma_L + \sigma_b$	332.5	337.5	385
	Top surface	$\sigma_L + \sigma_b$	365.3	370.3	385
Outer Rib &	Double-sided	$\sigma_L + \sigma_b$	101.3	342	385
Anti- Floation	Double-sided	$\sigma_L + \sigma_b$	213.1	279.3	385

Tab.4.3 Maximum Equivalent Stress in Case 6

	Components		Max Stress (MPa)			
			Case 6 Anti-float conditions/MPa	Case 7 Backward /MPa	Case 8 Forward /MPa	Allowable stress /MPa
Tank Shell	Middle surface	σ_m	53.19	217.7	218.6	256.7
	Bottom surface	$\sigma_m + \sigma_b$	118.4	368.6	372.1	385
	Top surface	$\sigma_m + \sigma_b$	76.64	321.7	317.8	385
Tank Shell in way of support rings	Double-sided	$\sigma_m + \sigma_b$	211.8	291.0	245.2	385
Dome&Sump with adjacent shell	Middle surface	σ_L	70.47	364.0	363.6	385
	Bottom surface	$\sigma_L + \sigma_b + \sigma_g$	15.1	613.2	626.3	770
	Top surface	$\sigma_L + \sigma_b + \sigma_g$	11.7	700	706.4	770
Internal Stiffening Rings	Middle surface	σ_L	118.4	151.4	153.8	385
	Bottom surface	$\sigma_L + \sigma_b$	123.6	236.5	261.3	385
	Top surface	$\sigma_L + \sigma_b$	118.2	245.8	258.6	385
Internal Swash Bulkhead	Middle surface	σ_L	83.7	325.9	280	385
	Bottom surface	$\sigma_L + \sigma_b$	86.4	373.7	279.5	385
	Top surface	$\sigma_L + \sigma_b$	83.7	348.1	288.0	385
Anti- Floatation	Double-sided	$\sigma_L + \sigma_b$	224.5	261	191.2	385

As per IGC 4.22.3.1.1, the allowable stress for structures in load case which induce,

1) primary general membrane stress σ_m is equal to:

$$\min(R_m / 3, R_{eH} / 1.5) = 256.67 \text{ MPa}$$

2) primary local membrane stress σ_L is equal to:

$$1.5 \times \min(R_m / 3, R_{eH} / 1.5) = 1.5 \times 256.67 = 385 \text{ MPa}$$

3) primary general/local membrane stress and bending stress σ_b is equal to:

$$1.5 \times \min(R_m / 3, R_{eH} / 1.5) = 1.5 \times 256.67 = 385 \text{ MPa}$$

3. Case 3: Bi-lobe Type C LNG Fuel tank

3.1 Modelling

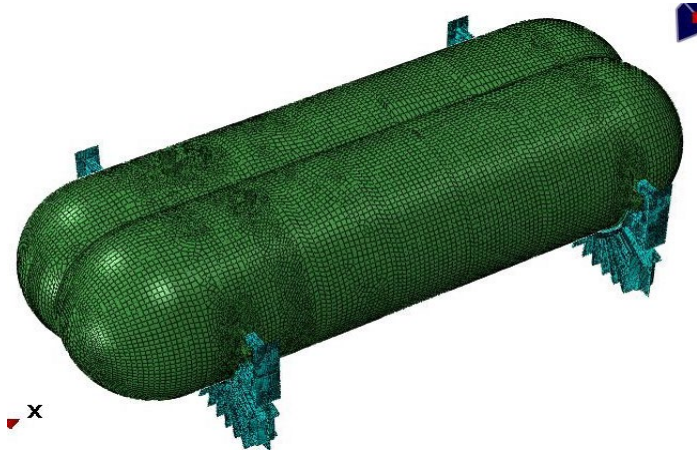

Figure 11 Finite element model of Bi-lobe Type C LNG Fuel tank

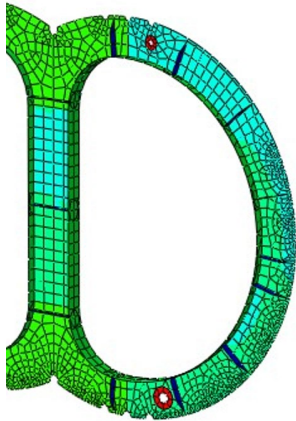

Figure 12 Heavy stiffening ring (a half part shown only)

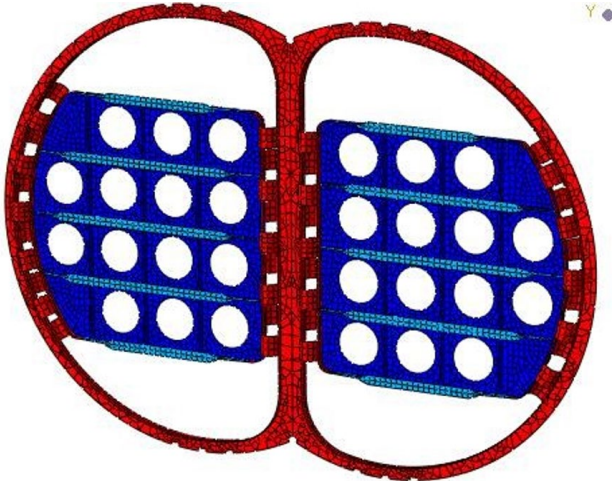

Figure 13 Inner vacuum ring and Swash BHD

3.1.1 Mesh size and element type

8-node shell elements are used for tank body. Mesh sizes are as follows.

- Location[A]: Areas without structural discontinuities: 200mm×200mm
- Location[B]: Area in way of structural discontinuities: 50mm×50mm

Solid elements (about 50×50×50 mesh size) are used for wooden block and the doubler plate in way of supports.

3.1.2 Boundary conditions

Contact condition for the surface between press-wood and tank support is applied.

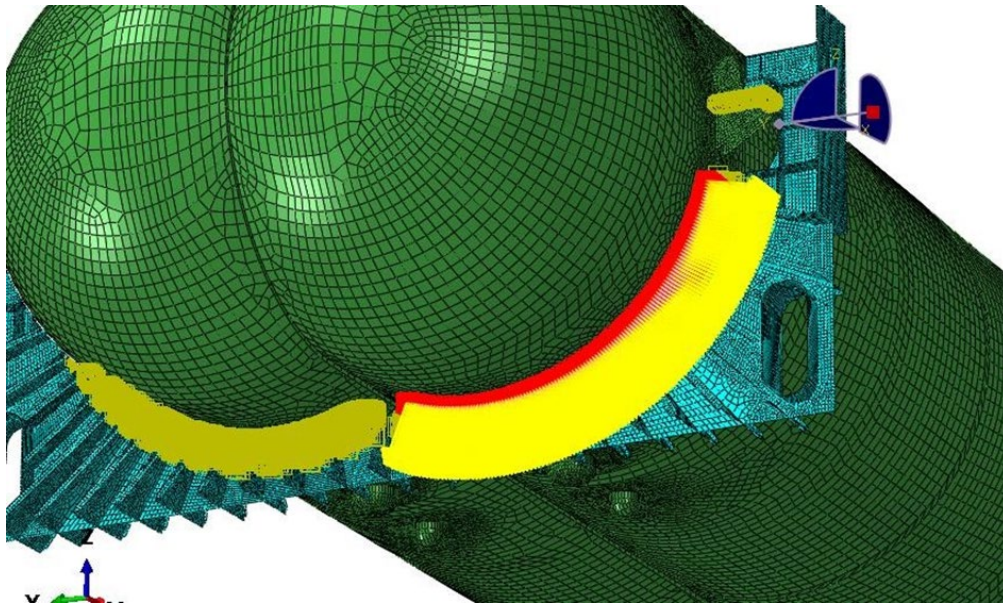

Figure 14 Contact between shell and press wood

3.2 Load cases

Load Case	Sub-case	Description	Acceleration due to ship motion	Load components
Load case 1 (ULS)	LC1-1	Static 1g, tank empty, heel 0	[0 0 -1g]	[1], [2]
	LC1-2	Static 1g, heel 0	[0 0 -1g]	[1]~[5]
	LC1-3	Static 1g, heel 30	[0 0.5g -0.87g]	
	LC1-4	Dynamic, heel 0	[0 0 -1.7315g]	
	LC1-5	Dynamic, heel 30	[0 0.8062g -1.3963g]	
Load case 2 (ALS)	LC2-1	Collision, 0.5g foreward	[0.5g 0 -1g]	
	LC2-2	Collision, 0.25g aftward	[-0.25g 0 -1g]	
	LC2-3	Anti-floating	[0 0 -1g]	
Load case 3 (Sloshing)	LC3-1	Sloshing longitudinal	[0 0 -1g]	[1]~[6]
	LC3-1	Sloshing transverse	[0 0 -1g]	
Load case 4 (Testing)	LC4-1	Hydrostatic test	[0 0 -1g]	[1], [2], [8]
Load components:				
[1] Gravity, [2] TCS gravity, [3] Design pressure, [4] Temperature field,				
[5] Liquid inertial pressure, [6] Sloshing pressure,				
[7] Test pressure, [8] Liquid pressure, [9] Buoyance.				

3.3 Stress check

3.4.1 Stress result (MPa) summary for load case 1 – ULS

Item	LC1-1	LC1-2	LC1-3	LC1-4	LC1-5	σ_{allow}	check status
Equivalent Primary General Membrane Stress σ_m [1]							
Shell	7.03	204.56	213.09	214.36	223.41	226.67	PASS
Head	2.26	195.5	201.84	209.84	211.63	226.67	PASS
Equivalent Primary Bending Stress σ_b							
Shell	4.34	55.9	47.02	54.11	45.67	340	PASS
Head	0.4	38.26	34.13	35.07	37.43	340	PASS
Equivalent Primary Local Membrane Stress σ_l							
Manhole	1.23	163.76	166.72	162.73	167.53	340	PASS
Pump	2.61	229.90	233.36	230.02	235.93	340	PASS
Sump	1.65	275.42	281.18	287.98	293.14	340	PASS
Double plate	6.47	79.04	79.52	82.87	84.71	340	PASS
Equivalent Primary General Membrane Stress and Bending Stress $\sigma_m + \sigma_b$							
Shell	11.37	260.46	260.11	268.47	269.08	340	PASS
Head	2.66	233.76	235.97	244.91	249.06	340	PASS
Equivalent Primary Local Membrane Stress, Bending Stress and Secondary Stress $\sigma_l + \sigma_b + \sigma_s$							
Manhole	2.15	236.35	240.65	234.88	242.90	680	PASS
Pump	3.30	256.44	260.55	256.60	263.30	680	PASS
Sump	1.91	287.67	295.70	300.06	307.07	680	PASS
Double plate	12.49	159.22	146.40	188.55	161.33	680	PASS
Equivalent Stress (use the current UI GC8 criterion)							
Stiffening ring	9.51	305.60	257.24	304.16	280.77	340	PASS
Vacuum Ring	31.28	261.33	274.86	273.25	290.20	340	PASS
Swash BHD	4.01	224.90	230.54	231.85	239.21	340	PASS
Note:[1]: General primary stress mainly refers to tank shell areas far away from structural discontinuities.							

3.4.2 Stress result (MPa) summary for load case 2 – ALS

Item	LC2-1	LC2-2	LC2-3	σ_{allow}	check status
Equivalent Primary General Membrane Stress σ_m ^[1]					
Shell	203.09	216.41	31.09	226.67	PASS
Head	208.02	203.56	16.25	226.67	PASS
Equivalent Primary Bending Stress σ_b					
Shell	66.54	44.64	49.46	340	PASS
Head	37.13	31.12	9.12	340	PASS
Equivalent Primary Local Membrane Stress σ_l					
Manhole	166.00	167.19	2.58	340	PASS
Pump	233.95	234.73	1.34	340	PASS
Sump	270.57	289.62	10.12	340	PASS
Double plate	83.21	79.20	41.19	340	PASS
Equivalent Primary General Membrane Stress and Bending Stress $\sigma_m + \sigma_b$					
Shell	269.63	261.05	80.55	340	PASS
Head	245.15	234.68	25.37	340	PASS
Equivalent Primary Local Membrane Stress, Bending Stress and Secondary Stress $\sigma_l + \sigma_b + \sigma_s$					
Manhole	239.74	241.13	5.73	680	PASS
Pump	260.92	261.57	2.58	680	PASS
Sump	288.10	300.31	11.41	680	PASS
Double plate	191.12	171.36	224.58	680	PASS
Equivalent Stress (use the current UI GC8 criterion)					
Stiffening ring	263.04	289.65	90.52	340	PASS
Vacuum Ring	265.00	270.21	40.84	340	PASS
Swash BHD	234.23	228.26	37.76	340	PASS
Longitudinal BHD	275.10	296.09	25.98	340	PASS
Anti-floating device	61.51	60.41	172.42	340	PASS
Note [1]: General primary stress mainly refers to tank shell areas far away from structural discontinuities.					

3.4.3 Stress result (MPa) summary for load case 3 – Sloshing condition

Item	LC3-1	LC3-2		σ_{allow}	check status
Equivalent Primary General Membrane Stress σ_m ^[1]					
Shell	209.42	211.88		226.67	PASS
Head	197.74	199.77		226.67	PASS
Equivalent Primary Bending Stress σ_b					
Shell	47.63	46.68		340	PASS
Head	36.37	64.95		340	PASS
Equivalent Primary Local Membrane Stress σ_l					
Manhole	163.13	162.54		340	PASS
Pump	229.33	231.00		340	PASS
Sump	281.20	281.27		340	PASS
Double plate	79.37	80.81		340	PASS
Equivalent Primary General Membrane Stress and Bending Stress $\sigma_m + \sigma_b$					
Shell	257.05	258.56		340	PASS
Head	234.47	264.72		340	PASS
Equivalent Primary Local Membrane Stress, Bending Stress and Secondary Stress $\sigma_l + \sigma_b + \sigma_s$					
Manhole	235.29	233.46		680	PASS
Pump	255.84	255.90		680	PASS
Sump	292.24	294.71		680	PASS
Double plate	169.57	155.08		680	PASS

Equivalent Stress (use the current UI GC8 criterion)					
Stiffening ring	283.99	262.17		340	PASS
Vacuum Ring	265.67	267.90		340	PASS
Swash BHD	234.23	228.26		340	PASS
Longitudinal BHD	275.10	296.09		340	PASS
Anti-floating device	61.51	60.41		340	PASS

Note [1]: General primary stress mainly refers to tank shell areas far away from structural discontinuities.

3.4.4 Stress result (MPa) summary for load case 4 – Testing

Item	σ	75% of yield	90% of yield	Remark
Equivalent Primary General Membrane Stress $\sigma_m^{[1]}$				
Shell	320.37	300	360	PASS
Head	295.09	300	360	PASS

Note [1]: General primary stress mainly refers to tank shell areas far away from structural discontinuities.

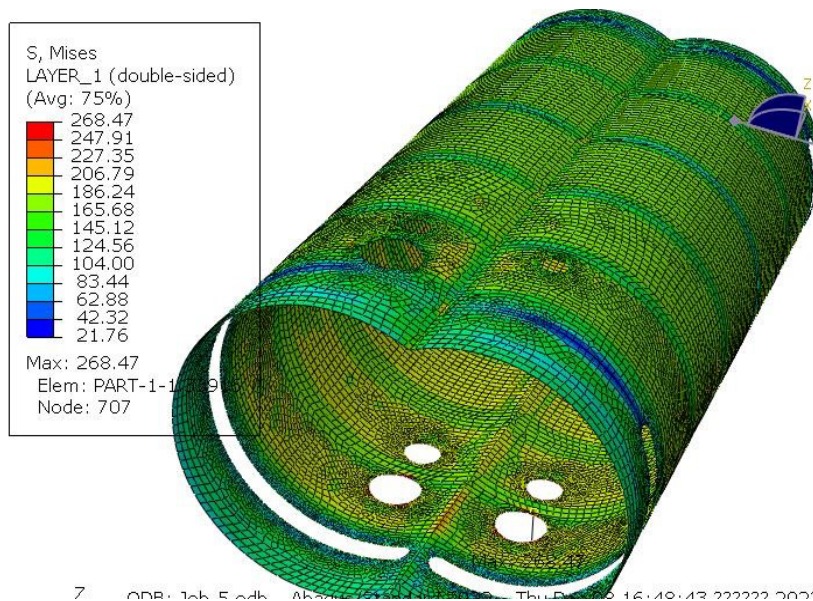

Figure 15 $\sigma_m + \sigma_b$ at Y-connection in LC1-4 (0, ay, -g)

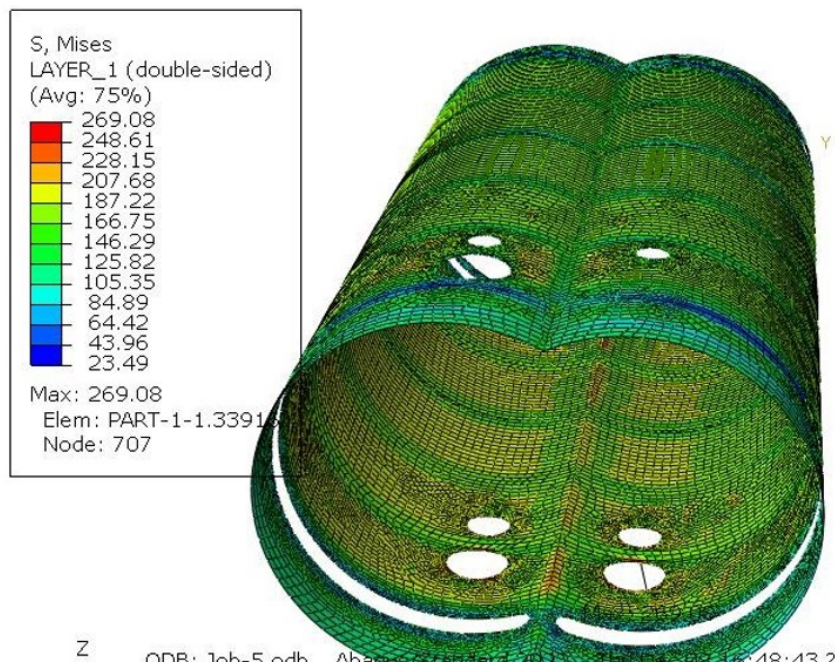

Figure 16 $\sigma_m + \sigma_b$ at Y-connection in LC1-5 (0, ay, -az)

4. Conclusion

Specific location of structural discontinuities, for example the domes and sumps, are not assessed by finite element analysis because the prescriptive requirements are applied.

From the case study, the analysis procedures for modelling, boundary conditions, design loads and load combinations outlined in the recommendation are found to be in order with acceptance criteria for yielding assessment defined in UI GC8A and Rec.174.

Attachment 2

The case study/consequence assessment report on Type C tank for FE application (non-linear buckling analysis)

This chapter presents the non-linear buckling analysis examples designed to show how the procedure presented in the Rec. No. 174 can be applied in a real project. The cases cover three parts including a cylindrical shell, spherical shell, and stiffening ring of type C tank.

1. Model information

The specification and material characteristics of example model for type C tank are as below in Table 1 and Table 2.

Table 1 Specification of Example Model for Type C Tank

Tank Type	Type C Tank
Design Vapour Pressure(MPa)	0.9
Design External Pressure(MPa)	0.1
Cargo Temperature(Deg)	-163
Cargo Density	0.5
Insulation	Vacuum Type
Head Type	Semi-spherical
Corrosion Allowance(mm)	1.0
Length (distance between the stiffening rings) (mm)	1,000
Diameter of Shell(mm)	2,400
Thickness of Shell(mm)	8.0
Radius of Head(mm)	1,200
Thickness of Head(mm)	8.5
Size of Stiffening Ring(mm)	120x7+120x7(T)

Table 2 Characteristics of Tank Material

Material	SUS 304
Poisson's Ratio	0.3
Young's Modulus(MPa)	200,000
Yield Strength(MPa)	205
Tensile Strength(MPa)	520

The description of the example model is as below in Figure 1.

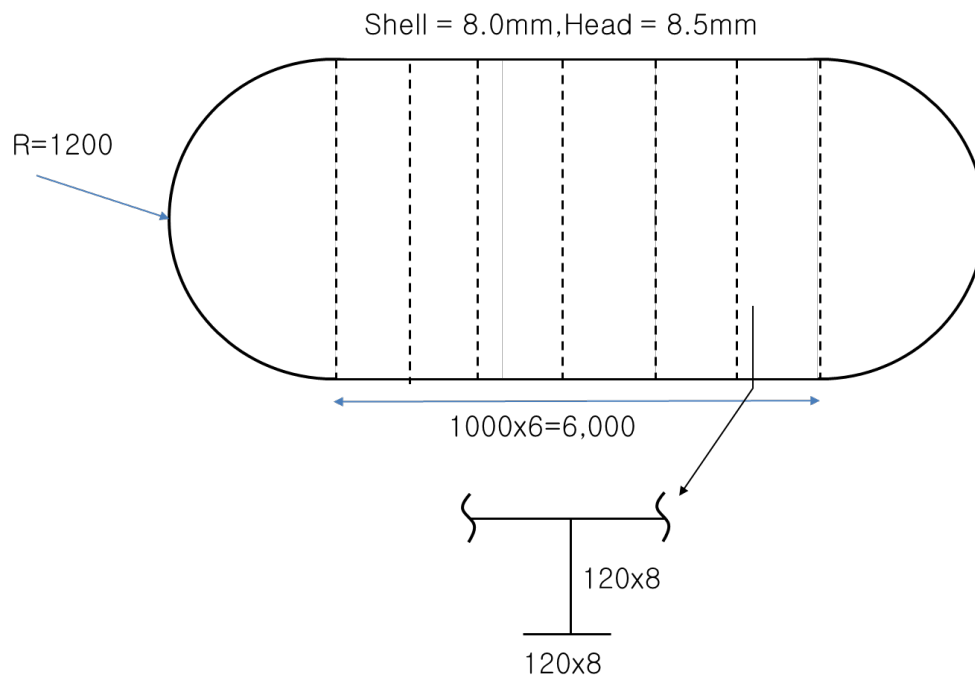

Figure 1 Description of Example Model for Type C Tank

2. Scantling of shells and stiffening rings under external pressure

2.1 Buckling check for cylindrical shell

This example illustrates the determination of cylindrical shell thickness based on the above model information.

According to UI GC8B 2.1, the critical buckling pressure for stiffening ring is to be taken as :

$$P_c = \frac{1}{3} \left[n^2 - 1 + \frac{2n^2 - 1 - \nu}{n^2 \left(\frac{2L}{\pi D} \right)^2 - 1} \right] \frac{2E}{(1 - \nu^2)} \left(\frac{t}{D} \right)^3 + \frac{2E \frac{t}{D}}{(n^2 - 1) \left[n^2 \left(\frac{2L}{\pi D} \right)^2 + 1 \right]^2}$$

where:

D=outside diameter of the cylindrical shell, in mm, based on gross scantling

t=net thickness of the cylindrical shell, in mm, exclusive of corrosion allowance

E=Young's modulus, in N/mm²

ν =Poisson's ratio

n= number of circumferential buckling waves. It is to be taken as the integral value to minimize the critical pressure P_c with $n \geq \text{Max} \left(2, \frac{\pi D}{2L} \right)$.

L=effective distance between stiffening rings, in mm

In the given expression above, enter the values given in Table 1 and Table 2. Then, it is necessary to find the minimum value of P_c by iterative calculation. This process is summarized in Table 3 and Figure 2.

Table 3 Iterative Calculation to find the Minimum Value of P_c

n	P_c	n	P_c
2	243.90	22	1.92
3	56.17	23	2.09
4	18.70	24	2.26
5	6.91	25	2.45
6	3.05	26	2.64
7	1.59	27	2.84
8	1.00	28	3.04
9	0.76	29	3.25
10	0.68	30	3.47
11	0.68	31	3.70
12	0.72	32	3.94
13	0.79	33	4.18
14	0.87	34	4.43
15	0.97	35	4.69
16	1.08	36	4.96
17	1.20	37	5.23
18	1.33	38	5.51
19	1.46	39	5.80
20	1.61	40	6.09
21	1.76		

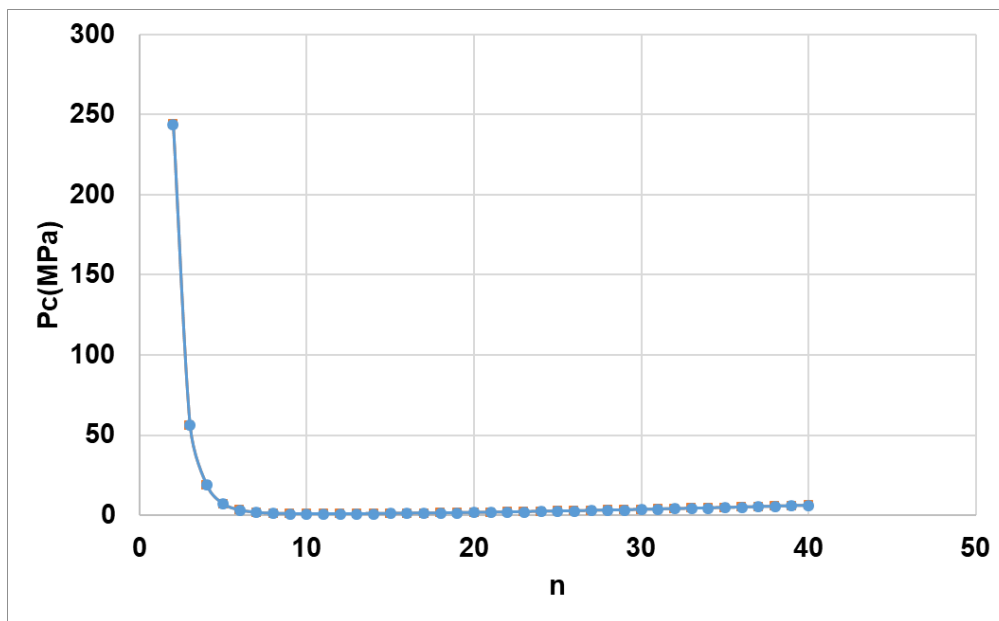

Figure 2 Values of Pc

As a result, the calculated critical buckling pressure for the cylindrical shell is 0.68(Mpa). According to UI GC8B 2.4, the calculated safety factor for the example model is 6.8 and it is satisfied to the required safety factor 4.0.

2.2 Buckling check for spherical shell

According to UI GC8B 2.2, the critical buckling pressure for stiffening ring is to be taken as:

$$P_c = 1.21E \left(\frac{t}{R} \right)^2$$

where:

R=outside radius of the sphere shell, in mm, based on gross scantling. For torispherical and ellipsoidal ends, the radius is taken the radius of the crown.

E=Young's modulus, in N/mm²

t=net thickness of the spherical shell, in mm, exclusive of corrosion allowance

In the given expression above, enter the values given in Table 1 and Table 2. As a result, the calculated critical buckling pressure for the spherical shell is 9.45(MPa). According to UI GC8B 2.4, the calculated safety factor for the example model is 94.5 and it is satisfied to the required safety factor 15.0.

2.3 Buckling check for stiffening ring

According to UI GC8B 2.3, the critical buckling pressure for stiffening ring is to be taken as :

$$I = \frac{0.18D^3LP_{ex}}{E}$$

where:

D = outside diameter of the cylindrical shell, in mm, based on gross scantling

E =Young's modulus, in N/mm^2

L =effective distance between stiffening rings, in mm

P_{ex} =external design pressure of shell, in MPa

The width of shell, in mm, contributing to the moment of inertia shall not be greater than $0.75\sqrt{Dt}$, where t =net thickness of the cylindrical shell, in mm, exclusive of corrosion allowance.

In the given expression above, enter the values given in Table 1 and Table 2. As a result, the required moment of inertia for the stiffening ring is 1,207,922(mm^4). The actual moment of inertia is 7,095,000 (mm^4), which satisfies the requirements of UI GC 2B 2.3.

3. Buckling strength assessment by non-linear finite element analysis

3.1 Modelling

The description of the example model is as below in Figure 3.

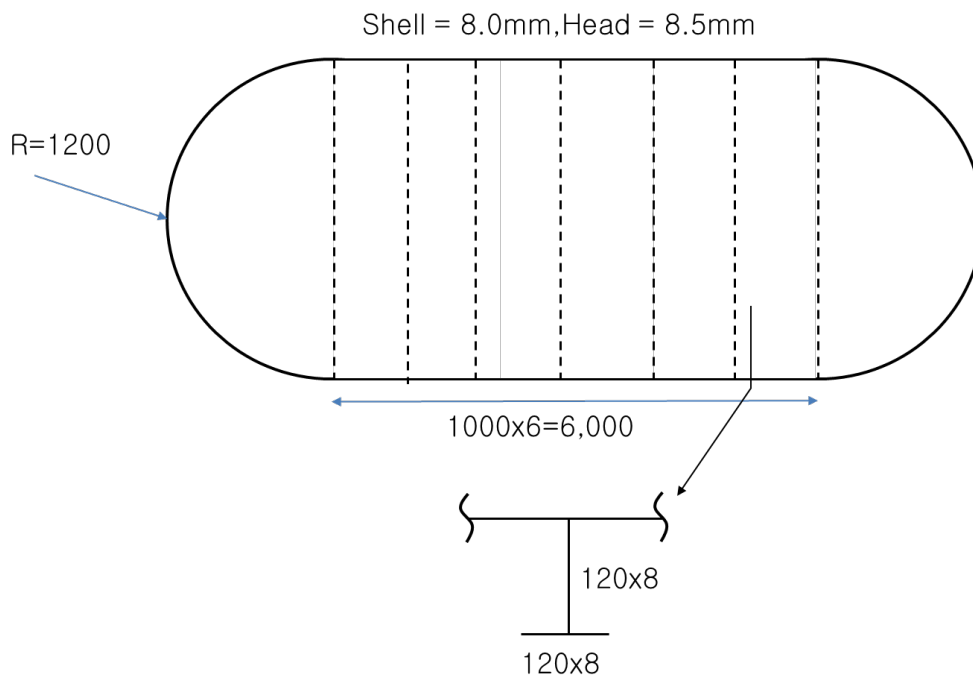

Figure 3 Description of Example Model for Type C Tank

The FE models for the cylindrical shell, spherical shell and stiffening ring are shown in Figure 4 ~ 6 below. Also, the boundary condition and idealization of stiffening ring are shown in Figure 7 ~ 8 below.

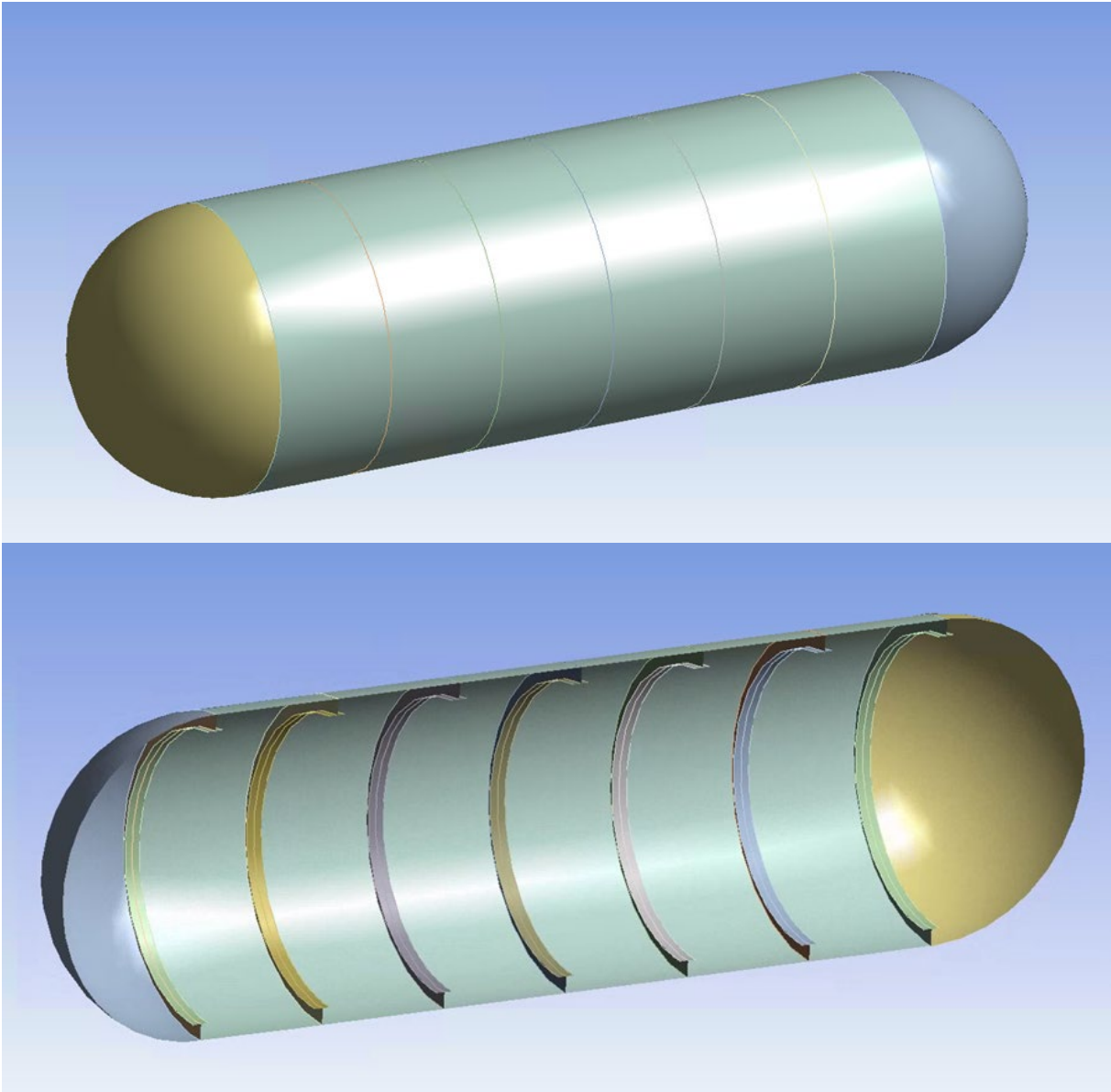

Figure 4 FE Model of Cylindrical Shell

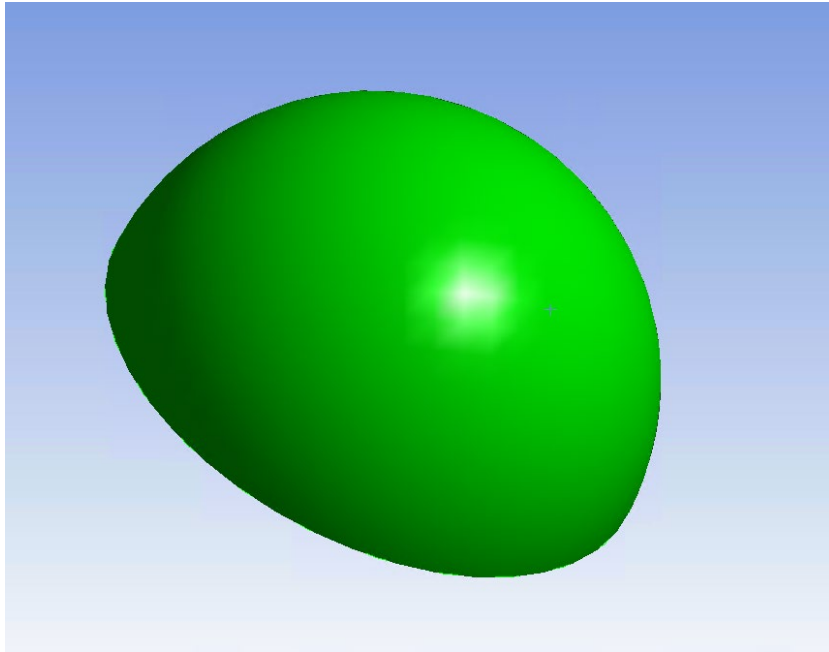

Figure 5 FE Model of Spherical Shell

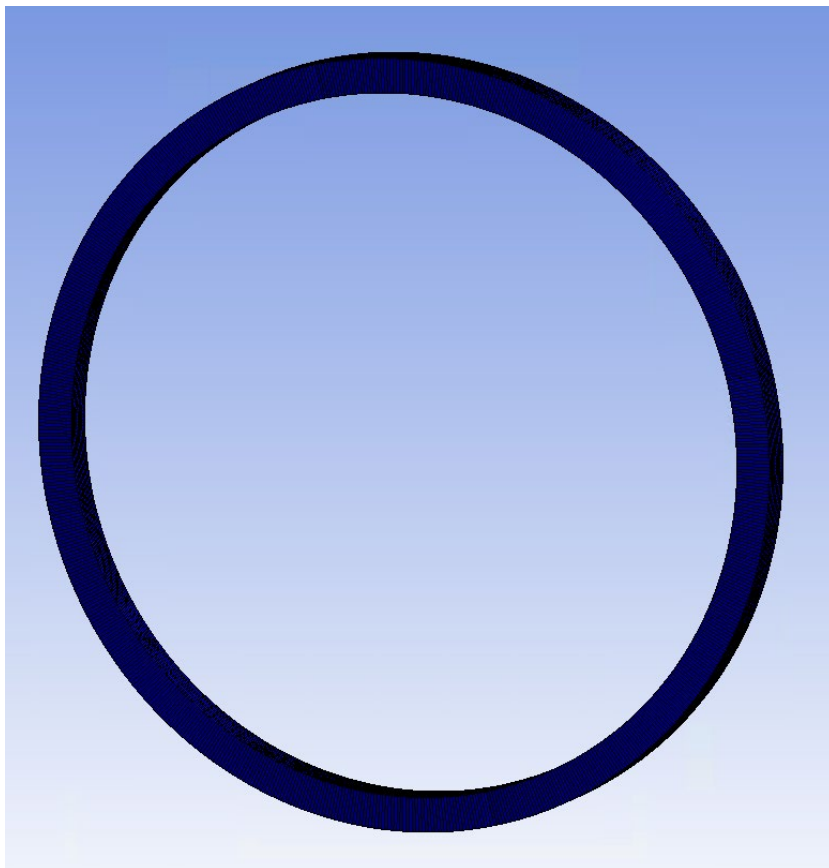

Figure 6 FE Model of Stiffening Ring

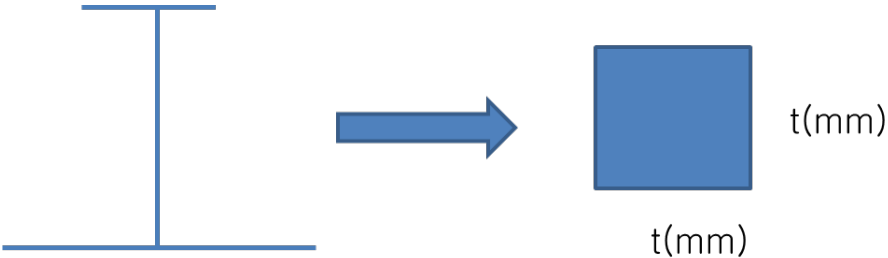
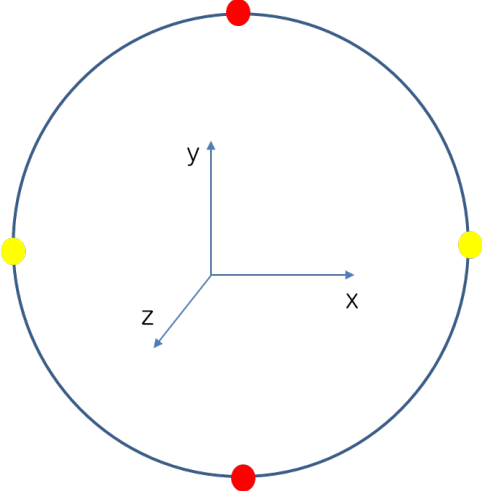

Figure 7 Idealization of Stiffening Ring

All : $dz=\text{fixed}$
Edge: $\theta_x, \theta_y=\text{fixed}$

● $dx, dz:\text{fixed}$
● $dy, dz:\text{fixed}$



Boundary Condition

Figure 8 Boundary Condition of FE Model

3.2. Buckling check for cylindrical shell

3.2.1. Linear buckling analysis

Firstly, a linear buckling analysis is performed in order to provide data for initial imperfection pattern as shown in Figure 9. The results are used as input for a nonlinear analysis.

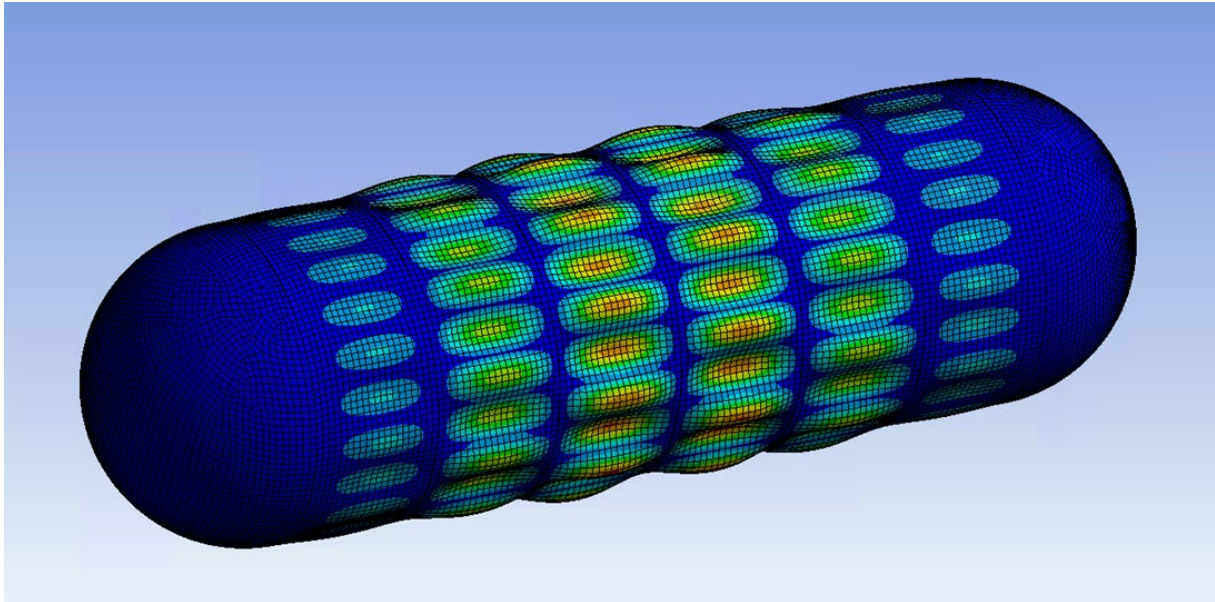

Figure 9 Buckling Mode of Cylindrical Shell by Linear Buckling Analysis

3.2.2. Application of Initial Imperfection

An initial imperfection has to be included to take into account possible initial deformations from the fabrication of the type c tank. However, it is practically difficult to accurately determine the pattern and size of the initial deformation that occurs in the actual manufacturing process. Therefore, a method of applying the maximum size of deformation specified in each classification's rule to the initial deformation pattern obtained from the linear analysis is used. In this example, an initial deformation in which the difference between the maximum and minimum diameters is 1% was applied.

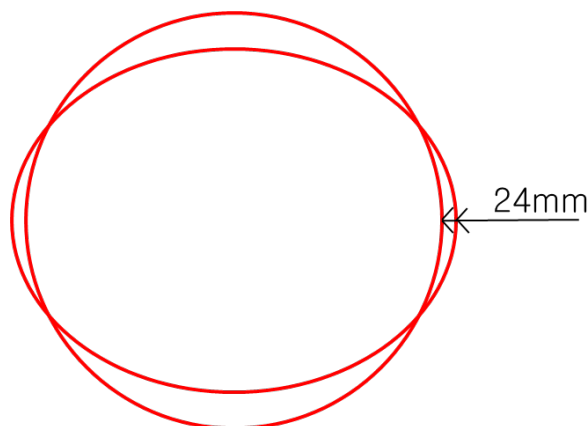

Figure 10 Application of Initial Imperfection

3.2.3. Nonlinear FEA Analysis

The behavior of a buckling system is reflected in the shape of its load- displacement curve as shown in Figure 11. In addition, the shape of the final buckling is shown in Figure 12 below. It is difficult to accurately define the structural buckling capacity in a nonlinear buckling. The buckling capacity of the cylindrical shell shall be determined by the section in which the load - deformation curve is stabilized. Therefore, in the curve below, the buckling capacity is finally determined to be 0.417 (MPa).

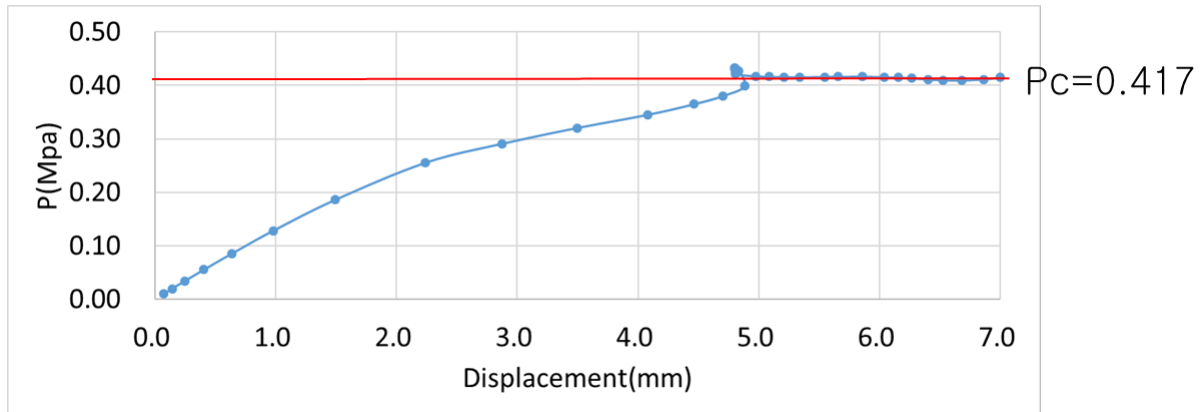

Figure 11 Load - Displacement Curve for Cylindrical Shell

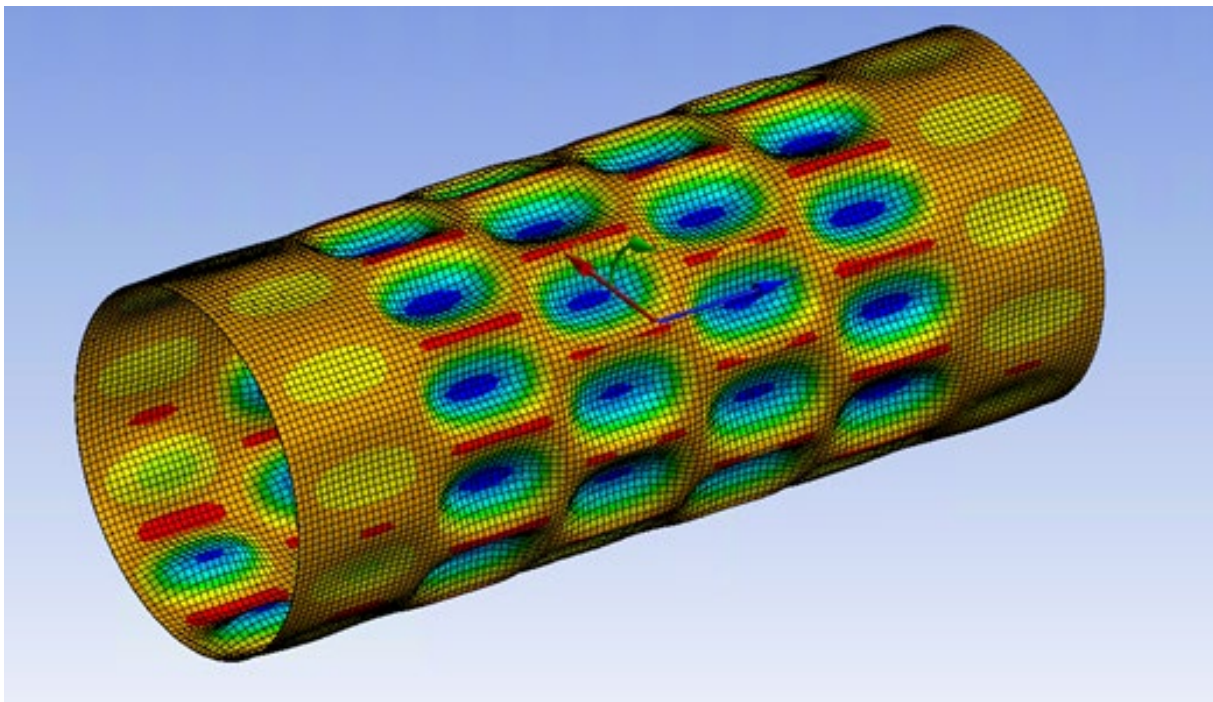

Figure 12 Buckling Result of Cylindrical Shell by Nonlinear FEA Analysis

3.3. BUCKLING CHECK FOR SPHERICAL SHELL

Linear analysis was performed on the spherical shell to obtain the pattern of initial deformation in the same manner as the procedure applied to the cylinder shell.

The results of the linear analysis are shown in Figure 13 below.

The same initial deformation as the cylindrical shell is applied to the buckling pattern obtained from linear analysis.

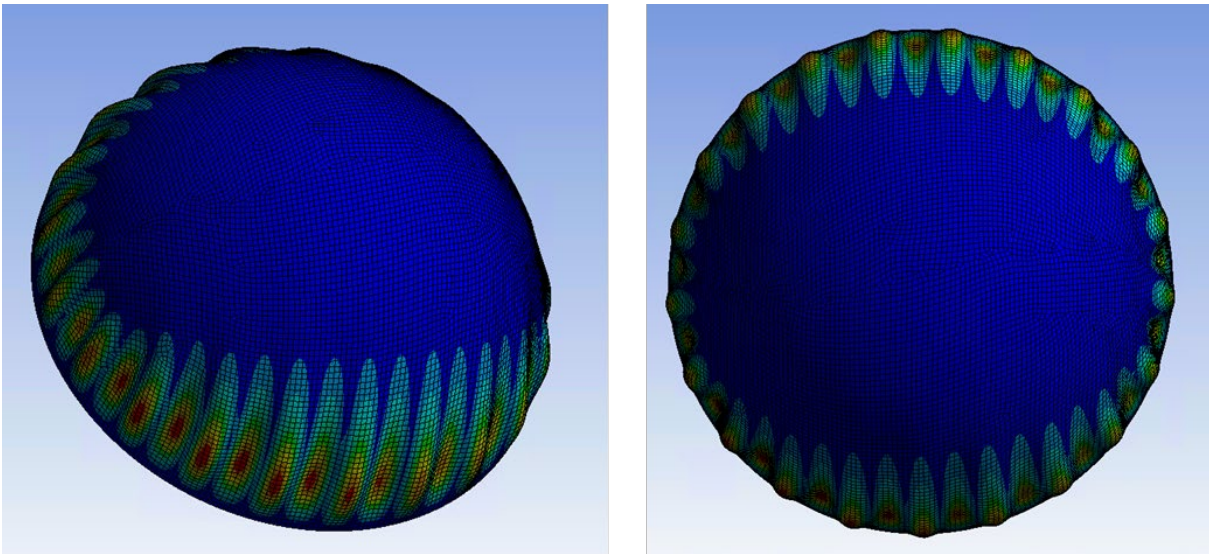

Figure 13 Buckling Mode of Spherical Shell by Linear Buckling Analysis

The load deformation curve and buckling shape for the spherical shell are shown in Figure 14 and 15 below, respectively. Finally, the buckling capacity is determined to be 0.68 (MPa).

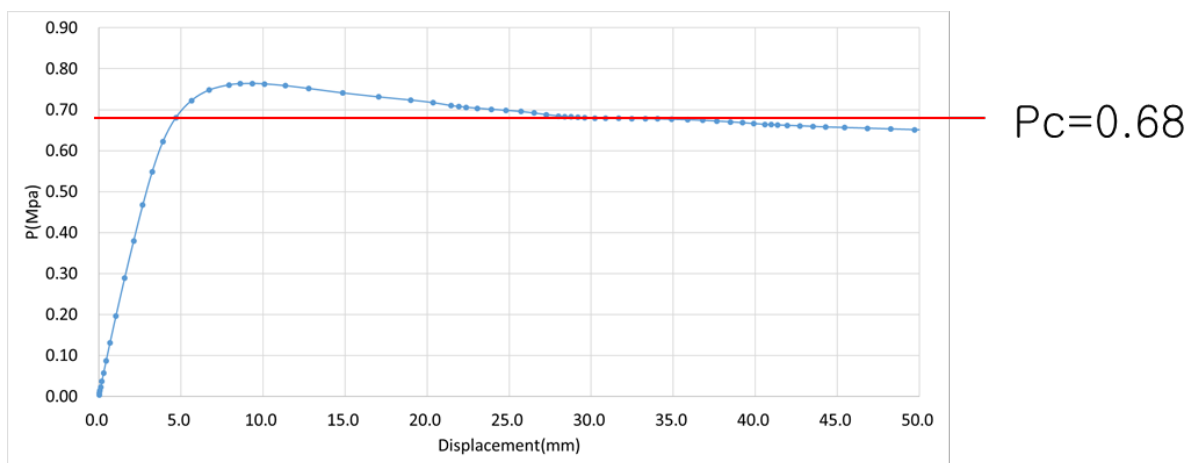

Figure 14 Load - Displacement Curve for Spherical Shell

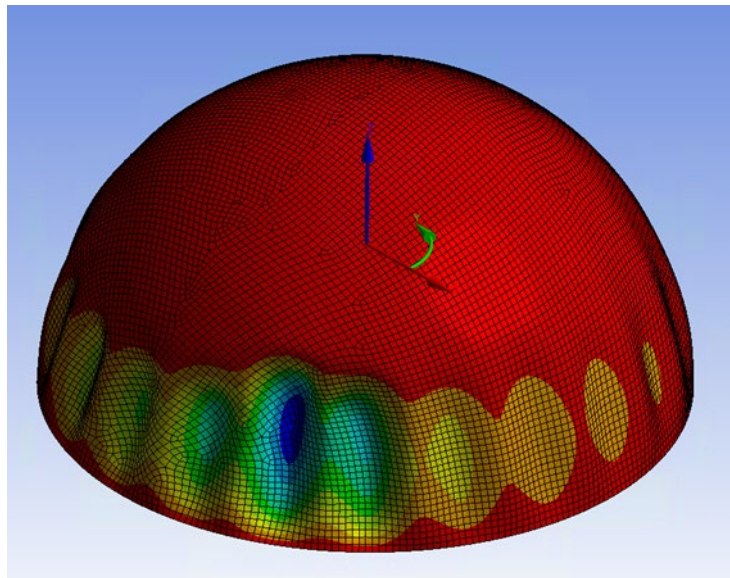

Figure 15 Buckling Result of Spherical Shell by Nonlinear FEA Analysis

3.4. BUCKLING CHECK FOR STIFFENING RING

Linear analysis was performed on the stiffening ring to obtain the pattern of initial deformation in the same manner as the procedure applied to the cylinder shell.

The results of the linear analysis are shown in Figure 17 below. Finally, the buckling capacity is determined to be 10.26 (MPa).

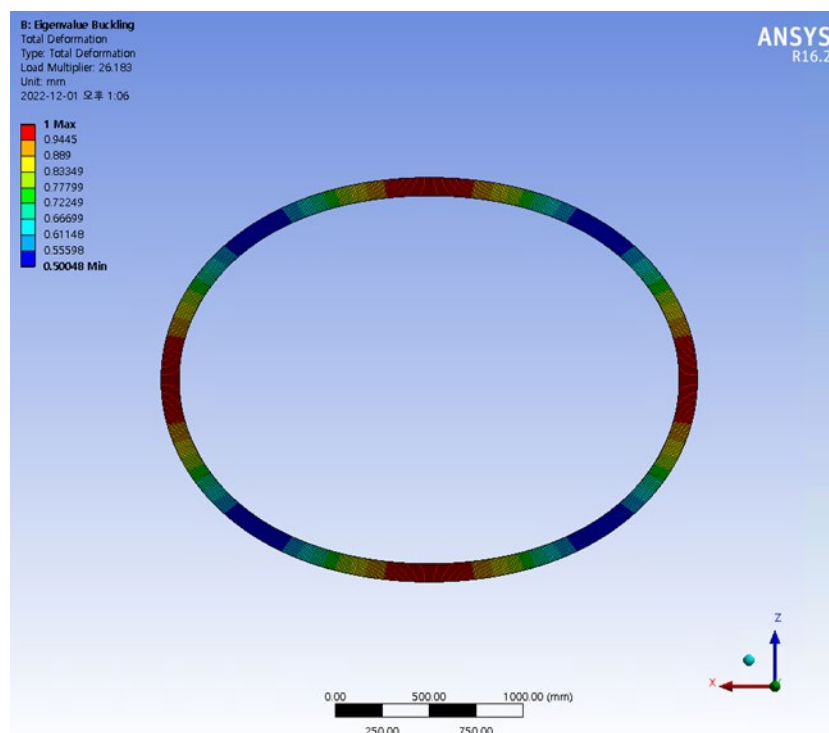

Figure 16 Buckling Mode of Stiffening Ring by Linear Buckling Analysis

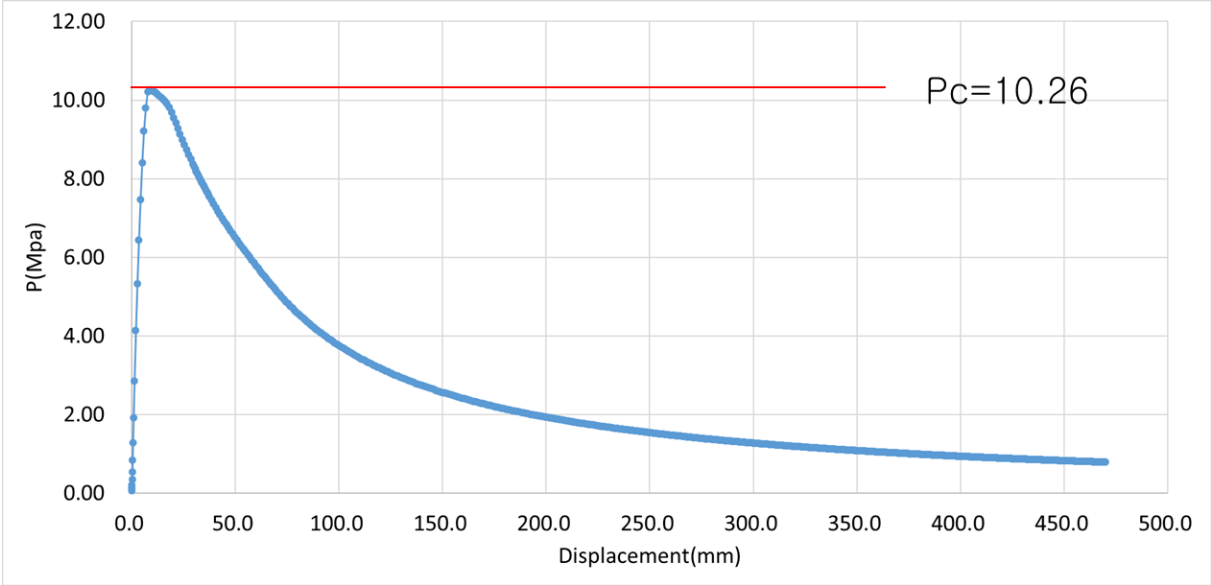

Figure 17 Buckling Result of Stiffening Ring by Nonlinear FEA Analysis

Attachment 3

The case study/consequence assessment report on Type C tank for FE application (FE fatigue assessment)

1. Finite elements analysis

The prescriptive formula of the "design vapour pressure" defined in the IGC code 4.23.1.2 is intended to provide a simple design of a type C tank sufficient fatigue strength capacity without further detailed finite element analysis. However, for larger type C tanks and with more complex designs the "Design vapour pressure" do not cover local hotspots and complex support stresses. If the design includes elements that are outside the limitations of the prescriptive formulas it is often required to document the tank design with finite elements calculations.

The analysis and modelling of a type C-tank will depend on the type of tank and the support design of the tank. In addition, the design temperature of the tank may affect the way how the tank is modelled. A few typical tank designs applications are described below:

- a) Single cylinder type-C tank on a typical support cradle with woodblock between tank and cradle
- b) Single cylinder tank designed with a vacuum insulated outer jacket. The support between inner tank and outer jacket of a fully welded design
- c) Single cylinder tank designed with a vacuum insulated outer jacket. The support between inner tank and outer jacket designed with blocks or other contact surfaces elements
- d) Multi-lobe tanks

2. Supports made of contact surfaces

If the tank is placed on supports that can be considered as contact surfaces the relative deflections between the tank and supports need to be correctly considered especially for low temperature applications and for large diameter tanks. The relative deflection between the tank and the supports may significantly affect the stress distribution and need to be correctly modelled, see deflection plots illustrated in figure 1.

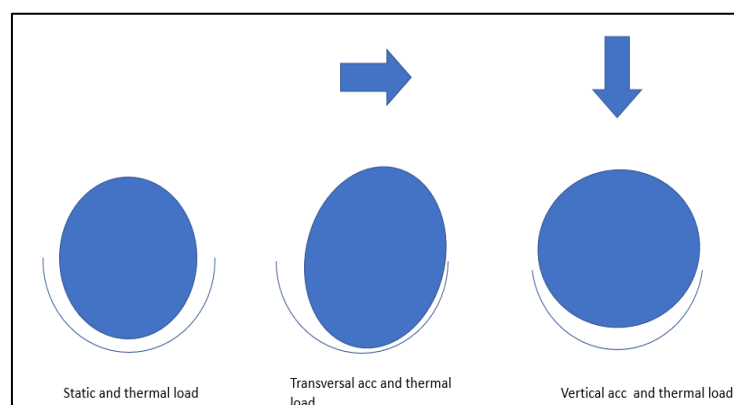

Figure 1 The figure illustrate the natural cylindrical tank deflections due to accelerations in transverse and vertical direction. The relative deflections between tank and supports may significantly affect the load distribution and the local stresses on the tank and the tank supports. A correct modelling of the contact between tank and support is therefore important to capture these effects.

In Figure 1 the relative deflections between tank and tank supports may significantly influence the local stress distribution on the tank and its supports. These effects become increasingly important with low design temperatures of the tank and for large diameter tanks. Depending on the capabilities of the applied FE program the contact surfaces can be modelled in several different ways. Some alternatives are listed below.

- Spring elements
- Compression – no tension beams
- Contact surfaces allowing for physical gap clearance

The first alternative with spring element will often require an iteration process to detach elements that are in tension and then re-run the analysis, check again that there are again no springs that are in tension. If the second alternative is used with compression elements the iteration process is normally avoided.

The best solution is to apply the “contact surface” modelling. For each support modelling technique, deflection plots should be used to verify that the physics of the tank and supports are realistically modelled. It shall also be evaluated if large deflections/large gaps can be correctly handled by the finite element program, i.e. that after cooldown, the finite element program can handle the support condition as a new reference correctly.

3. Mesh size for modelling type C tanks

FE-Modelling of a pressurized tank requires an understanding of the physics behind the stresses of importance. The standard FE-modelling techniques applied for ship building may not be directly applicable when modelling a type C tank as the FEM modelling of a ship is based on a different strength assessment.

Ship structures are built based on girders, stiffeners and plate strength design elements. The FEM analysis for a ship structure is mainly to determine the stresses in the girder and stiffener construction. The stresses in plates in FE analysis of ships are normally not correctly modelled. The plate strength is often dimensioned by local prescriptive calculations. The construction elements in a ship structure are also normally designed to carry loads in one dominating load direction.

In a pressure vessel, such as Type C tanks, the structure is carrying the loads mainly as membrane stresses and the local high stressed locations are primarily caused by local plate bending effects in the tank shell. Therefore, a relevant finite element model for a pressure vessel will often require a mesh that is able to capture through thickness local bending of the plate. The mesh size will need to be based on a finer mesh and the through thickness stresses due to plate bending need to be appropriately determined.

The field of stresses in a pressure vessel is often multidirectional without one dominating stress direction. For fatigue strength evaluation this is particularly important to consider as the driving stress for fatigue evaluations is the stress range. The determination of stress range requires therefore a careful assessment including the sign and direction of principal stresses to correctly evaluate relevant stress range.

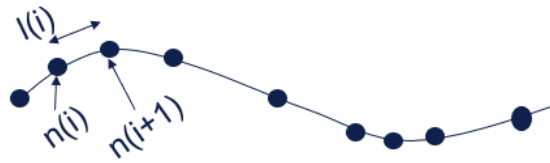

Figure 2 The figure illustrate an alternative method on how to determine if the mesh lengths $l(i)$ in the model is sufficiently small. The nodes are illustrated as points $n(i)$. With the correct mesh size the deformation of the loaded structure shall be well described by the deflections plotted by the deformed mesh.

There is not necessary an absolute value on the mesh size applicable for type C-tanks (see Figure 2). For fatigue stress evaluation the thickness of plate often used as an indication of the required mesh size at highly loaded locations. This can often be used as a rule of thumb. But to verify that a correct mesh size has been applied is to evaluate the deflection of the stressed area. If the mesh size is correct the deflections should be realistically determined by the FEM model.

4. Shell elements

For 8-node shell elements and 4-node shell elements with additional internal degrees of freedom for improved in-plane bending behaviour, a mesh size from $t/2$ up to $2t$ may be used. For conventional 4-node elements, a mesh size from $t/2$ to t may be used. Larger mesh sizes at the hot spot region may provide nonconservative results.

5. Solid elements

An alternative, particularly for complex geometries, solid elements are often necessary. These need to have a displacement function capturing steep stress gradients, e.g. by using linear plate bending stress distribution in the plate thickness direction.

This is offered, e.g. by iso-parametric 20-node elements (with mid-side nodes at the edges), which mean that only one element in plate thickness direction is required. An easy evaluation of the membrane and bending stress components is then possible if a reduced integration order with only two integration points in the thickness direction is chosen. A finer mesh sub-division is necessary particularly if 8-node solid elements are selected. Here, at least four elements are recommended in the thickness direction.

Modelling of the welds is generally recommended as shown in Figure 9. For modelling with solid elements, the dimensions of the first two or three elements in front of the weld toe should be chosen as follows. The element length may be selected to correspond to the plate thickness. In the transverse direction, the plate thickness may be chosen again for the breadth of the plate elements.

However, the breadth should not exceed the attachment width, i.e. the thickness of the attached plate plus two times the weld leg length (in case of type c in Figure 9: The thickness of the web plate behind plus two times the weld leg length). The length of the elements should be limited to $2 \cdot t$.

It is recommended that also the fillet weld is modelled to achieve proper local stiffness and geometry. Attention should be made at transition area between solid elements and

shell elements if integrated to make sure that the stiffness is correctly transferred between the two models. A good “rule of thumb” is to keep the transition area between the two element types away from the areas with high stresses.

6. Modelling of doubler plates

It is often necessary to model doubler plates at supports physically correct when plate bending stresses are significant in the area where doubler plates are applied. This is illustrated in one of the examples described below. Modelling of doubler plates physically correct requires usually that solid elements are applied. The welds connecting the doubler plates with the tank shell need to be physically modelled. It is in general beneficial to model the tank shell plate with the welds as one solid model and the doubler plate as a second solid model. The application of how nodes in contact and connected nodes are defined are essential. This example is based on application of ABACUS. The example shows how this can be done.

- The CONTACT should be used where you want surfaces to either push against each other, without nodes penetrating the elements on the opposite surface, or slide. The mesh is not connected (or should not be).
- The TIE should be used where you do NOT want any movement. In general that should be between regions which *could* be modelled as one continuous mesh, but for various reasons are not, for instance where it is easier to build a model by assembling different parts with different mesh densities, etc.

7. Load cases

The basis for evaluating the fatigue strength of a design is to determine the representative stress range. The stress range is usually determined based on an evaluation of two load cases including both static and dynamic loads. The two load cases are defined with the dynamic loads applied with opposite sign. The stress range will have to consider the principal stress amplitudes with the correct sign. As stress fields are in general multidirectional, the principal maximum and minimum stresses often switch direction when the dynamic loads change sign (see Figure 3). Accordingly, the maximum or minimum principal stress within a sector of +/- 45 degrees to the hot spot will have to be evaluated to determine the stress range (see illustration in Figure 3).

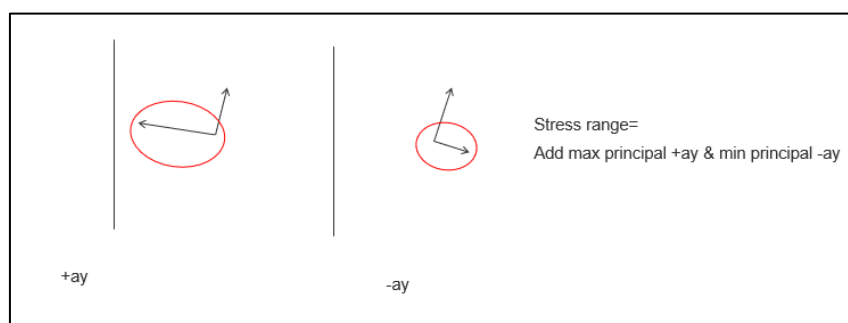

Figure 3 The figure illustrate maximum and minimum stresses at a location for two dynamic load cases (dynamic horizontal accelerations) where the dynamic load is first with a positive sign (left) and then with negative sign (right). It is seen in the figure that it is not possible to create a stress range based on comparison between maximum stress ranges or between minimum stress ranges. Here in the example the stress range will be determined by (a) the maximum principle stress (+ay) – (b) minimum stress range (-ay)

For a typical type C-tank installation on board a ship the dynamic stresses are normally dominated by ship accelerations. The accelerations creating inertia loading on the structure can be based on accelerations determined at the center of gravity of the liquid in the tanks.

For simplification the acceleration can be divided in accelerations in the three directions (a_x , a_y and a_z).

8. Applied probability levels of accelerations

In simplified fatigue assessments where a representative stress level is applied to determine the fatigue strength utilization a stress level at a probability level of 10^{-4} or 10^{-2} is usually applied. This is the probability level that is considered to contribute most to the fatigue damage. Practically, when a long-term distribution curve (Weibull distribution) is fitted to a stress response it is most important that the curve-fitting is correct for these probability levels.

However, when the Weibull parameters are defined the selected probability level do not influence the results unless there is a non-linear effect on stress response depending on probability level of the loads. Often a shape factor of 1.0 is selected to represent the long-term distribution. The relation between probability level and stress response is then as follows stress at 10^{-8} probability level will be reduced with a factor of two at the probability level of 10^{-4} . The fatigue response can be determined based on the same accelerations as utilized in ULS if the structural model is linear, I.e at 10^{-8} probability level.

If contact elements at supports are applied (non-linear behavior), accelerations at a probability of 10^{-4} should normally be applied.

9. Load cases for fatigue assessment

For fatigue evaluations the dynamic stress range at the local hotspot is to be determined. As the stresses for a type C tank often is non-linear due to contact elements and the stresses often are affected by deflections from static loads and thermal effects, the load cases will need to include all these effects to be correct.

However, the static stresses will need to be deducted or filtered away to extract the dynamic stress range. Load cases (6 load cases below) shall include all static load components including thermal loads in addition to the dynamic load component.

Following 6 load cases will be required to determine the high cycle fatigue utilization. Accelerations are determined at 10^{-4} probability level, at the center of gravity of the tank with x direction parallel to the rotation axis of the tank (longitudinal), y direction transverse of the tank, parallel to the horizontal, z direction vertical and normal to the horizontal plane.

- 1) $+a_x$ (longitudinal acceleration)
- 2) $-a_x$ (longitudinal acceleration)
- 3) $+a_y$ (transverse acceleration)
- 4) $-a_y$ (transverse acceleration)
- 5) $+a_z$ (vertical acceleration)
- 6) $-a_z$ (vertical acceleration)

10. Determination of stress range from load cases

From the 6 load cases, defined in 2.2.5, the stress ranges are determined as follows:

$$\Delta\sigma_x = \sigma(+x) - \sigma(-x)$$

where:

$\Delta\sigma_x$ = Stress range for accelerations in longitudinal direction

$\sigma(+x)$ = Principal stress amplitude from load case 1

$\sigma(-x)$ = Principal stress amplitude from load case 2

$$\Delta\sigma_y = \sigma(+y) - \sigma(-y)$$

where:

$\Delta\sigma_y$ = Stress range for accelerations in transverse direction

$\sigma(+y)$ = Principal stress amplitude from load case 3

$\sigma(-y)$ = Principal stress amplitude from load case 4

$$\Delta\sigma_z = \sigma(+z) - \sigma(-z)$$

where:

$\Delta\sigma_z$ = Stress range for accelerations in vertical direction

$\sigma(+z)$ = Principal stress amplitude from load case 5,

$\sigma(-z)$ = Principal stress amplitude taken from load case 6

The combined stress range determined based on all three load directions can be calculated based on a root square summation based on the assumption that each stress component is statistically independent of the other load components. This is considered a realistic assumption especially at the probability level of 10⁻⁴. The combined stress range can accordingly be determined as:

$$\Delta\sigma = \sqrt{\Delta\sigma_x^2 + \Delta\sigma_y^2 + \Delta\sigma_z^2}$$

The stress range ($\Delta\sigma$) can be used with recognized SN curves and application of Miner-Palmgren fatigue calculations to determine the fatigue damage. The fatigue utilization shall not exceed 0.1 (See 2.2.1) to meet the fatigue strength criteria.

11. EXTRACTION OF STRESSES FROM FEM ANALYSIS

The stresses, at the location where the fatigue strength is evaluated, shall first be extrapolated to the surface of the plate and then to the hot spot. There are several extrapolation techniques used, including linear extrapolation.

The extrapolation techniques should be used with care and the local stress variations and the deflections of the highly loaded areas should be studied. The extrapolation techniques can be non-conservative for some applications, with large local stress variations.

The extraction of principal stress range should be selected within $\pm 45^\circ$ of the normal to the weld toe should be used for the analysis as illustrated in Figure 4. Here it is assumed here that the crack is growing parallel to the weld.

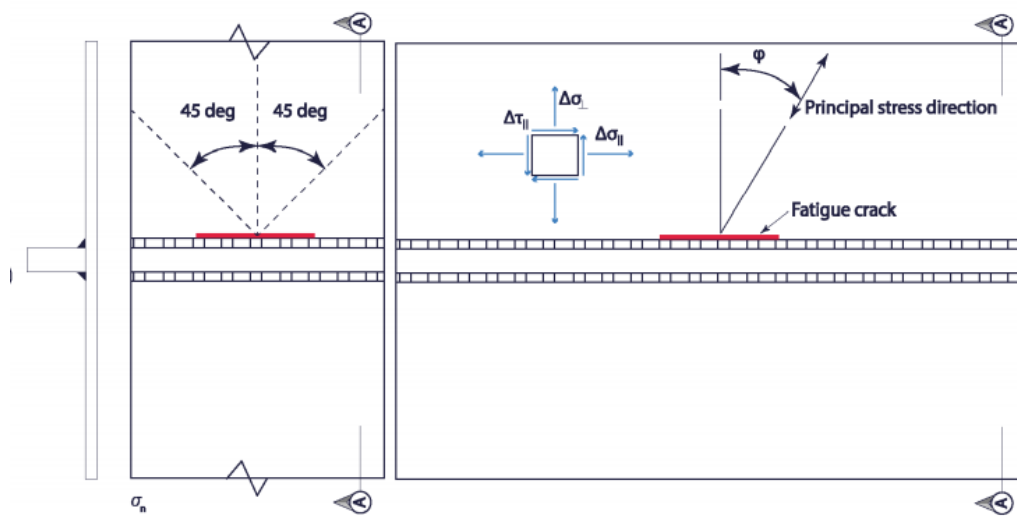

Figure 4 The principal stresses used to determine the stress range shall be selected in the range $\pm 45^\circ$ to the normal of the assumed fatigue crack development direction

12. Example of locations where high dynamic stresses may be expected

For cylindrical tanks large dynamic stresses are expected at the supports and at support frames as shown in Figure 5.

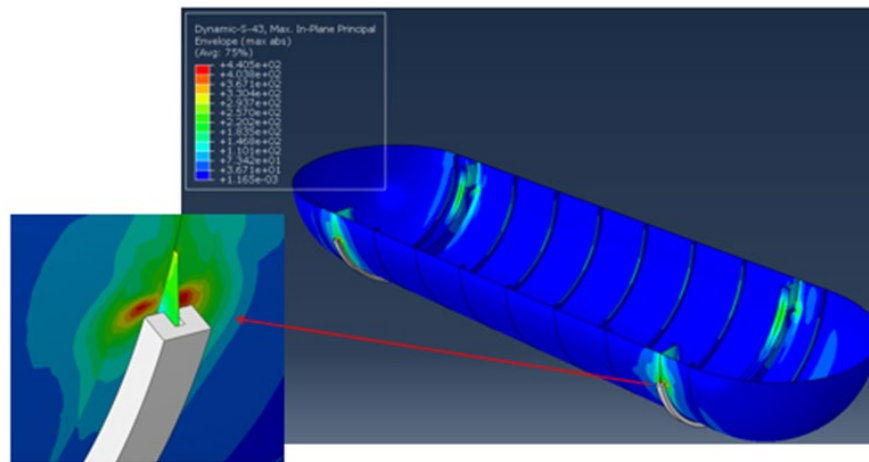

Figure 5 High dynamic stresses at the saddle-horn may be expected for transverse and vertical accelerations

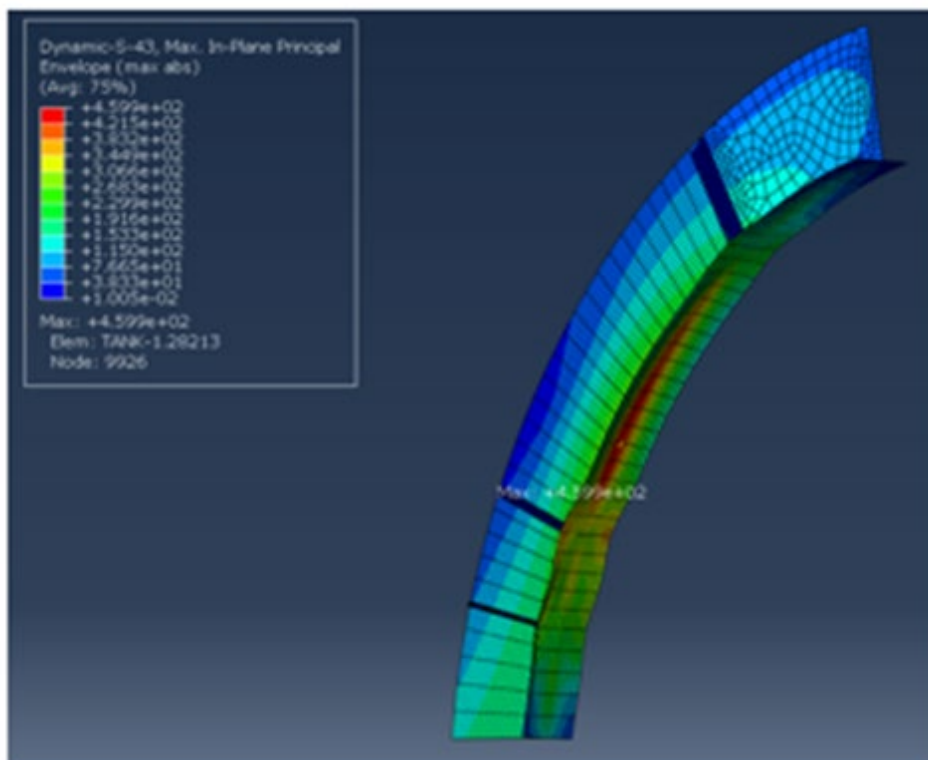

Figure 6 High dynamic stresses in the support ring frames are common due to transverse and vertical accelerations. The figure shows the deflections and it can be seen that the stresses are due to transverse bending due to the curvature of the flange

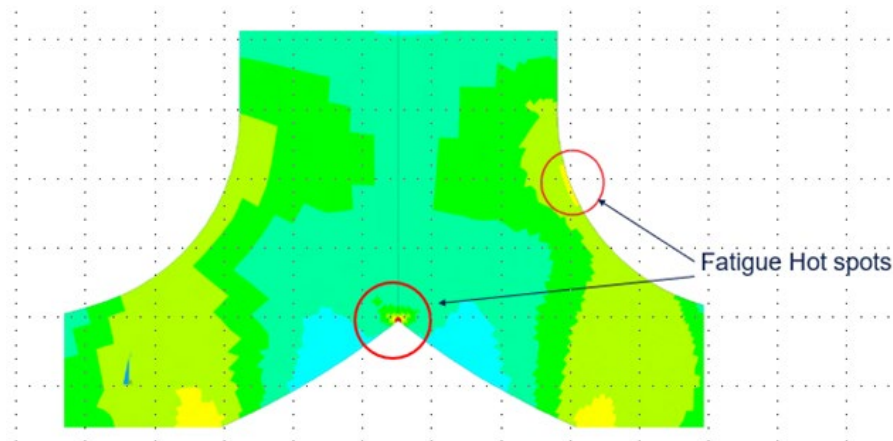

Figure 7 Possible locations of fatigue hot spots in a bi-lobe tank : at Y-joint and at the support frames where the radius is relatively small. Other locations can be at the ending of support blocks to the saddle (upper and lower saddle horns)

13. Example of fatigue calculations based on local fine meshed model in 20 node solid elements

Here is an example, on how to calculate the fatigue damage at a local hotspot, at the location where the tank is resting on the top of the saddle support. The tank shell including the doubler plate is modelled by 20-node shell elements and the solid model is connected to the rest of the tank modelled with shell elements outside the high stressed area.

The doubler plate is only connected to the tank through the welds. The surfaces between the doubler plate and the tank is modelled by contact elements. No friction applied between the two plates as the friction force may be faulty transferred depending on the FE program applied. In Figure 8 the evaluated hot spot is illustrated.

The fatigue due to high stresses in the hoop direction (a) is evaluated and the fatigue utilisation due to transverse loading at the weld of the doubler plate is also considered (b), see Figure 8.

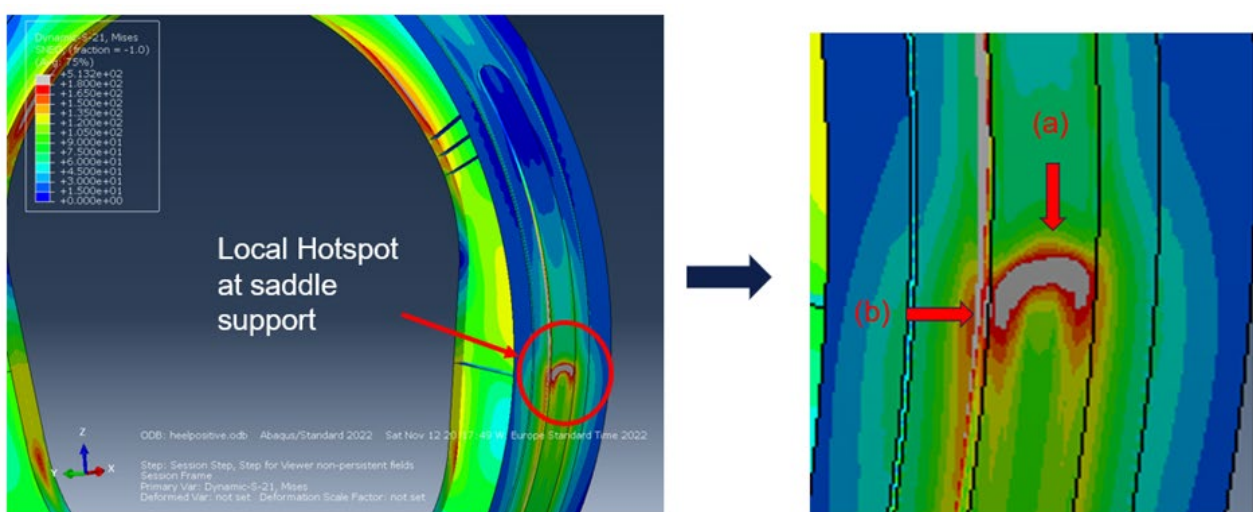

Figure 8 The fatigue loading where the tank is in contact with the top of the saddle is evaluated

Calculation of hot spot stress location (b)

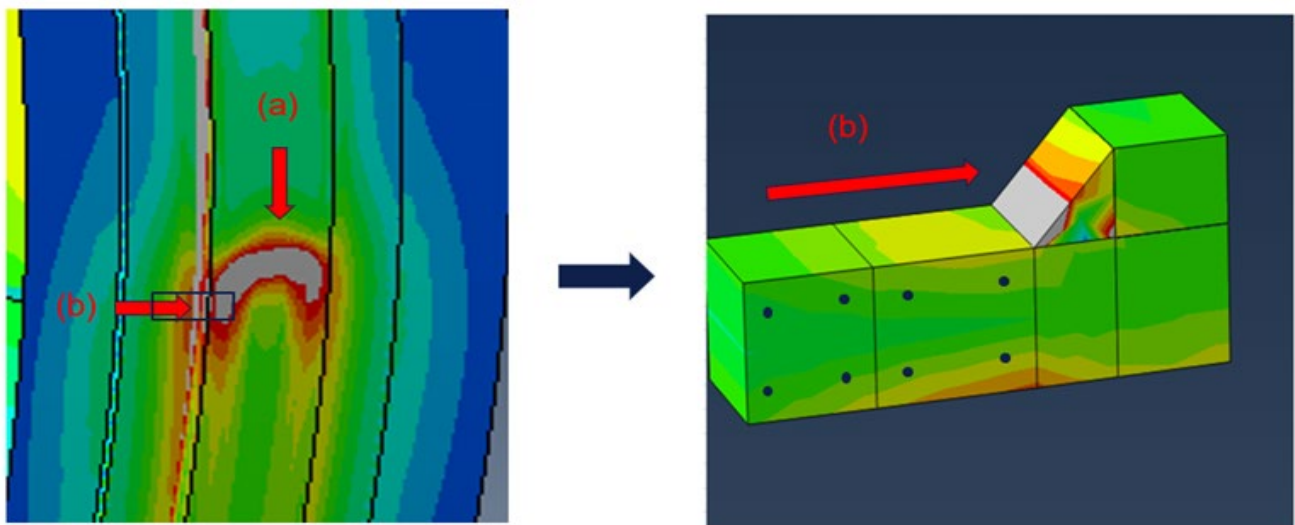

Figure 9 Only the most highly stresses elements of the connection between the tank shell and doubler plate are illustrated in the example.

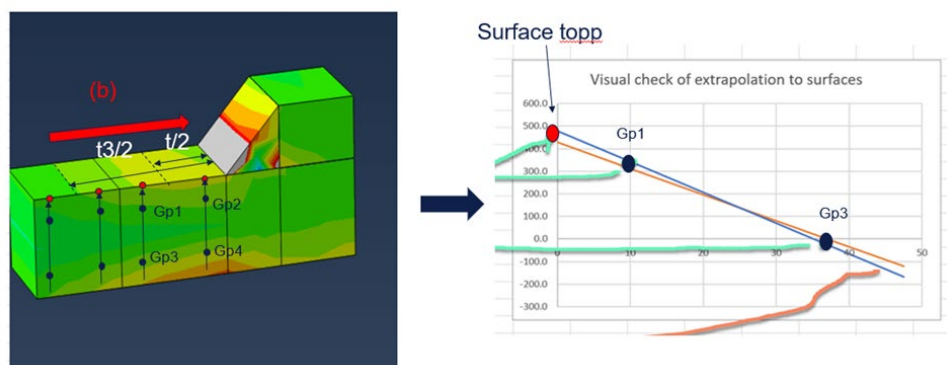

Figure 10 Extrapolation of stress to plate surface. The plate thickness in the example is 50 mm thick and stresses are presented at Gauss points (black dots) at location $(1 - 1/\sqrt{3}) \cdot t/2$ below surface for the applied element type. Manual extrapolation to surface is required (red dots)

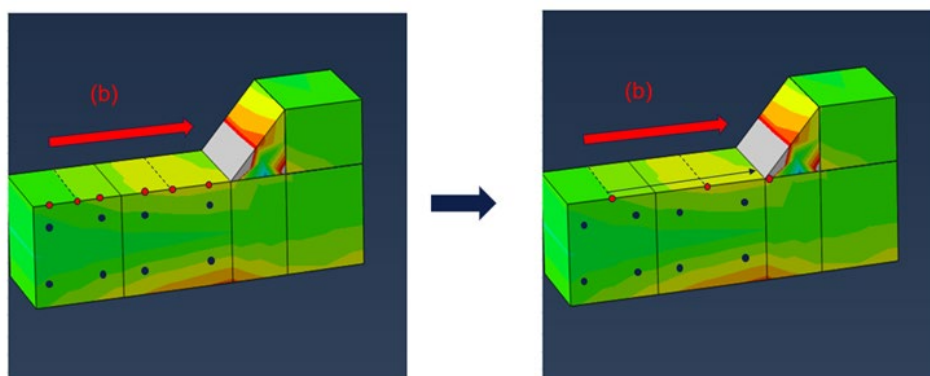

Figure 11 The extrapolation method is to be based on a linear extrapolation of stress based on the distance $1/2t$ and $3/2t$ from the hotspot. The determined surface stresses based on the Gaussian stress need to be adjusted to the $t/2$ and the $3/2t$ location before extrapolation to the hot spot.

To determine the hotspot stress following calculation steps are required:

- 1) Run the tank for the 6 load cases where all static load components are included plus the dynamic accelerations as follows.
 - a. Load case LC1: All static loads plus acceleration for acceleration in x-direction
 - b. Load case LC2: All static loads plus acceleration in negative x-direction
 - c. Load case LC3: All static loads plus acceleration for acceleration in y-direction
 - d. Load case LC4: All static loads plus acceleration in negative y-direction
 - e. Load case LC5: All static loads plus acceleration for acceleration in z-direction
 - f. Load case LC6: All static loads plus acceleration in negative z-direction
- 2) For each load case LC1 – LC6 the surface stress at the distance $0.5t$ and $3/4t$ from the hot spot need to be determined. The stress components normal to the weld shall be defined. (See Figure 10 and Figure 11)
 - a. The gauss stresses are normally located $(1-1/\sqrt{3})t/2$ below the surface and therefore the surface stress will have to be extrapolated based on the Gauss stress (see Figure 10)
 - b. As the extrapolation method to hot spots is based on linear extrapolation of stress based on distance $1/2t$ and $3/2t$, the determined surface stresses based on Gaussian stress, need to be extrapolated to the $t/2$ and the $3/2t$ location
 - c. The hot spot stress can now be linearly extrapolated based on the surface stress $t/2$ and the $3/2t$ from the hot spot location (see Figure 11)
- 3) The stress range based each of the three acceleration directions can now be made as the difference between stresses for the 6 load cases
 - a. Stress range for acceleration in x-direction ($\Delta\sigma_x$) is the difference between the stresses in LC1 and LC2. Note that it is important to define the stresses in LC1 and LC2 with sign to determine the stress range correctly.
 - b. Stress range for acceleration in y-direction ($\Delta\sigma_y$) is the difference between the stresses in LC3 and LC4. Note that it is important to define the stresses in LC3 and LC4 with sign to determine the stress range correctly.
 - c. Stress range for acceleration in y-direction ($\Delta\sigma_z$) is the difference between the stresses in LC5 and LC6. Note that it is important to define the stresses in LC5 and LC6 with sign to determine the stress range correctly.
- 4) The stress range for the three accelerations ($\Delta\sigma_x$), ($\Delta\sigma_y$) and ($\Delta\sigma_z$) are now determined and the combined stress range ($\Delta\sigma$) is to be calculated according to the square root summation (See Table 1):

$$\Delta\sigma = \sqrt{\Delta\sigma_x^2 + \Delta\sigma_y^2 + \Delta\sigma_z^2}$$

- 5) The fatigue damage can be calculated based on the fatigue strength capacity of a D-curve (or a FAT 90 curve) where $m=3$, $\log(k_2) = 12.164$ (see table xy). The acceptable Damage is $D < 0.1$ and accordingly the determined fatigue damage based on the stresses in this example is not acceptable. (It can be noted that even though the total stresses apparently are low the fatigue stress range is by far too high.)

Table 1 The calculated stress range on top of the elements at the fillet weld is 212 MPa

Load case	Element no	Gauss Point no				Extrapolation direction				bottom	topp	topp	bottom	topp	bottom	Topp	bottom
		Gauss point 1	Gauss point 2	Gauss point 3	Gauss point 4	surface bunn 1,3	Surface bunn 2,4	Surface topp 1,3	Surface topp 2,4								
LC1	e1	24	70	-24	-30	-48	-80	48	120	-64	84	98,625	-29,875	3,25	26,25	211,821	138,752
	e2	30	90	-10	-5	-30	-52,5	50	137,5	-41,25	93,75						
LC2	e1	22	90	10	15	4	-22,5	28	127,5	-9,25	77,75	95,375	-56,125				
	e2	23	91	-9	-7	-25	-56	39	140	-40,5	89,5						
LC3	e1	60	150	30	40	15	-15	75	205	0	140	269,375	-88,125	191,25	-33,75		
	e2	90	220	10	15	-30	-87,5	130	322,5	-58,75	226,25						
LC4	e1	-20	50	0	40	10	35	-30	95	22,5	12,5	78,125	-54,375				
	e2	-10	80	-10	-5	-10	-47,5	-10	122,5	-28,75	56,25						
LC5	e1	150	170	200	170	225	170	125	170	197,5	147,5	96,875	-100,625	-91	-132		
	e2	40	70	20	15	10	-12,5	50	97,5	-1,25	73,75						
LC6	e1	150	200	150	210	150	215	150	195	182,5	172,5	127,875	31,375				
	e2	100	155	99	95	98,5	65	100,5	185	81,75	142,75						

The calculations assuming that all stress concentration factors are covered by the results in the FE analysis and a D-curve or FAT 90 curve can be applied the fatigue damage based on 212 MPa stress range will be equal to 0,35 which is significantly higher than the allowable 0,1. Accordingly the design will likely need to be redesigned.

Recommendation No.175 "SEEMP/CII Implementation Guidelines"

Summary

IACS developed the SEEMP/CII Implementation Guidelines containing a set of recommendations for supporting the implementation of IMO SEEMP/CII framework (MARPOL Annex VI regulations and supporting guidelines).

Part A. Revision History

Version no.	Approval date	Implementation date when applicable
New (Apr 2023)	25 April 2023	-

- **New (Apr 2023)**

1 Origin of Change:

- Other - Environmental Panel Task no. PT PE05/2022(PE22007, 21213_)

2 Main Reason for Change:

None

3 List of non-IACS Member classification societies contributing or participating in IACS Working Group:

None

4 History of Decisions Made:

MARPOL Annex VI in MEPC 76 session of IMO and includes SEEMP, annual operational carbon intensity indicator (CII) and CII rating along with relevant guidelines. The Technical Guidelines on Carbon Intensity Reduction to develop SEEMP guidelines, SEEMP Verification guidelines and guidelines on CII correction factors were adopted in MEPC 76 and MEPC 78. Environmental Panel received several queries regarding the implementation of the SEEMP/CII requirements. After consideration, Environmental Panel recognized the existence of ambiguities or potentially disruptive issues that need to be further considered and GPG agreed to establish PT PE 05, to address the implementation issues associated with SEEMP/CII and develop an IACS Recommendation containing SEEMP/CII implementation guidelines.

Environmental Panel conducted a final review of the draft submitted by PT PE 05 and finally agree on the final draft.

5 Other Resolutions Changes:

None

6 Any hinderance to MASS, including any other new technologies:

None

7 Dates:

Original Proposal	: 10 April 2023	(Made by: Environmental Panel)
Panel Approval	: 16 April 2023	(Ref: 23003_PEf)
GPG Approval	: 25 April 2023	(Ref: 23003_IGi)

Part B. Technical Background

List of Technical Background (TB) documents for Rec 175:

Annex 1. **TB for New (Apr 2023)**

See separate TB document in Annex 1.

Technical Background (TB) document for Recommendation No. 175 (New Apr 2023)

1. Scope and objectives

These implementation guidelines have been developed by IACS in response to the following MEPC Resolutions relating to SEEMP and CII framework.

1. Resolution MEPC.346 (78) - 2022 Guidelines for the development of a Ship Energy Efficiency Plan (SEEMP);
2. Resolution MEPC.347 (78) - Guidelines for the verification and company audits by the Administration of Part III of the Ship Energy Efficiency Plan (SEEMP);
3. Resolution MEPC.352 (78) - 2022 Guidelines on Operational Carbon Intensity Indicators and the Calculation Methods (CII Guidelines, G1);
4. Resolution MEPC.353 (78) - 2022 Guidelines on the Reference Lines for Use with Operational Carbon Intensity Indicators (CII Reference Lines Guidelines, G2);
5. Resolution MEPC.338 (76) - 2021 Guidelines on the Operational Carbon Intensity Reduction Factors relative to Reference Lines (CII Reduction Factors Guidelines, G3);
6. Resolution MEPC.354 (78) - 2022 Guidelines on the Operational Carbon Intensity Rating of Ships (CII Rating Guidelines, G4);
7. Resolution MEPC.355 (78) - 2022 Interim Guidelines on Correction Factors and Voyage Adjustments for CII Calculations (CII Guidelines, G5).

These resolutions make reference to the development of SEEMP Part III, verification of SEEMP Part III, company audits, calculation of attained and required annual operational CII values and CII correction factors. The project team was set and developed these guidelines which aim at providing guidance on SEEMP and CII implementation level.

The document may be updated whenever new issues are brought to the attention of IACS.

2. Engineering background for technical basis and rationale

Implementation guidelines have been developed based on the set of available texts in MEPC resolutions and relevant regulations of MARPOL Annex VI.

2a. Specification of the data utilised in the development/revision of the proposed IACS Resolution, if any

None

3. Source/derivation of the proposed IACS Resolution

Revised MARPOL Annex VI (Resolution MEPC.328(76)) and MEPC resolutions listed paragraph 1 above.

4. Summary of Changes intended for the revised Resolution:

None

5. Points of discussions or possible discussions

None

6. Attachments if any

None

Recommendation No.176

“Measurement of Underwater Radiated Noise”

Summary

This new Recommendation aims at harmonising the methods of measurement of underwater radiated noise (URN) from ships and provides a consistent analysis/post processing means and reporting standard.

Part A. Revision History

Version no.	Approval date	Implementation date when applicable
New (Sep 2023)	15 September 2023	-

- **New (Sep 2023)**

1 Origin of Change:

Not applicable (new Recommendation).

2 Main Reason for Change:

Not applicable (new Recommendation).

3 List of non-IACS Member classification societies contributing or participating in IACS Working Group:

None.

4 History of Decisions Made:

There is increasing interest in reducing the underwater noise produced by ships. The unique existing ISO standards are inconsistently applied. On-going developments are conducted by ISO.

Industry, through ICS, has set up a working group in which IACS has participated and which has stressed the need to work with ISO in order to ensure an agreement on terminology, metrics and other standards related to URN measurements.

In this regard, IACS considered seen as applying requirements consistently referring to up-to-date standards. Consequently, IACS has established a PT to establish the unified measurement of underwater radiated noise.

As a result of the PT, the draft UR was submitted.

However, one member commented that several projects related to underwater noise are ongoing. It was suggested to wait for the results of these projects, and IACS

would get great benefit from this outcome. As a result of the discussion, GPG concluded the draft UR would be published as IACS Recommendations in the interim.

Finally, the draft UR has been published as an IACS Recommendation. This recommendation can be published as IACS UR after further discussion in the future.

5 Other Resolutions Changes:

None.

6 Any hinderance to MASS, including any other new technologies:

None.

7 Dates:

Original Proposal:	03 March 2023	(Made by: IACS PT PS43)
Panel Approval:	25 August 2023	(Ref: PS20003gISs)
GPG Approval:	15 September 2023	(Ref: 20143_IGt)

Part B. Technical Background

List of Technical Background (TB) documents for Rec 176:

Annex 1. **TB for New (Sep 2023)**

See separate TB document in Annex 1.

Technical Background (TB) document for Recommendation No. 176 on Measurement of Underwater Radiated Noise

1. Scope and objectives

The proposed Recommendation aims at harmonising the methods of measurement of underwater radiated noise (URN) from ships and provide a consistent analysis/post processing means and reporting standard.

2. Engineering background for technical basis and rationale

At the day of the current Recommendation, 7 IACS members (ABS, BV, CCS, DNV, KR, LR, RINA) had issued a URN-related class notation, including measurement procedure as well as limits to comply to.

This base of documents has been the major elements on which the PT has conducted its harmonisation work.

In addition, the ISO available standards on underwater acoustics have been considered. With that respect, it has been noted that the measurement procedures within shallow water conditions were not and still are not at this day issued. Therefore, additional exchanges have been conducted with ISO representatives and especially with ISO17208-3 working group.

In completion, dedicated participations to dedicated workshops on the measurement harmonization issue have been made. In particular, the PT manager as well as several PT members and additional class representatives have joined the 3 workshops and other various meetings organised by the Port of Vancouver within its "Improved alignment of quiet ship notations" initiative.

3. Source/derivation of the proposed IACS Recommendation

The Recommendation includes proposal of measurement and post-processing procedure to be considered within shallow waters which is likely to need further update pending on the future issuance of ISO17208-3 addressing this subject.

4. Summary of Changes intended for the revised Recommendation:

Not applicable (new Recommendation).

5. Points of discussions or possible discussions

The starting point of this harmonisation work has been the variability in used metrics as well as differences in the procedures and post-processing themselves, among the 7 class rules available on the topic as per today.

6. Attachments if any

None.

Rec.177 “Shipbuilding and Remedial Quality Standard for Machinery Piping Systems”

Summary

This Rec.177 provides guidance on shipbuilding quality standards for the machinery piping systems during ship new construction phase and the remedial standard where the quality standard is not met. This Rec.177 is a new development of recommendation.

Part A. Revision History

Version no.	Approval date	Implementation date when applicable
New (Dec 2023)	22 December 2023	-

- **New (Dec 2023)**

This Rec.177 is a new development of recommendation.

1 Origin of Change:

- Other (proposed by IACS Liaison to ISO/TC8 (CCS GPG Member))

2 Main Reason for Change:

Noted that the previous Rec.47 contents only hull structure and the shipbuilding industry is in need of quality standards for machinery piping systems, IACS initiated a new task for the development of a new recommendation Rec.177 on Shipbuilding Quality Standard for Machinery Piping Systems, to improve the quality standards in terms of fabrication, installation, commissioning and function tests of machinery piping systems onboard ship.

3 List of non-IACS Member classification societies contributing or participating in IACS Working Group:

None

4 History of Decisions Made:

1. As proposed by IACS Liaison to ISO/TC8 (38th plenary meeting 2019) and noted that the industry is in need of quality standards for machinery piping systems, IACS discussed at GPG87(Draft GPG87 FUA32) and considered it's necessary to respond to industry's demands in a timely manner, by expanding quality standards in IACS Rec.47 to include machinery piping systems.

2. The form A and Form 1 were approved originally on 23 October 2020 (Reference no.: 19221_IGe), and the development work was initiated. Only machinery piping system within the work in charge of newbuilding shipyards is included within the TOR of Rec.177, Machinery and repair quality requirement are all excluded.

Work items comprise of:

- Discuss and describe General requirement for shipyard's work, Qualification requirements for personnel and procedural documents and General quality requirements for marine products.
- Define terminology in relation with machinery pipings (class) and limit the applicable range of Rec.177 within the work in charge of newbuilding shipyards. Identify critical quality control parameters and specify relative construction accuracy for newbuilding ships on fabrication, installation and test, in Machinery piping systems.

Identify critical machinery piping systems together applicable piping material standards and with relevant fabrication methods and processes (e.g. corrosion protection) applicable, and describe quality requirements: at shipyard workshop stage, on pipe fabrication, assembling, welding, seam quality, NDE, hydraulic test, surface anticorrosion treatment; onboard stage, on piping erection, tightness test, flushing and function test of piping systems.

- Submit draft to Machinery Panel to review, consider Machinery Panel comments and update draft as necessary, and then submit to GPG for pre-approval, thereafter seek for opinions of stakeholders (shipbuilding industry etc.) with appropriate way (by GPG through communication mechanism between IACS and Industry, if possible), then final revise and approval.

Meanwhile, three stages were divided:

- **Stage 1: sketch frame**

Discuss and define the scope of this standard and its applicability, list involved piping, sketch the draft frame

- **Stage 2: detail content and develop draft**

Literature study, collect relevant quality standards, IACS resolutions/recommendations and class societies' rules, and analysis purposefully. List identified pipe materials, components, fittings, joints, identify critical quality control parameters, NDE methods, and to detail outline of content.

Seek for commonly acceptable unified criteria for specified detail critical quality control parameters and relative margin range.

Investigate industry practices through member societies, update criteria with feedback, and develop a first draft and propose.

- **Stage 3: final review and revise**

Industry review, and revise with industrial comments, propose to MP and GPG for final approval, keeping in mind that acceptable quality standard should always be in accordance with shipyard industry's current actual production capacity.

3. The form A and Form 1 were re-approved on 07 December 2020(Reference no. : 19221_IGg), and revised on 16 Feb 2021 (Ref: 20181aIGd), 18 Nov 2021 (Ref: 21171_IGb), 23 Aug 2022 (Ref: 19221_IGj).

4. The draft of stage 1 was proposed to MP on 31 Dec., 2020, the draft of stage 3 was proposed to MP on 31 Dec., 2022. The final clean version draft was proposed to MP on 21 May 2023. Industry opinions were heard through each MP Members. Document has been reviewed by EG/M&W and Survey Panel.

5 Other Resolutions Changes:

As a new recommendation, this Rec.177 is to focus on shipbuilding quality standard for machinery piping systems, however the previous Rec.47 contents only hull structure, then the title of the previous Rec.47 might to be changed correspondingly.

6 Any hinderance to MASS, including any other new technologies:

None.

7 Dates:

Original Proposal	: 31 December 2022	(Made by: PT PM46/PM19948IMa)
Panel Approval	: 05 September 2023	(Ref: 19948_IMzj)
GPG Approval	: 22 December 2023	(Ref: 19221_IGt)

Part B. Technical Background

List of Technical Background (TB) documents for Rec.177: Shipbuilding Quality Standard for Machinery Piping Systems

Annex 1. **TB for New (Dec 2023)**

See separate TB document in Annex 1.

Technical Background (TB) document for Rec.177 (New Dec 2023)

1. Scope and objectives

As the previous Rec.47 contents only hull structure and the shipbuilding industry is in need of quality standards for machinery piping systems, so it's necessary to develop a new recommendation Rec.177 on Shipbuilding Quality Standard for Machinery Piping Systems, to improve the quality standards in terms of fabrication, installation of machinery piping systems onboard ship.

Only machinery piping system within the work in charge of newbuilding shipyards is included within the TOR of Rec.177, Machinery and repair quality requirement are all excluded.

The standard does not apply to the new construction of:

- (1) Piping for ship structure purpose,
- (2) Integrated or built-in pipes within the range of engine, skid, equipment or device,
- (3) Piping systems for special purpose which might to be needed to imply with special requirements, e.g. cargo piping, process piping,
- (4) Submarine pipeline system, mud piping for dredging etc. , or
- (5) Piping for nuclear power plant.

The standard does not cover the quality requirements for product manufacture of piping equipment and piping components, regardless whether they are made inside or outside of the shipyard, for example:

- (1) Pipes and flexible hose assemblies,
- (2) Piping fittings, e.g. flanges, forged elbows, bellows, mechanical joints,
- (3) Piping components, e.g. valves, gaskets etc.,
- (4) Piping equipment, e.g. pumps, pressure vessels

2. Engineering background for technical basis and rationale

The following quality factors for machinery piping systems are involved during shipbuilding:

Material, strength, shaping, welding, anti-corrosion, assembly, erection stress, operating stress (pressure pulse, or thermal expansion), cleanliness, vibration, tightness etc.

Correspondingly, the following quality control measurements are taken into account:

- Raw Material, including surface conditions, plug scores, dent and remedial of defects
- Workshop Fabrication, Cutting, Bending, Edge preparation and assembly, Preheating and Post heat treatment for welding, Weld surface quality, Weld internal quality and remedy,
- Installation onboard quality including Piping support spacing, Gap, and flushing.

General requirements for piping systems new construction and Qualification of personnel and procedures, are essentially involved.

2a. Specification of the data utilised in the development/revision of the proposed IACS Resolution, if any

The quality requirements are mainly originated from industry experience, PT Members' knowledge, and the following documents are referenced:

- GB/T 34000-2016 China shipbuilding quality standard
- IACS Recommendation No.47 Part A Shipbuilding and Remedial Quality Standard for New Construction
- IACS UR P2 Rules for piping design, construction and testing
- GB/T 9711-2017 China national standard Petroleum and natural gas industries- Steel pipe for pipeline transportation systems, **modified** (as per ISO/IEC Guide 21-1:2005)" from **ISO 3183:2012** Petroleum and natural gas industries - Steel pipe for pipeline transportation systems.

3. Source/derivation of the proposed IACS Resolution

Rec.177 content	Reference
1.2~1.5	Rec.47 Part A 1.2~1.5
3.1~3.3	Rec.47 Part A 2.1~2.3
4.1.1,4.3	Rec.47 Part A 3.1.1, 3.3
5.3	Annex C of GB/T 9711-2017
6,7	GB/T 34000-2016 5.3.4

4. Summary of Changes intended for the revised Resolution:

As a newly proposed Rec.177, this is the original version of this Rec.

5. Points of discussions or possible discussions

Although anti-vibration, anti-corrosion treatments and function of piping systems are important aspects, their requirements specifications are unable to reach a unified value, for which reason, relevant contents are not included in this Rec.177.

As no leak is permitted, so no requirements provided for tightness.

Requirements for alternative fuel piping will be addressed in a future revision of Rec.

Draft of REC.177 has been reviewed by ASEF (Active Shipbuilding Experts' Federation) with following suggestion.

"The general rib or longitudinal structure spacing is 800mm, the two rib positions are 1600mm. If the two pipe supports are welded to the structure, the spacing is exactly 1600mm. So, it would be better if the text in page 32 can be adjusted."

MP found that the limit is 1.2 times of L1(standard) which will be maximum distance of 1800mm while distance proposed by ASEF (Active Shipbuilding Experts' Federation) as 1600mm is with the range and limit.

However, MP added note to following paragraph 7.2 to respect and incorporate ASEF suggestion as follow;

“Note: The spacing might be adjusted flexibly within a certain reasonable range considering of the onboard layout (e.g., frame space of hull structure) to facilitate construction, provided the provisions of 7.2.1-7.2.3 above have been fulfilled.”

Draft of REC.177 has been reviewed by SuP and EG Material&Welding without comments.

6. Attachments if any

None.

Recommendation No. 178

“Earthing Guidelines for Maritime Industry”

Summary

Development of Earthing Guidelines for Maritime Industry. IACS Project Team PT PM47/2021 to identify the best practices for protective earthing for steel, aluminium, mobile or fixed offshore Units and non-metallic vessels.

Part A. Revision History

Version no.	Approval date	Implementation date when applicable
New (Dec 2023)	04 December 2023	-

• New (Dec 2023)

1 Origin of Change:

- Other - *Machinery* Panel Task no. **PT PM47/2021 (PM17401)**

2 Main Reason for Change:

Not applicable, new document

3 List of non-IACS Member classification societies contributing or participating in IACS Working Group:

None

4 History of Decisions Made:

As per discussions and subsequent agreement during September 2020, Machinery Panel suggested to form a PT in order to develop guidelines for earthing on board ships, and mobile offshore drilling units (MODU) essential for a safe and reliable electrical system design, construction, testing, installation and further operation.

5 Other Resolutions Changes:

None

6 Any hinderance to MASS, including any other new technologies:

None

7 Dates:

Original Proposal:

19 October 2020

Made by: Machinery Panel

Panel Approval:
GPG Approval:

03 November 2023
04 December 2023

(Ref:PM17401_IMzg)
(Ref: 19024_IGg)

Part B. Technical Background

List of Technical Background (TB) documents for Rec 178:

Annex 1. **TB for New (Dec 2023)**

See separate TB document in Annex 1.

Technical Background (TB) document for Rec. 178 (New Dec 2023)

1. Scope and objectives

The scope of present documents is to identify the best practices for protective earthing for steel, aluminium, mobile or fixed offshore Units and non-metallic vessels. The guidelines are structured to give an overview of System earthing philosophy & Earthing for Lightning protection in Maritime installations. The guidelines also give a brief overview of hazardous area earthing.

Improper earthing methodology has the potential to bring disastrous results from both an operational as well as a safety standpoint. The recommendations are aimed to identify best practises for ship and offshore installations. The recommendations also will address specific earthing, where required for cyber systems.

2. Engineering background for technical basis and rationale

Implementation guidelines have been developed which in the opinion of IACS members required clarity in Earthing Methodology for following areas/systems:

- System earthing.
- Earthing for shore connections.
- Earthing and bonding.
- Earthing for non-metallic vessels crafts.
- Earthing during cargo operations.
- Earthing during oil fuel / gas fuel bunkering operations.
- Mobile offshore drilling units (MODU); and
- Special systems earthing.

The development of the IACS Guidelines is based Review of relevant standards, guidelines and IMO documents including IACS Members' classification rules with the regard to earthing requirements or other applicable regulations.

2a. Specification of the data utilised in the development/revision of the proposed IACS Resolution if any

Not applicable

3. Source/derivation of the proposed IACS Resolution

Not applicable

4. Summary of Changes intended for the revised Resolution:

Not applicable at this stage.

5. Points of discussions or possible discussions

See section 2 above. If the industry raises an issue, which has not been addressed, then this will need to be discussed.

PT prepared relevant earthing guidelines for small craft in clause 3.6 which majority in panel agreed as small craft is out of scope of IACS then relevant clause deleted.

The REC has been reviewed by **Survey Panel** for Surveyable items without comment.

6. Attachments if any

None.

Rec 179: "Recommendation for Valve Regulated Lead Acid (VRLA) Starting Batteries of Emergency Generators"

Summary

This Recommendation provides guidance for the use of engine starting batteries of the Valve Regulated Lead Acid (VRLA) type for emergency generators.

Part A. Revision History

Version no.	Approval date	Implementation date when applicable
New (Dec 2023)	20 December 2023	-

- **New (Dec 2023)**

1 Origin of Change:

None

2 Main Reason for Change:

None

3 List of non-IACS Member classification societies contributing or participating in IACS Working Group:

None

4 History of Decisions Made:

The preparation of a new Recommendation aims at the development of guidelines addressing the protection of VRLA batteries and their charging facilities to prevent excessive gas evolution, which can lead to thermal runaway.

5 Other Resolutions Changes:

None

6 Any hinderance to MASS, including any other new technologies:

None

7 Dates:

Original Proposal:	23 June 2021	(Ref: PM21701_IMa)
Panel Approval:	29 November 2023	(Ref: PM21701_IMj)

GPG Approval:

20 December 2023

(Ref: 23225_IGb)

Part B. Technical Background

List of Technical Background (TB) documents for Rec 179:

Annex 1. **TB for New (Dec 2023)**

See separate TB document in Annex 1.

Technical Background (TB) document for Rec 179 (New Dec 2023)

1. Scope and objectives

The objective of this new Recommendation is to provide guidance addressing the protection of VRLA batteries and their charging facilities in emergency generator installations, to prevent excessive gas evolution, which can lead to thermal runaway.

2. Engineering background for technical basis and rationale

Thermal runaway is a phenomenon often associated not only with lithium batteries but also with low hydrogen emission lead acid batteries, which are most often built as Valve Regulated Lead Acid (VRLA) batteries. Apparently VRLA batteries do not tolerate overcharging. VRLA batteries that are used infrequently in emergency generating set starting arrangements and are maintained with float charging for long periods of time are more at risk. This may be why this is seen primarily with emergency generator starting batteries.

Thermal runaway can be avoided in properly maintained VRLA battery systems. Still, this is a real concern for using VRLA batteries in a float charge type of installation. Float charging is used on batteries that are not used frequently. Thermal runaway can occur in VRLA batteries when the rate of internal heat generation (and gas) exceeds the rate at which the heat can be dissipated into the environment. During charging, VRLA batteries have a recombination cycle where heat is generated from the charging current on the components of the battery and from the reaction where oxygen reacts with lead and sulfuric acid to form lead sulphate and water. Most of the charging current is used to facilitate the recombination cycle. And this is where most of the heat is generated. As this continues for longer periods, the battery temperature increases, and the cells can dry out. The plastic enclosure might soften and rupture. Factors that can lead to thermal runaway or other problems:

- Float charging Voltage level too high.
- Recharge current too high (may be seen as battery temperature of 10C above ambient)
- Repetitive high-rate discharge / charge cycling (long term excessive temperature)
- High temperature operating environment
- Bad enclosure design (locker, box not allowing good ventilation.
- Battery failures (shorted cells, ground fault)

3. Source/derivation of the proposed IACS Resolution

- Proposal by a member society, which experienced issues with vessels where the starting batteries for the Emergency Diesel Generator on different vessels have exploded, specifically during Emergency Diesel Generator (EDG) starting demonstrations.
- Member societies Rules
- IEC 62485 series

4. Summary of Changes intended for the revised Resolution

None

5. Points of discussions or possible discussions

- The initial proposal for revision of UR E18 did not find support; therefore, the Panel majority agreed to the development of a Recommendation in lieu of a UR.
- On a request whether member societies (other than the initiating member) experienced similar issues, only one member advised of four reports in the past, however details are not available.
- A suggestion for checking batteries by the society's Surveyor has not been included based on members' comments that these should be rather associated with a revision of UR E18 or UR Z18.
- Regarding a query whether "enclosure" means the cabinet in which battery is stored or the external surface of the battery body, the following definitions for battery enclosure have been presented:
 - IEC 62485-1 (Safety requirements for secondary batteries and battery installations): *enclosure designed for the accommodation of batteries to protect against environmental impacts, unauthorized access of persons and hazards caused by the batteries. (included in 2.1 of the draft Rec.)*
Note: the standard has a separate definition for "battery room"
 - IEC-TS-62257-9-1 (Recommendations for renewable energy and hybrid systems for rural electrification): *7.1.6 Battery bank (battery enclosure) All batteries shall be located in an area that shall be designed to prevent access by unauthorized persons. Batteries should be installed in one of the following: a) a dedicated equipment room or battery enclosure; or... See also "D.6 Battery enclosure examples (informative)"*
 - IEC 62109-1 (Safety of power converters for use in photovoltaic power systems): *the enclosure or compartment housing the batteries shall...*
 - IEC 62093 (photovoltaic system power conversion): *Enclosure: part of the equipment which surrounds internal parts, intended to provide protection against external influences, against the spread of fire, or against access to hazards.*
- The expression "each battery" in 3.3.4 of the Recommendation has been based on the following justification offered by a member: *"battery enclosure" means not locker, compartment, or cabinet in which some batteries are put but each external surface of battery box itself which is included in minimum necessary parts for charging or discharging, such as battery cell, battery terminal used for discharge or charge and valve for ventilation etc. Especially the number of batteries for starting emergency generator diesel engine has not so much and generally two. This means that sensing the temperature of each box is not so difficult in many cases. In addition, the batteries for starting emergency generator diesel engine are generally put in not fully enclosed box but exposed rack at the emergency generator roomit seems difficult to install the temperature sensor on the rack and get temperature of battery. Therefore, it is not practical to monitor the temperature of the battery rack. Consequently enclosure means the surface of each battery box.*
- A suggestion for application of the document to all VRLA batteries and not to limit it to emergency generating installations has not received the qualified majority.
- Regarding the automatic disconnection in 3.3.4 of the Recommendation, a query was raised whether this means return to float charging. While some views agreed with the understanding for return to float charging, other members were of the

view that this is not always the case. Reference is made to section 7.6 of IEC 62845-2 "Overcharging under fault conditions": *...Electrical precautions against charger malfunction or thermal runaway shall be provided, e.g., by lowering the charge voltage below the open circuit voltage or by automatic disconnection of charging power supply. Alternatively, the ventilation should be calculated to correspond to the maximum current available from the charger.* Other comments received read as follows:

- When "automatic disconnection" operates, boost charge should not return to float charging because of safety consideration of risk of thermal runaway. Upon confirmation of lowering temperature after the disconnection, if necessary, the operator may manually return to float charging.
- the automatic disconnection will be triggered by a sudden increase of temperature and/or over-temperature of battery, which is supposed to entail relevant alarm beforehand, and that it will disconnect battery from charging facilities and in general is allowed to re-connect manually after clearing out the anomaly by ship's crew thus it doesn't necessarily mean return to float charge.
- For a question raised for the meaning of the expression "open circuit voltage" stated in section 7.6 of IEC 62845-2, the following comments have been received:
 - "Open circuit voltage" is rated supply voltage between input and output of load (for example, starting motor of E/G) for VRLA battery.
 - "Open circuit voltage" normally means the maximum voltage of the source with no load.
 - "Open circuit voltage" refers to the voltage between the two terminals (Positive and negative electrodes) of the battery, directly measured with an electric meter when the battery is in a non-working state, that is, there is no current flowing through this circuit, and this circuit is not being connected to any external load.
 - "Open circuit voltage" may be simply defined as the supply voltage of the battery.
 - the open circuit voltage is the no load voltage of secondary battery (in this case VRLA battery)
- A suggestion to address ventilation in the document as apparently there are differences between member societies' Rules has not received the required support. This can be the subject of a future work.
- The initial suggestion in para. 3.3.1 "temperature compensated chargers should be provided unless the battery is installed in a temperature-controlled space" has been replaced by "temperature compensated chargers should be provided in accordance with manufacturer's recommendation", as according to some view's ambient temperature control in emergency generator room may not be practical and feasible.

6. Attachments if any

None

Recommendation No.180

“Recommendation for conducting commissioning testing of Ballast Water Management Systems”

Summary

This recommendation provides guidance for conducting commissioning tests of the Ballast water management systems (BWMS). Revision 1 incorporates two primary modifications: first, the Rev.1 of REC.180 now aligns with Rev.1 of IMO Circular BWM.2/Circ.61, second, the size classification in Table 1 for "Single Turnover Active Fluorometry (STAF)" has been removed.

Part A. Revision History

Version no.	Approval date	Implementation date when applicable
Rev.1 (No 2024)	10 November 2024	-
New (April 2024)	19 April 2024	-

- **Rev.1 (Nov 2024)**

1 Origin of Change:

Request by non-IACS entity (*BEMA*)

Based on IMO Regulation (*rev.1 of Circular BWM.2/Circ.61*)

2 Main Reason for Change:

The new revision incorporates two primary modifications; first, the updated REC.180 now aligns with Rev.1 of IMO Circular BWM.2/Circ.61. Second, the size classification in Table 1 for "Single Turnover Active Fluorometry (STAF)" has been removed.

3 Surveyability review of UR and Auditability review of PR

NA.

4 List of non-IACS Member classification societies contributing or participating in IACS Working Group

None.

5 History of Decisions Made:

The new revision incorporates two primary modifications:

1. During the periodic review of IACS resolutions, it was noted that a new revision of one of the references listed in REC.180—specifically, IMO Circular

BWM.2/Circ.61 Rev.1—had been issued. Incorporating this updated revision of BWM.2/Circ.61 necessitated two modifications:

- Reference 4 in Section 11 (on page 12) which lists all references, has been updated to indicate the new Rev.1 of IMO Circular BWM.2/Circ.61.
 - The reference in Table 2 (on page 4) for the row dedicated to “MPN Dilution Culture + Motility for organisms $\geq 10 \mu\text{m}$ and $< 50 \mu\text{m}$ ” has also been revised accordingly.
2. BEMA, through ARIMO, raised a concern regarding the size classification for *T. punctigera*, which was originally indicated as being in the $> 50 \mu\text{m}$ size class in Table 1 of REC.180 dedicated to “Single Turnover Active Fluorometry (STAF)” (page 3). After verification, the panel confirmed that *T. punctigera* actually falls within the $\geq 10 \mu\text{m}$ - $< 50 \mu\text{m}$ size class, rather than the $> 50 \mu\text{m}$ classification as previously stated in REC.180. To avoid any further confusion, the majority of the panel agreed to amend REC.180 by removing all references to size classifications.

6 Other Resolutions Changes

None.

7 Any hinderance to MASS, including any other new technologies

None.

8 Dates:

Original Proposal	: 22 May & 12 June 2024	(Made by: Environmental Panel)
Panel Approval	: 14 June & 4 July 2024	(Ref: PE24021_, PE24024)
GPG Approval	: 10 November 2024	(Ref: 22005dIGb)

• **New (April 2024)**

1 Origin of Change:

None

2 Main Reason for Change:

None

3 Surveyability review of UR and Auditability review of PR

None

4 List of non-IACS Member classification societies contributing or participating in IACS Working Group:

None

5 History of Decisions Made:

With reference to various tasks being performed in the panel (PE19005aIEI, IEm, 20079aPEa and PEc), the Panel considered the need for developing guidance on the commissioning testing of the Ballast water management systems (BWMS)

Based on the data analysis report on the experience-building phase (EBP) associated with the Ballast Water Management (BWM) Convention submitted to MEPC 78 by the secretariat in the document - MEPC 78/4/1 and the agreement at MEPC 78 towards consideration of the finalization of the Convention Review Plan taking into account relevant implementation issues that have been submitted to MEPC, the Environmental Panel agreed to establish a PT to further consider these issues and make contributions for the uniform implementation of the BWM Convention, in particular, the task of considering the need for developing guidance on the commissioning testing of the Ballast water management systems (BWMS) including:

- Recommendations on procedures, methods and practices for commissioning testing of the BWMS (based on BWM.2/Circ.70/rev.1).
- Recommendations on procedures for handling the situation when the ambient water is not appropriate for the commissioning testing.
- Preparation of a unified reporting format to be used upon successful commissioning test.

PT submitted first draft document to the Panel 07 November 2023. Panel discussed and agreed recommendation the 2nd of February 2024. During the discussion, the panel reached consensus on the following:

- Use the term "service suppliers" instead of "service providers"
- Clarify that Table 1, referenced as point 3.4, lists examples and is not exhaustive.
- Introduce paragraph 4.4 to provide further clarification on objectives.
- Decide not to address the case of using BWT to SW/TW, as it is covered by interim guidance.
- Provide further clarification on the conditions to consider the ambient water as suitable water
- Reword paragraph 7.6 to enhance clarity.
- Reformulate paragraph 9.2 to eliminate any potential misunderstanding regarding instrument calibration requirements during tests.
- Add several references to the reference list in paragraph 11
- Consider in Annex 1 that the table indicating performance parameters to be recorded and compared with the system SDL applies for uptake and discharge
- Make several editorial modifications

Following the initial GPG review, further clarifications have been integrated concerning the recommended sampling diameter (Section 7.8 in particular Table 3).

6 Other Resolutions Changes:

None

7 Any hinderance to MASS, including any other new technologies:

None

8 Dates:

Original Proposal	: 07 November 2023	(Made by: PT PE06, Ref:PE22024a)
Panel Approval	: 02 February 2024	(Ref: PE23044_IEd)
GPG Approval	: 19 April 2024	(Ref: 24019_IGe)

Part B. Technical Background

List of Technical Background (TB) documents for Rec 180:

Annex 1. **TB for New (April 2024)**

See separate TB document in Annex 1.

Annex 2. **TB for Rev.1 (Nov 2024)**

See separate TB document in Annex 2.

Technical Background (TB) document for Rec 180 (New April 2024)

1. Scope and objectives

This Recommendation fills the need for developing guidance on the commissioning testing of the Ballast water management systems (BWMS)

The commissioning test shall demonstrate that the BWMS is working properly by verifying that the ballast water discharge is in accordance with the D-2 standard and by an assessment of self-monitoring parameters.

The purpose of these recommended guidelines is to facilitate a uniform implementation and approach to how a biological commissioning test of a Ballast Water Management Systems (BWMS) should be performed in accordance with IMO BWM.2/Circ.70/rev.1.

2. Engineering background for technical basis and rationale

According to regulation E-1.1.1 and E-1.1.5 of the BWM Convention, compliance commissioning testing shall be conducted during an initial survey and during an additional survey if this additional survey is triggered from a significant change, replacement and or repair of the BWMS. Further clarification of when a change, replacement and or repair to a BWMS is significant is further described in IMO BWM.2/Circ.66 Rev 5.

Chapter 3, 4, 6, 7, 8, 9 and 10 of this recommendation are primarily intended for Service suppliers performing commissioning testing and Class surveyors witnessing and approving the results. Chapter 5 and 6 are primarily intended for Owners and Yards in connection with preparation for commissioning testing.

These Guidelines have been developed using the best information currently available on procedures, methods, and practices for commissioning testing of BWMS.

In particular, the guidance addresses the following points:

- Recommendations on procedures, methods and practices for commissioning testing of the BWMS (based on BWM.2/Circ.70/rev.1)
- Recommendations on procedures for handling the situation when the ambient water is not appropriate for the commissioning testing.
- Preparation of a unified reporting format to be used upon successful commissioning test.

2a. Specification of the data utilised in the development/revision of the proposed IACS Resolution, if any

None.

3. Source/derivation of the proposed IACS Resolution

None.

4. Summary of Changes intended for the revised Resolution:

None.

5. Points of discussions or possible discussions

None.

6. Attachments if any

None.

Technical Background (TB) document for Rec 180 (Rev.1 Nov 2024)

1. Scope and objectives

The scope and objectives of the Revision 1 of REC.180 are the following:

- Update the reference list: Ensure the new revision reflects the updated IMO Circular BWM.2/Circ.61 Rev.1
- Clarify Size Classification for *T. punctigera*

2. Engineering background for technical basis and rationale

Revision of IMO Circular BWM.2/Circ.61: During the periodic review of IACS resolutions, it was observed that a new revision of one of the references listed in REC.180—specifically, IMO Circular BWM.2/Circ.61 Rev.1—has been issued. The integration of this updated revision necessitated the following changes:

- **Reference list Update:** Reference 4 in Section 11 “References”(page 12), which compiles all references, has been updated to reflect the new Rev.1 of IMO Circular BWM.2/Circ.61.
- **Table Modification:** The PPR references for the methodologies outlined in Table 2 (page 4) for “MPN Dilution Culture + Motility for organisms $\geq 10 \mu\text{m}$ and $< 50 \mu\text{m}$ ” have been updated as follows: The previous IMO Circular BWM.2/Circ.61 referred to “PPR 4/7 Appendix 2,” whereas Rev.1 of the same Circular now refers to “PPR 7/INF.10,” as indicated in the extracts below:

Extract from BWM.2/Circ.61: for the methodologies “MPN Dilution Culture + Motility for organisms $\geq 10 \mu\text{m}$ and $< 50 \mu\text{m}$ ” the example referred to PPR 4/7 Appendix 2

Table: Methodologies that may be used for enumerating viable organisms for type approval of BWMS

Methodologies for enumerating viable organisms	Organism size class or indicator	Assessed criteria of viability	Examples of how the methodologies are applied	Applicability to ballast water treatment technologies
FDA/CMFDA + Motility	Viable organisms $\geq 10 \mu\text{m}$ to $< 50 \mu\text{m}$	Membrane integrity, enzyme activity, motility	PPR 4/7, appendix 1; PPR 4/INF.10	Suitable for assessing treatment technologies intended to kill or remove organisms
MPN Dilution Culture + Motility	Viable organisms $\geq 10 \mu\text{m}$ to $< 50 \mu\text{m}$	Reproduction capacity, motility	PPR 4/7, appendix 2	Suitable for assessing all treatment technologies

Extract from BWM.2/Circ.61 Rev.1: for the methodologies “MPN Dilution Culture + Motility for organisms $\geq 10 \mu\text{m}$ and $< 50 \mu\text{m}$ ” the example referred to PPR 7/INF.10

Table: Methodologies that may be used for enumerating viable organisms for type approval of BWMS

Methodologies for enumerating viable organisms	Organism size class or indicator	Assessed criteria of viability	Examples of how the methodologies are applied	Applicability to ballast water treatment technologies
FDA/CMFDA + Motility	Viable organisms $\geq 10 \mu\text{m}$ to $< 50 \mu\text{m}$	Membrane integrity, enzyme activity, motility	PPR 4/7, appendix 1; PPR 4/INF.10	Suitable for assessing treatment technologies intended to kill or remove organisms
MPN Dilution Culture + Motility	Viable organisms $\geq 10 \mu\text{m}$ to $< 50 \mu\text{m}$	Reproduction capacity, motility	PPR 7/INF.10	Suitable for assessing all treatment technologies

Size Classification Adjustment for *T. punctigera*:

The panel confirmed that *T. punctigera* should be classified within the $\geq 10 \mu\text{m}$ - $< 50 \mu\text{m}$ size range, as opposed to the $> 50 \mu\text{m}$ classification previously indicated in REC.180. To mitigate potential confusion, the majority of the panel has agreed to amend REC.180 by eliminating all references to size classifications.

2a. Specification of the data utilised in the development/revision of the proposed IACS Resolution, if any

None.

3. Source/derivation of the proposed IACS Resolution

None.

4. Summary of Changes intended for the revised Resolution:

- **Reference Update:** Reference 4 in Section 11 (page 12), which compiles all references, has been updated to reflect the new Rev.1 of IMO Circular BWM.2/Circ.61.
- **Table Modification:** The reference in Table 2 (page 4) for "MPN Dilution Culture + Motility for organisms $\geq 10 \mu\text{m}$ and $< 50 \mu\text{m}$ " has been updated
- **Table Modification:** Table 1 of REC.180 dedicated to "Single Turnover Active Fluorometry (STAF)" (page 3) has been modified by removing the reference to sizes

5. Points of discussions or possible discussions

None.

6. Attachments if any

None.

Recommendation No.181

“Measurement of Underwater Radiated Noise from ships”

Summary

This recommendation aims to harmonize the methods used to measure, analyse and report underwater radiated noise from ships amongst the IACS members, ensuring consistency and comparability across different class notations.

Part A. Revision History

Version no.	Approval date	Implementation date when applicable
New (Nov 2024)	8 November 2024	-

- **New (Nov 2024)**

1 Origin:

Request by non-IACS entity (*ECHO Program research project "Proposed Alignment of Quiet Vessel Notations", ref. 20143_PSa*).

2 Main Reason:

There is increasing interest in reducing the underwater radiated noise (URN) produced by ships. The measurement of URN from ships is imperative to assess the impact of noise pollution on marine organisms, mammals and fish.

IACS agreed to consider relevant measurement methodologies and develop IACS procedures to ensure reproducible and comparable measurement results for use by IACS societies within their existing or future class notations on underwater noise.

3 Surveyability review of UR and Auditability review of PR

Not applicable.

4 List of non-IACS Member classification societies contributing or participating in IACS Working Group:

None.

5 History of Decisions Made:

See the section 2 and 5 in the Technical Background document.

6 Other Resolutions Changes:

Replaces Recommendation No. 176 (New Sep. 2023).

7 Any hinderance to MASS, including any other new technologies:

Not applicable.

8 Dates:

Original Proposal	: 20 August 2020	(Made by: Safety Panel, 20143_PSa)
Panel Approval	: 31 October 2024	(Ref: PS2003g_, PS24009_)
GPG Approval	: 08 November 2024	(Ref: 20143_IGza)

Part B. Technical Background

List of Technical Background (TB) documents for Recommendation 181:

Annex 1. **TB for New (Nov 2024)**

See separate TB document in Annex 1.

Technical Background (TB) document for Rec 181 (New Nov 2024)

1. Scope and objectives

When IACS initiated its work on URN in 2020, 7 IACS Members had issued class-related notations. Currently, 9 IACS Members have issued or are in the process of issuing class rules or guidelines on URN.

The Recommendation aims to harmonize the methods used to measure, analyse and report underwater radiated noise from ships amongst the IACS members, ensuring consistency and comparability across different class notations.

2. Engineering background for technical basis and rationale

In October 2018, MEPC 73 agreed to initiate a revision of the *Revised guidelines for the reduction of underwater radiated noise from shipping to address adverse impacts on marine life* (MEPC.1/Circ.906/Rev.1). The interest in and awareness of the impact of URN has significantly increased since IMO initiated the revision of the URN guidelines.

Regarding the measurements for UNR, the available standards were being inconsistently applied. Multiple stakeholder initiatives, including ISO, IACS, flags, industry projects have the past few years focused on identifying the most appropriate measurement methodologies.

IACS considers standards ISO 17208-1:2016 and ISO 17208-2:2019 to be established standards for measurements of underwater radiated noise in deep waters. For ships without direct access to deep waters (typically 150 m or more), such measurements may however be resource-demanding, requiring more specialized equipment and extended time at sea.

Measurements of the URN in shallow waters may, depending on the circumstances, be highly applicable and more cost-effective for some ships, for example due to limited access to deep waters for the URN measurements, reduced time at sea and alternative geometries for measuring the URN in shallow waters.

ISO has the past few years been working on the development of measurement standards for shallow waters and published the draft specification ISO/DIS 17208-3 in October 2023. The specification is still work in progress, addressing comments from stakeholders, and is expected to be published as a standard in 2025.

To make the URN measurements as available as possible to the global fleet and thereby contribute to the overall reduction of underwater noise pollution from ships, IACS has based its recommendation on the established and draft ISO standards. An aligned industry is considered paramount to making comparable URN measurements available to a larger part of the world fleet.

The new Recommendation may therefore be seen as a stepping stone towards an international aligned approach. This recommendation aims to harmonize the methods used to measure underwater radiated noise from ships amongst the IACS Members, ensuring consistency and comparability across different class notations. It is considered that if all IACS Members would apply measurement methodologies according to the ISO standards, this would be an important step towards harmonization.

Using the established and progressing ISO and industry initiatives as a basis, the new IACS Recommendation establishes:

1. common definitions and terminologies to be used for the measurements of the URN;
2. relevant measurement methodologies for the URN, taking into account the latest industry and ISO developments;
3. appropriate methodologies for post processing of data from the URN measurements;
4. parameters to be included in the URN measurement reports to support the comparison of results.

2a. Specification of the data utilised in the development/revision of the proposed IACS Resolution, if any

N/A.

3. Source/derivation of the proposed IACS Resolution

ISO 17208-1:2016 "Underwater acoustics — Quantities and procedures for description and measurement of underwater sound from ships — Part 1: Requirements for precision measurements in deep water used for comparison purposes".

ISO 17208-2:2019 "Underwater acoustics — Quantities and procedures for description and measurement of underwater sound from ships — Part 2: Determination of source levels from deep water measurements."

ISO/DIS 17208-3:2023 Underwater acoustics — Quantities and procedures for description and measurement of underwater sound from ships — Part 3: Requirements for measurements in shallow water."

ISO 18405:2017 "Underwater acoustics — Terminology."

4. Summary of Changes intended for the revised Resolution:

N/A (new)

5. Points of discussions or possible discussions

Withdrawal of IACS Rec. 176

An expert workshop on URN was held from 8 to 10 October 2024 in IACS' office in Brussels, Belgium.

The workshop started with a general discussion of the industry developments. It was recognized that measurements in deep waters were established, and no participants had any objections to basing the harmonized IACS methodologies for deep water measurements on ISO 17208-1 and -2.

The workshop further considered ISO/DIS 17208-3 as basis for possible harmonization of measurements in shallow waters. Having gone through this standard paragraph by paragraph and recorded any IACS specifications in a new document (the draft new Recommendation), it was considered that measurements in both deep and shallow waters were sufficiently covered based on ISO standards, and that there was no need for IACS to develop its own methodology or to reproduce a document containing similar methodology to that in ISO/DIS 17208-3.

It was further considered that this approach might contribute to an aligned approach amongst all international stakeholders, and that IACS by choosing to base its measurement methodologies on ISO standards therefore would contribute to increased comparability worldwide. IACS' work is not to substitute ISO work but is an empowerment of its expert work to support the maritime industry.

The workshop noted that the existing Recommendation 176 currently was misaligned with the methodologies agreed during the workshop. The Safety Panel recognized that IACS Recommendation No. 176 was issued as an interim solution while the discussions on URN measurements continued. Both the workshop participants and the Safety Panel Members were however very clear that the work of the PT was not disregarded, it had fostered important considerations, paved the way for the discussions and was a great contribution in the progress towards harmonization. However, a qualified majority of the Safety Panel Members agreed that Recommendation No. 176 was no longer needed as there was no need for IACS to develop its own methodology, and should be withdrawn.

Changing the output from UR to Rec.

The original task of PT PS43 was to develop an IACS UR for the measurements of underwater noise.

Several initiatives related to URN measurements are still ongoing in the industry, including the ISO. The experience amongst IACS Members is also developing. MEPC 82 (October 2024) further agreed to an experience-building phase for URN from shipping until the end of 2026.

It was therefore recognized that a Recommendation would be a more appropriate instrument given the industry developments and the increasing experience amongst IACS Members, as this instrument could be more timely adapted to changes than a UR.

The IACS Recommendation also makes reference to a draft international specification (ISO/DIS 17208-3) and should therefore be revisited upon finalization of the ISO standard.

The Safety Panel recognised that industry and technology developments would take place in incremental steps, that a UR therefore may be premature, and that the new Recommendation was one of those steps that should be published to visualize the IACS engagement and encourage further industry developments. It was therefore suggested that the new Recommendation should be submitted to SDC 11 as an INF paper to support the IMO experience building phase.

6. Attachments if any

None.

Recommendation No.182 "Onshore Power Supply"

Summary

In this Recommendation, the provisions for OPS (Onshore Power Supply) are provided to facilitate uniform and global implementation of the IMO interim guidelines, international standards and members Rules/Guides, covering constructional as well as operational aspects.

Part A. Revision History

Version no.	Approval date	Implementation date when applicable
New (Dec 2024)	19 December 2024	-

- **New (Dec 2024)**

1 Origin for Change:

- Other (In pursuit of GPG instruction via 19126_IGc – Consider the need of UR on "cold ironing amongst the Members – C79 FUA 15)

2 Main Reason for Change:

As the IMO interim guidelines are limited to operation aspects, it was deemed necessary to develop a Recommendation comprising both construction and operational requirements.

3 Surveyability review of UR and Auditability review of PR

Not applicable.

4 Human Element issues assessment

Not applicable.

5 List of non-IACS Member classification societies contributing or participating in IACS Working Group:

None

6 History of Decisions Made:

After deliberation on the GPG instruction via 19126_IGc dated 23 August 2019, MP agreed to develop a REC on cold ironing when the IMO interim guidelines are approved.

By the time the IMO interim guidelines are finalized, MP prepared a draft REC based on the interim guidelines and IEC/IEEE standard and commenced discussions.

7 Other Resolutions Changes:

None

8 Any hinderance to MASS, including any other new technologies:

None

9 Dates:

Original Proposal	: 31 March 2020	(Ref: PM20910_IMa)
Panel Approval	: 03 December 2024	(Ref: PM20910_IMt)
GPG Approval	: 19 December 2024	(Ref: 19126_IGm)

Part B. Technical Background

List of Technical Background (TB) documents for Recommendation No. 182:

Annex 1. **TB for New (Dec 2024)**

See separate TB document in Annex 1.

Technical Background (TB) document for Rec 182 (New Dec 2024)

1. Scope and objectives

In this Recommendation, the provisions for OPS (Onshore Power Supply) are provided to facilitate uniform and global implementation of the IMO interim guidelines, international standards and members Rules/Guides, covering constructional as well as operational aspects.

2. Engineering background for technical basis and rationale

As the IMO interim guidelines are limited to operational dimension, it is deemed necessary to develop a comprehensive guideline both for operational and constructional aspects, taking into account the IMO interim guidelines, Members Rules & Guides and International Standards such as IEC/IEEE 80005 series.

2a. Specification of the data utilised in the development/revision of the proposed IACS Resolution, if any

N/A.

3. Source/derivation of the proposed IACS Resolution

MSC.1/Circ.1675 -Interim Guidelines on The Safe Operation of Onshore Power Supply (OPS) Service in Port for Ships Engaged on International Voyages

IEC/IEEE 80005 series

Members Rules & Guides

IACS REC - Earthing guidelines for various systems (ref.: GPG 93 FUA 14) (19024)

4. Summary of Changes intended for the revised Resolution:

None. (new publication)

5. Points of discussions or possible discussions

There was an issue whether the document should only be dedicated to HVSC or cover both HVSC and LVSC.

As expressed in Introduction of the document, it addresses general issues and specific requirements for HVSC and the requirements for LVSC will be further updated when the international standards for LVSC be published. And it is the basic principle of the document that the part not specifically indicated is universally applicable to both HVSC and LVSC and when there is specific indication such as HVSC or LVSC in the paragraph, it is only applicable to HVSC or LVSC. For the time being, it is proposed that the title of the document is maintained.

Also it was pointed out that operational procedures would not be included in main text but to be moved to Appendix for reference.

There have been very intensive discussions over the nature of the document whether it is to be a UR or a REC. After series of deliberations, it is finally decided to publish as a REC in consideration of urgent request of the Industry and then will make a necessary update reflecting the Industry feedback as well as regulatory requirements such as FuelEU and IMO guidelines, in order to set out a UR.

A member expressed concern on the shore-side installation and verification, and it was generally shared by the members that the shore-side installation is not subject to verification. As it is declared in the 1.1.2 that onshore equipment and installations are not covered by this recommendation and also considering it is converted into a REC of not mandatory nature, it is decided to not specifically add a statement on this issue.

As to the clarification request on the witness of section 5, given the result of discussion over the nature of document (converting this into REC), it is deemed appropriate to delete both the expression "to the satisfaction of the Surveyor in charge in 5.1.1 and "in the presence of a Surveyor of the Society" in 5.4.2.

For the topic of different variations of HV OPS, it is agreed to discuss as a NWI (new work item) under a separate task.

6. Attachments if any

None.

Recommendation No. 183 "Ship data quality"

Summary

During the 11th meeting of the IACS Cyber Systems Panel held in 2021, following former discussions and request from GPG, the Cyber Systems Panel agreed to form a PT for the task of developing a generic method on how to determine the data quality required for applications used on board.

Part A. Revision History

Version no.	Approval date	Implementation date when applicable
New (Dec 2024)	19 December 2024	-

- **New (Dec 2024)**

1 Origin of Change:

Not applicable.

2 Main Reason for Change:

Not applicable.

3 Surveyability review of UR and Auditability review of PR

Not applicable.

4 List of non-IACS Member classification societies contributing or participating in IACS Working Group:

Not applicable.

5 History of Decisions Made:

At the 11th IACS Cyber System Panel meeting held from 23rd to 24th March 2021, CCS proposed a new work item on data quality. After discussion, the panel agreed to set up a new project team to work on this topic.

The objectives for this PT have been defined as follows:

To analyze well-known standards, discuss the principles of data quality management and describe a method as an example to determine the quality of data generated or received onboard.

6 Other Resolutions Changes:

Not applicable.

7 Any hinderance to MASS, including any other new technologies:

None.

8 Dates:

Original Proposal	: March 2022	(Made by: Cyber System Panel)
Panel Approval	: 3 December 2024	(Ref: PC21005_)
GPG Approval	: 19 December 2024	(Ref: 21198_IGi)

Part B. Technical Background

List of Technical Background (TB) documents for Rec.183:

Annex 1. **TB for New (December 2024)**

See separate TB document in Annex 1.

Technical Background (TB) document for Rec.183 (New Dec 2024)

1. Scope and objectives

The aim of this document is to develop a recommendation for a generic method on how to determine the data quality required for applications used on board. It is intended to introduce information on existing industry standards that each organization may follow based on their system specific scope and preferred applications, rather than specifying a single method to deal with data quality.

This document analyzes the applicable standards, discusses and indicate a method as an example to determine the quality of data, generated onboard vessels or received from other sources, used for functions such as performance optimization, condition-based maintenance, system diagnostics, fault prediction, telemetry, remote monitoring, and others. It does not focus on specific applications.

2. Engineering background for technical basis and rationale

Digitalization is increasingly occurring in Maritime transport. More and more data-based control system and applications are being used onboard ships. High-quality data is helpful for managers to make optimal decisions efficiently, while low-quality data will greatly affect decision-makers' judgment, resulting in inefficient resource allocation and utilization, and possibly may lead to affect safety onboard.

Data quality is the degree to which data meets the objective, which isn't uniformly specified but vary depending on the purpose of each organization. Accordingly, each organization is expected to consider what they need and find a suitable way to assure necessary data quality.

The level of data quality will influence interoperability, decision appropriateness, confirmation and correction costs, employee satisfaction, customer satisfaction, organization reputation, and other aspects. In essential systems, it will affect the performance, dependability and safety of the system.

It is then necessary to establish a generic method to a generic method on how to determine the data quality required for applications used on board.

2a. Specification of the data utilised in the development/revision of the proposed IACS Resolution, if any

N.A.

3. Source/derivation of the proposed IACS Resolution

The development of this resolution comes from the experience and knowledge of ISO 8000 series, ISO/IEC 25000 series, DAMA-DMBOK, and others, with the aim to produce a rec with generic method for ship data quality management.

The focus is on how to establish a data quality management process and how to conduct data quality assessments, but no specific methods have been proposed for quality management of the system.

Given that the quality management of ship data was proposed in the industry, it is necessary to raise the awareness of all relevant parties on data quality management at this stage, and encourage them to establish data quality management processes and methods in accordance with the business objectives of ship applications. If we accumulate certain experience in the future, data quality technical indicators can be established for specific application systems.

Taking into account the current situation of ship data quality management, Chapter 4 of the resolution introduces the existing well-known standards for data quality. In the ISO 8000 series, ISO/IEC 25000 series, DAMA-DMBOK and other materials, there are mature framework for data quality management processes. Therefore, when formulating the ship data quality management process, reference was made to their framework, as well as how to choose measurement dimensions. Appendix 4 provides a reference example on how to do data quality management for ship data quality management

This resolution has been designed to be open to future developments, to meet possible future evolution and improvements and continuously provide more and more appropriate answers to industry expectations e.g. on systems connectivity, digitalization and smart shipping, anticipating the needs of maritime autonomous surface ships (MASS).

4. Summary of Changes intended for the revised Resolution:

N.A.

5. Points of discussions or possible discussions

N.A.

Assumptions

Considering the initial establishment, we briefly introduced well-known standards. The ISO 8000 series, ISO/IEC 25000 series, and DAMA-DMBOK are of great reference value to the resolution. The ISO 8000 series introduces data quality management based on data, the ISO/IEC 25000 series introduces data quality management based on software systems, and DAMA-DMBOK integrates data quality into the entire data management framework, introducing data quality management.

Data quality management method

In the process of developing methods for ship data quality management, existing standards were referenced and the current development status of the ship industry was considered. This process may cover the following:

- identifying the value and risks associated with data quality in the organization;
- developing data quality management processes with respect to the supported specific use cases includes the performance, dependability and safety etc.;
- measuring and assessing current data quality;
- improving data quality management, balancing cost and effectiveness;
- continuing a cycle of measuring, assessing and improving the processes of data quality management.

Data quality management runs throughout the data lifecycle, and the cycle of measuring, assessing and improving will continue in different stages.

In the entire lifecycle of ship data, there are multiple stakeholders involved, and each stakeholder has a part in the quality of ship data as a whole, therefore this recommendation provides a brief responsibility description in the Appendix 1, which is not comprehensive but as a reference.

Data quality management is emphasized, outline of the method is given below, and example of its details is given in Appendix 4.

(1) Select dimensions to fit in system specific goals as follows:

- Identify data items critical to quality objectives and assess data quality
- Select dimensions from section 5.2 or Appendix 4 and consider their weighting/how much each dimension contributes
- Specify thresholds for the assessment

(2) Verify the data quality based on the above

(3) Review the assessment results periodically

(4) Take corrective actions.

How to select dimensions

The data quality to support system specific processes in a timely and cost-effective manner requires both an understanding of the characteristics of the data that determine its quality, and an ability to measure, manage and report on data quality.

Dimensions of length, width and height are used to measure the size of a physical object. If the object is a cylinder, radius can be useful. When qualifying the data quality, it is important to utilize appropriate dimensions.

A lot of dimensions have been proposed in various fields but there are no unified set of dimensions. Accordingly, each organization should produce their own metrics systematically, suitable to their system specific goals.

6. Attachments if any

N.A.

Recommendation No.184

“Guidelines on safety standards for work”

Summary

This Recommendation is developed to enhance the control measures for OSH risks faced by surveyors and for establishing a consistent approach with respect to occupational health and safety matters. This recommendation provides the guidelines on safety standards and the precautions to be taken **(DO’s)** and unsafe acts/conditions to be avoided **(DON’T’s)** for performing surveys, inspections, audits etc. in a safe and efficient manner.

Part A. Revision History

Version no.	Approval date	Implementation date when applicable
New (Jan 2025)	7 January 2025	-

- **New (Jan 2025)**

1 Origin for Change:

EG/SoS has been tasked by GPG (S/N: 21070b) to:

1. Identify and finalise the hazards/OSH risks faced by class surveyors.
2. Develop a draft set of safety guidelines/Critical safe behaviours guidelines for each risk based on following:
 - a) Members own internal procedures/rules
 - b) Experience/expertise of Members
 - c) IACS joint Safety Statement on Safety of Surveyors
 - d) Relevant IACS PRs, URs, UIs & Recommendations related to safety (Ex: PR-37, Rec 39, 72, 78,134,136,140,141 etc.)
 - e) Relevant requirements/guidelines of IMO, ISO/IEC standards, other international standards and best practices within the industry (Ex: ICS, OCIMF, ISGOTT etc.)

2 Main Reason for Change:

Not applicable.

3 List of non-IACS Member Classification Societies contributing through the TC Forum and/or participating in IACS Working Group:

Not applicable.

4 History of Decisions Made

The EG/SOS has developed the "Guidelines on safety standards for work" by correspondence within the EG members by considering Members own internal procedures/rules, experience/expertise of Members, relevant requirements/guidelines of IMO, ISO/IEC standards, other international standards and best practices within the industry.

The new guidelines developed by EG/SOS are agreed by all members unanimously.

5 Other Resolutions Changes

None.

6 Dates:

Original Proposal	: 15 July 2024	(Ref: 21070bIGd)
Panel Approval	: 06 December 2024	(Ref: 21070bESc)
GPG Approval	: 07 January 2025	(Ref: 21070bIGg)

Part B. Technical Background

List of Technical Background (TB) documents for Rec.184:

Note: *There is no separate Technical Background (TB) documents for New (Jan 2025).*