

E10 Test Specification for Type Approval

(1991)
 (Rev.1
 1993)
 (Rev.2
 1997)
 (Rev. 2.1
 July 1999)
 (Rev.3
 May 2001)
 (Corr.1
 July 2003)
 (Rev.4
 May 2004)
 (Rev.5
 Dec 2006)
 (Rev.6
 Oct 2014)
 (Rev.7
 Oct 2018)
 (Rev.8
 Feb 2021)
 (Corr.1
 Jan 2022)
 (Rev.9
 Aug 2023)

E10.1 General

This Test Specification is applicable, but not confined, to electrical, electronic and programmable equipment intended for control, monitoring, alarm and protection systems for use in ships.

E10.2 Testing

These tests are to demonstrate the ability of the equipment to function as intended under the specified testing conditions.

The extent of the testing (i.e. the selection and sequence of carrying out tests and number of pieces to be tested) is to be determined upon examination and evaluation of the equipment or component subject to testing giving due regard to its intended usage.

Equipment is to be tested in its normal position if otherwise not specified in the test specification.

Note:

1. Rev.5 of this UR is to be uniformly implemented by IACS Societies from 1 January 2008.
2. Rev.6 of this UR is to be uniformly implemented by IACS Societies from 1 January 2016.
3. Rev.7 of this UR is to be uniformly implemented by IACS Societies for equipment for which the date of application for type approval certification is dated on or after 1 January 2020.
4. Equipment intended to be installed on ships contracted for construction on or after 1 January 2022 is to comply with Rev.7 of this UR.
5. The “contracted for construction” date means the date on which the contract to build the vessel is signed between the prospective owner and the shipbuilder. For further details regarding the date of “contract for construction”, refer to IACS Procedural Requirement (PR) No. 29.
6. The “date of application for type approval” is the date of documents accepted by the Classification Society as request for type approval certification of a new equipment type or of an equipment type that has undergone substantive modifications in respect of the one previously type approved, or for renewal of an expired type approval certificate.
7. Rev.8 of this UR is to be uniformly implemented by IACS Societies for equipment for which the date of application for type approval certification is dated on or after 1 July 2022.
8. Rev.9 of this UR is to be uniformly implemented by IACS Societies for equipment for which the date of application for type approval certification is dated on or after 1 July 2024.

E10

(cont)

Relevant tests are as listed in the Table.

Note:

- a) * These test requirements are harmonised with IEC 60092-504:2016 “Electrical Installations in Ships - Part 504: Special features - Control and Instrumentation” and IEC 60533:2015 “Electrical and electronic installations in ships – electromagnetic compatibility”. Electrical and electronic equipment on board ships, required neither by classification rules nor by International Conventions, liable to cause electromagnetic disturbance shall be of type which fulfil the test requirements of test specification items 19 and 20.
- b) As used in this document, and in contrast to a complete performance test, a functional test is a simplified test sufficient to verify that the equipment under test (EUT) has not suffered any deterioration caused by the individual environmental tests.

Type testing condition for equipment covered by E10.1

NO.	TEST	PROCEDURE ACC. TO:*	TEST PARAMETERS	OTHER INFORMATION
<p>* indicates the testing procedure which is normally to be applied. However, equivalent testing procedure may be accepted by the individual Society provided that the Unified Requirements stated in the other columns are fulfilled. Later versions (including revisions) of the international standards specified in this UR are acceptable for use, provided the Society determines them to be equivalent to the technical specifications of this UR.</p>				
1.	Visual inspection	-	-	- conformance to drawings, design data
2.	Performance test	<p>Manufacturer performance test programme based upon specification and relevant Rule requirements. When the EUT is required to comply with an international performance standard, e.g. protection relays, verification of requirements in the standard are to be part of the performance testing required in this initial test and subsequent performance tests after environmental testing where required in the UR.</p>	<ul style="list-style-type: none"> - standard atmosphere conditions - temperature: 25°C ± 10°C - relative humidity: 60% ± 30% - air pressure: 96 KPa ± 10KPa 	<ul style="list-style-type: none"> - confirmation that operation is in accordance with the requirements specified for particular system or equipment; - checking of self-monitoring features; - checking of specified protection against an access to the memory; - checking against effect of unerroneous use of control elements in the case of computer systems.

E10
(cont)

NO.	TEST	PROCEDURE ACC. TO:*	TEST PARAMETERS	OTHER INFORMATION
5.	Dry heat (see note 1)	IEC 60068-2-2:2007 Test Bb for non-heat dissipating equipment	Temperature: 55° ± 2°C Duration: 16 hours or Temperature: 70°C ± 2°C Duration: 16 hours	- equipment operating during conditioning and testing; - functional test (b) during the last hour at the test temperature. - for equipment specified for increased temperature the dry heat test is to be conducted at the agreed test temperature and duration.
		IEC 60068-2-2:2007 Test Be for heat dissipating equipment	Temperature: 55° ± 2°C Duration: 16 hours or Temperature: 70°C ± 2°C Duration: 16 hours	- equipment operating during conditioning and testing with cooling system on if provided; - functional test (b) during the last hour at the test temperature. - for equipment specified for increased temperature the dry heat test is to be conducted at the agreed test temperature and duration.
6.	Damp heat	IEC 60068-2-30:2005 test D _b	Temperature: 55°C Humidity: 95% Duration: 2 cycles 2 x (12 +12 hours)	- measurement of insulation resistance before test; - the test shall start with 25°C ± 3°C and at least 95% humidity; - equipment operating during the complete first cycle and switched off during second cycle except for functional test; - functional test during the first 2 hours of the first cycle at the test temperature and during the last 2 hours of the second cycle at the test temperature; Duration of the second cycle can be extended due to more convenient handling of the functional test. - recovery at standard atmosphere conditions; - insulation resistance measurements and performance test.
7.	Vibration	IEC 60068-2-6:2007 Test F _c	2 ⁺³ Hz to 13.2 Hz – amplitude ±1mm	- duration in case of no resonance condition 90

NO.	TEST	PROCEDURE ACC. TO:*	TEST PARAMETERS	OTHER INFORMATION																
				<p>The test in each direction is to be carried out for not less than 15 minutes.</p> <p>On ships for the carriage of liquified gases and chemicals, the emergency power supply is to remain operational with the ship flooded up to a maximum final athwart ship inclination of 30°.</p> <p>Note: These inclination tests are normally not required for equipment with no moving parts.</p>																
9.	Insulation resistance		<table border="1"> <thead> <tr> <th data-bbox="607 552 824 635">Rated supply voltage Un (V)</th> <th data-bbox="824 552 1041 635">Test voltage (D.C. voltage) (V)</th> <th colspan="2" data-bbox="1041 552 1487 580">Min. insulation resistance</th> </tr> <tr> <td></td> <td></td> <th data-bbox="1041 580 1263 635">before test M ohms</th> <th data-bbox="1263 580 1487 635">after test M ohms</th> </tr> </thead> <tbody> <tr> <td data-bbox="607 635 824 695">Un ≤ 65</td> <td data-bbox="824 635 1041 695">2 x Un min. 24V</td> <td data-bbox="1041 635 1263 695">10</td> <td data-bbox="1263 635 1487 695">1,0</td> </tr> <tr> <td data-bbox="607 695 824 724">Un > 65</td> <td data-bbox="824 695 1041 724">500</td> <td data-bbox="1041 695 1263 724">100</td> <td data-bbox="1263 695 1487 724">10</td> </tr> </tbody> </table>	Rated supply voltage Un (V)	Test voltage (D.C. voltage) (V)	Min. insulation resistance				before test M ohms	after test M ohms	Un ≤ 65	2 x Un min. 24V	10	1,0	Un > 65	500	100	10	<p>- For high voltage equipment, reference is made to UR E11.</p> <p>- insulation resistance test is to be carried out before and after: damp heat test, cold test, salt mist test and high voltage test;</p> <p>- between all phases and earth; and where appropriate, between the phases.</p> <p>Note: Certain components e.g. for EMC protection may be required to be disconnected for this test.</p>
Rated supply voltage Un (V)	Test voltage (D.C. voltage) (V)	Min. insulation resistance																		
		before test M ohms	after test M ohms																	
Un ≤ 65	2 x Un min. 24V	10	1,0																	
Un > 65	500	100	10																	
10.	High voltage		<table border="1"> <thead> <tr> <th data-bbox="607 887 1041 970">Rated voltage Un (V)</th> <th data-bbox="1041 887 1487 970">Test voltage (A.C. voltage 50 or 60Hz) (V)</th> </tr> </thead> <tbody> <tr> <td data-bbox="607 970 1041 999">Up to 65</td> <td data-bbox="1041 970 1487 999">2 x Un + 500</td> </tr> <tr> <td data-bbox="607 999 1041 1027">66 to 250</td> <td data-bbox="1041 999 1487 1027">1500</td> </tr> <tr> <td data-bbox="607 1027 1041 1056">251 to 500</td> <td data-bbox="1041 1027 1487 1056">2000</td> </tr> <tr> <td data-bbox="607 1056 1041 1085">501 to 690</td> <td data-bbox="1041 1056 1487 1085">2500</td> </tr> </tbody> </table>	Rated voltage Un (V)	Test voltage (A.C. voltage 50 or 60Hz) (V)	Up to 65	2 x Un + 500	66 to 250	1500	251 to 500	2000	501 to 690	2500	<p>- For high voltage equipment, reference is made to UR E11.</p> <p>- separate circuits are to be tested against each other and all circuits connected with each other tested against earth;</p> <p>- printed circuits with electronic components may be removed during the test;</p> <p>- period of application of the test voltage: 1 minute</p>						
Rated voltage Un (V)	Test voltage (A.C. voltage 50 or 60Hz) (V)																			
Up to 65	2 x Un + 500																			
66 to 250	1500																			
251 to 500	2000																			
501 to 690	2500																			
11.	Cold	IEC 60068-2-1:2007	<p>Temperature: +5°C ± 3°C Duration: 2 hours or Temperature: -25°C ± 3°C Duration: 2 hours (see note 2)</p>	<p>- initial measurement of insulation resistance;</p> <p>- equipment not operating during conditioning and testing except for functional test;</p> <p>- functional test during the last hour at the test temperature;</p> <p>- insulation resistance measurement and the</p>																

NO.	TEST	PROCEDURE ACC. TO:*	TEST PARAMETERS	OTHER INFORMATION
				functional test after recovery
12.	Salt mist	IEC 60068-2-52:2017 Test Kb	Four spraying periods with a storage of 7 days after each.	<ul style="list-style-type: none"> - initial measurement of insulation resistance and initial functional test; - equipment not operating during conditioning; - functional test on the 7th day of each storage period; - insulation resistance measurement and performance test 4 to 6h after recovery. (see Note 3) - on completion of exposure, the equipment shall be examined to verify that deterioration or corrosion (if any) is superficial in nature.
13.	Electrostatic discharge	IEC 61000-4-2:2008	Contact discharge: 6kV Air discharge: 2kV, 4kV, 8kV Interval between single discharges: 1 sec. No. of pulses: 10 per polarity According to test level 3.	<ul style="list-style-type: none"> - to simulate electrostatic discharge as may occur when persons touch the appliance; - the test is to be confined to the points and surfaces that can normally be reached by the operator; - Performance Criterion B (See Note 4).
14.	Electromagnetic field	IEC 61000-4-3:2020 or IEC 61000-4-3:2006+AMD1:2007+AMD2:2010	Frequency range: 80 MHz to 6 GHz Modulation**: 80% AM at 1000Hz Field strength: 10V/m Frequency sweep rate: $\leq 1.5 \times 10^{-3}$ decades/s (or 1%/3 sec) According to test level 3.	<ul style="list-style-type: none"> - to simulate electromagnetic fields radiated by different transmitters; - the test is to be confined to the appliances exposed to direct radiation by transmitters at their place of installation. - Performance criterion A (See Note 5) **If for tests of equipment an input signal with a modulation frequency of 1000 Hz is necessary a modulation frequency of 400 Hz may be chosen. - If an equipment is intended to receive radio signals for the purpose of radio communication (e.g. wifi router, remote radio controller), then the immunity limits at its communication frequency do not apply, subject to the

E10
(cont)

NO.	TEST	PROCEDURE ACC. TO:*	TEST PARAMETERS	OTHER INFORMATION
				provisions "Specific requirements for wireless data links" in UR E22.
15.	Conducted low Frequency		AC: Frequency range: rated frequency to 200th harmonic; Test voltage (rms): 10% of supply to 15th harmonic reducing to 1% at 100th harmonic and maintain this level to the 200th harmonic, min 3 V r.m.s, max 2 W. DC: Frequency range: 50 Hz - 10 kHz; Test voltage (rms): 10% of supply max. 2 W	<ul style="list-style-type: none"> - to stimulate distortions in the power supply system generated for instance, by electronic consumers and coupled in as harmonics; - performance criterion A (see Note 5). - See figure - "Test set-up" - for keeping max. 2W, the voltage of the test signal may be lower.
16.	Conducted Radio Frequency	IEC 61000-4-6:2013	AC, DC, I/O ports and signal/control lines: Frequency range: 150 kHz - 80 MHz Amplitude: 3 V rms (See Note 6) Modulation ***: 80% AM at 1000 Hz Frequency sweep range: $\leq 1.5 \times 10^{-3}$ decades/s (or 1%/3sec.) According to test level 2.	<ul style="list-style-type: none"> - Equipment design and the choice of materials is to stimulate electromagnetic fields coupled as high frequency into the test specimen via the connecting lines. - performance criterion A (see Note 5). *** If for tests of equipment an input signal with a modulation frequency of 1000 Hz is necessary a modulation frequency of 400 Hz may be chosen.
17.	Electrical Fast Transients / Burst	IEC 61000-4-4:2012	Single pulse rise time: 5 ns (between 10% and 90% value) Single pulse width: 50 ns (50% value) Amplitude (peak): 2kV line on power supply port/earth; 1kV on I/O data control and communication ports (coupling clamp) Pulse period: 300 ms; Burst duration: 15 ms;	<ul style="list-style-type: none"> - arcs generated when actuating electrical contacts; - interface effect occurring on the power supply, as well as at the external wiring of the test specimen; - performance criterion B (see Note 4).

NO.	TEST	PROCEDURE ACC. TO:*	TEST PARAMETERS	OTHER INFORMATION																				
			Duration/polarity: 5 min According to test level 3.																					
18.	Surge	IEC 61000-4-5:2017	Test applicable to AC and DC power ports Open-circuit voltage: Pulse rise time: 1.2 μ s (front time) Pulse width: 50 μ s (time to half value) Amplitude (peak): 1kV line/earth; 0.5kV line/line Short-circuit current: Pulse rise time: 8 μ s (front time) Pulse width: 20 μ s (time to half value) Repetition rate: \geq 1 pulse/min No of pulses: 5 per polarity Application: continuous According to test level 2.	<ul style="list-style-type: none"> - interference generated for instance, by switching "ON" or "OFF" high power inductive consumers; - test procedure in accordance with figure 10 of the standard for equipment where power and signal lines are identical; - performance criterion B (see Note 4). 																				
19.	Radiated Emission	CISPR 16-2-3:2016 IEC 60945:2002 for 156-165 MHz	Limits below 1000 MHz For equipment installed in the bridge and deck zone. <table border="1" data-bbox="1034 916 1482 1085"> <thead> <tr> <th>Frequency range:</th> <th>Quasi peak limits:</th> </tr> </thead> <tbody> <tr> <td>0.15 - 0.3 MHz</td> <td>80 - 52 dBμV/m</td> </tr> <tr> <td>0.3 - 30 MHz</td> <td>52 - 34 dBμV/m</td> </tr> <tr> <td>30 - 1000 MHz</td> <td>54 dBμV/m</td> </tr> <tr> <td>except for: 156 -165 MHz</td> <td>24 dBμV/m</td> </tr> </tbody> </table> For equipment installed in the general power distribution zone. <table border="1" data-bbox="1034 1197 1482 1337"> <thead> <tr> <th>Frequency range:</th> <th>Quasi peak limits:</th> </tr> </thead> <tbody> <tr> <td>0.15 - 30 MHz</td> <td>80 - 50 dBμV/m</td> </tr> <tr> <td>30 - 100 MHz</td> <td>60 - 54 dBμV/m</td> </tr> <tr> <td>100 - 1000 MHz</td> <td>54 dBμV/m</td> </tr> <tr> <td>except for:</td> <td></td> </tr> </tbody> </table>	Frequency range:	Quasi peak limits:	0.15 - 0.3 MHz	80 - 52 dB μ V/m	0.3 - 30 MHz	52 - 34 dB μ V/m	30 - 1000 MHz	54 dB μ V/m	except for: 156 -165 MHz	24 dB μ V/m	Frequency range:	Quasi peak limits:	0.15 - 30 MHz	80 - 50 dB μ V/m	30 - 100 MHz	60 - 54 dB μ V/m	100 - 1000 MHz	54 dB μ V/m	except for:		<ul style="list-style-type: none"> - procedure in accordance with the standard but distance 3 m between equipment and antenna - for the frequency band 156 MHz to 165 MHz the measurement shall be repeated with a receiver bandwidth of 9 kHz (as per IEC 60945:2002). - alternatively the radiation limit at a distance of 3 m from the enclosure port over the frequency 156 MHz to 165 MHz shall be 30 dB micro-V/m Peak (as per IEC 60945:2002).
Frequency range:	Quasi peak limits:																							
0.15 - 0.3 MHz	80 - 52 dB μ V/m																							
0.3 - 30 MHz	52 - 34 dB μ V/m																							
30 - 1000 MHz	54 dB μ V/m																							
except for: 156 -165 MHz	24 dB μ V/m																							
Frequency range:	Quasi peak limits:																							
0.15 - 30 MHz	80 - 50 dB μ V/m																							
30 - 100 MHz	60 - 54 dB μ V/m																							
100 - 1000 MHz	54 dB μ V/m																							
except for:																								

E10
(cont)

NO.	TEST	PROCEDURE ACC. TO:*	TEST PARAMETERS	OTHER INFORMATION																
			<table border="1" data-bbox="1037 188 1482 220"> <tr> <td>156 -165 MHz</td> <td>24 dBμV/m</td> </tr> </table> <p>Limits above 1000 MHz</p> <table border="1" data-bbox="1037 300 1482 363"> <tr> <td>Frequency range:</td> <td>Average limit:</td> </tr> <tr> <td>1000 - 6000 MHz</td> <td>54 dBμV/m</td> </tr> </table>	156 -165 MHz	24 dB μ V/m	Frequency range:	Average limit:	1000 - 6000 MHz	54 dB μ V/m	<p>- procedure in accordance with the standard (distance 3 m between equipment and antenna)</p> <p>-Equipment intended to transmit radio signals for the purpose of radio communication (e.g. wifi router, remote radio controller) may be exempted from limit, within its communication frequency range, subject to the provisions “ Specific requirements for wireless data links” in UR E22.</p>										
156 -165 MHz	24 dB μ V/m																			
Frequency range:	Average limit:																			
1000 - 6000 MHz	54 dB μ V/m																			
20.	Conducted Emission	CISPR 16-2-1:2017	<p>Test applicable to AC and DC power ports</p> <p>For equipment installed in the bridge and deck zone.</p> <table border="1" data-bbox="1037 722 1482 834"> <tr> <td>Frequency range:</td> <td>Limits:</td> </tr> <tr> <td>10 - 150 kHz</td> <td>96 - 50 dBμV</td> </tr> <tr> <td>150 - 350 kHz</td> <td>60 - 50 dBμV</td> </tr> <tr> <td>350 kHz - 30 MHz</td> <td>50 dBμV</td> </tr> </table> <p>For equipment installed in the general power distribution zone.</p> <table border="1" data-bbox="1037 1007 1482 1118"> <tr> <td>Frequency range:</td> <td>Limits:</td> </tr> <tr> <td>10 - 150 kHz</td> <td>120 - 69 dBμV</td> </tr> <tr> <td>150 - 500 kHz</td> <td>79 dBμV</td> </tr> <tr> <td>0.5 - 30 MHz</td> <td>73 dBμV</td> </tr> </table>	Frequency range:	Limits:	10 - 150 kHz	96 - 50 dB μ V	150 - 350 kHz	60 - 50 dB μ V	350 kHz - 30 MHz	50 dB μ V	Frequency range:	Limits:	10 - 150 kHz	120 - 69 dB μ V	150 - 500 kHz	79 dB μ V	0.5 - 30 MHz	73 dB μ V	
Frequency range:	Limits:																			
10 - 150 kHz	96 - 50 dB μ V																			
150 - 350 kHz	60 - 50 dB μ V																			
350 kHz - 30 MHz	50 dB μ V																			
Frequency range:	Limits:																			
10 - 150 kHz	120 - 69 dB μ V																			
150 - 500 kHz	79 dB μ V																			
0.5 - 30 MHz	73 dB μ V																			
21.	Flame retardant	IEC 60092-101:2018 or	<p>Flame application: 5 times 15 s each. Interval between each application: 15s or 1 time 30s.</p> <p>Test criteria based upon application.</p>	<p>- the burnt out or damaged part of the specimen by not more than 60 mm long.</p> <p>- no flame, no incandescence or</p> <p>- in the event of a flame or incandescence being present, it shall extinguish itself within 30 s of the removal of the needle flame</p>																

E10
(cont)

NO.	TEST	PROCEDURE ACC. TO:*	TEST PARAMETERS	OTHER INFORMATION
		IEC 60695-11-5:2016	The test is performed with the EUT or housing of the EUT applying needle-flame test method.	without full combustion of the test specimen. - any dripping material shall extinguish itself in such a way as not to ignite a wrapping tissue. The drip height is 200 mm ± 5 mm.

E10 (cont)

Notes:

1. Dry heat at 70 °C is to be carried out to automation, control and instrumentation equipment subject to high degree of heat, for example mounted in consoles, housings, etc. together with other heat dissipating power equipment.
2. For equipment installed in non-weather protected locations or cold locations test is to be carried out at -25°C.
3. Salt mist test is to be carried out for equipment installed in weather exposed areas.
4. Performance Criterion B: (For transient phenomena): The EUT shall continue to operate as intended after the tests. No degradation of performance or loss of function is allowed as defined in the technical specification published by the manufacturer. During the test, degradation or loss of function or performance which is self recoverable is however allowed but no change of actual operating state or stored data is allowed.
5. Performance Criterion A: (For continuous phenomena): The Equipment Under Test shall continue to operate as intended during and after the test. No degradation of performance or loss of function is allowed as defined in relevant equipment standard and the technical specification published by the manufacturer.
6. For equipment installed on the bridge and deck zone, the test levels shall be increased to 10V rms for spot frequencies in accordance with IEC 60945:2002 at 2, 3, 4, 6.2, 8.2, 12.6, 16.5, 18.8, 22, 25 MHz.

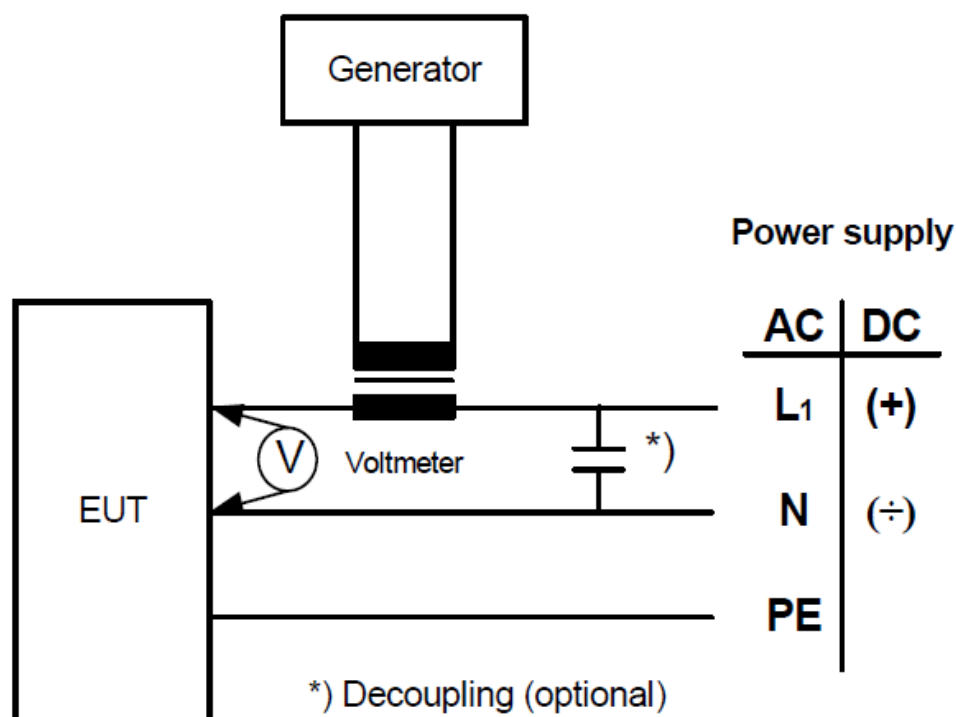

Figure - Test Set-up – Conducted Low Frequency Test

End of
Document